



**MAX SPARE**















**L I M I T E D**

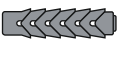













QUALITY. PRECISION. SPEED.



**STOCKLIST 2026**

VERSION 21

MAX TYPE	PRODUCT NAME	SEAL PROFILE	MATL	PAGE NO.
<b>HYDRAULIC PISTON SEALS</b>				
P52	COMPACT SEAL		PU NBR POM	01
P45	GLYD RING		NBR BRONZE PTFE	04
E07	U SEAL		PU	06
<b>HYDRAULIC ROD SEALS</b>				
S15	STEP SEAL		BRONZE PTFE NBR	12
S19	U SEAL		PU	14
S59	CHEVRON PACK		NBR / FABRIC	17
S60	CHEVRON PACK		NBR / FABRIC	17
<b>HYDRAULIC WIPER SEALS</b>				
W11	WIPER SEAL		NBR	20
W12	WIPER SEAL		NBR	22
W14	WIPER SEAL		NBR STEEL	24
W10	WIPER SEAL		NBR	25
W13	WIPER SEAL		PU	28
W16	WIPER SEAL		PU STEEL	29
W38	SCRAPER RING		BRONZE PTFE NBR	30

MAX TYPE	PRODUCT NAME	SEAL PROFILE	MATL	PAGE NO.
GS	WEAR RINGS		BFT/PRW	31
<b>PNEUMATIC SEALS</b>				
P27	HECKER SEAL		NBR	32
W07	WIPER SEAL		PU	33
S09	CUSHION SEAL		PU	34
<b>ROTARY SHAFT SEALS</b>				
R01 R15			NBR	35
R02 R17			FKM	70
R56	TEFLON SEAL		PTFE NBR STEEL	78
R31	FABRIC SEAL		NBR FABRIC SPRING	79
RB7	END CAP SEAL		NBR	80
V01	V RING		NBR	81
V02	V RING		NBR	82
V03	V RING		NBR	83
<b>O-RINGS</b>				
OR	O-RING		NBR	84
			FKM	104
ORS KIT			NBR / FKM	114
CD	O-RING CORD		NBR FKM SILICON PU	117

# INDEX

MAX TYPE	PRODUCT NAME	SEAL PROFILE	MATL	PAGE NO.
----------	--------------	--------------	------	----------

## QUAD-RINGS 118

QR	QUAD RING		NBR
----	-----------	---	-----

## BONDED SEALS 121

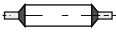
B01	BONDED SEAL		NBR FKM
-----	-------------	---	------------

## RIVAL Y RING 122

A05	RIVAL Y RING		NBR
-----	--------------	---	-----

## EARTHMOVING SEAL KITS 123



## NIRLON V-BELTS 124

-	-		
---	---	---	--

## PULLEYS 153

### V-LOCK PULLEYS



## BELT TOOLS 156

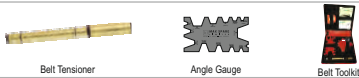

Belt Tensioner

Angle Gauge

Belt Toolkit

## SPIDERS 157

N Series, M Series, P Series,  
T Series, K Series, H Series,  
NW Series, TY Series



## COUPLINGS 161

CN, CP, CK  
& CTY



## MOUNTINGS 164

VM & LM SERIES



MAX TYPE	PRODUCT NAME	SEAL PROFILE	MATL	PAGE NO.
----------	--------------	--------------	------	----------

## TOOLS 166



Depth Caliper, Piston Seal  
Constrictor, 'O' Ring Hook,  
Seal Twistor

## LUBRICANTS 167



Max Multipurpose Grease

Max-O-Lube

Max 40 Multifunctional Fluid

## TOOLS 168



IR Thermometer

Contact Tachometer

Seal Maintenance Tool Box

Circometer

## FELT SHEET 170

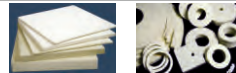

## GASKET 171



## BRAIDED PACKING 172

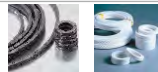

## MECHANICAL SEALS 173



## DUO CONE SEAL 176



## STORAGE OF SEALS 177

**Note :** Max Spare is continuously adding new products & sizes in it's standard stock range. Hence do not hesitate to contact sales team for your requirements.

## SEALING MATERIAL 178

## DOUBLE ACTING COMPACT SEAL

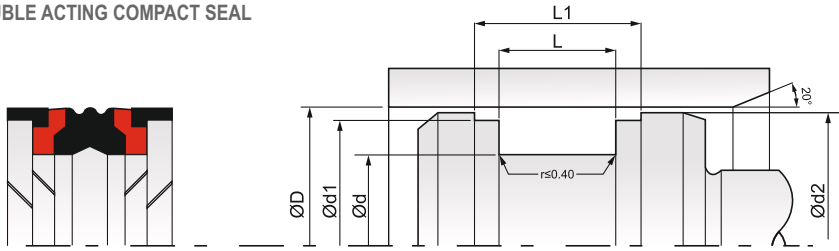

### MATERIAL :

- A) SEAL RING : NBR75/80 shore 'A'.
- B) BACK UP RING : Thermoplastic Elastomer
- C) BEARING RINGS : Acetal (Optional Material : Polyamide)

### MAX OPERATING CONDITIONS :

Temp.	-30°C to +100 °C	Pressure	400 BAR	Speed	0.5 mtr./sec.
-------	------------------	----------	---------	-------	---------------

Max Spare Part No.	D (H9)	d (h9)	d1 (h9)	L (+0.2)	L1 (+0.2)	d2 (h11)
P52 0110901	20.00	11.00	17.00	13.50	17.70	19.00
P52 0150901	25.00	15.00	21.00	12.00	20.00	23.00
P52 0150902	25.00	15.00	21.45	16.40	29.10	23.50
P52 0170901	30.00	17.00	26.50	15.40	28.10	28.50
P52 0210901	30.00	21.00	27.00	13.50	17.70	29.00
P52 0220901	32.00	22.00	28.50	16.40	29.10	30.50
P52 0240901	32.00	24.00	29.00	10.00	18.00	31.00
P52 0250901	35.00	25.00	31.40	16.40	29.10	33.50
P52 0240902	40.00	24.00	35.40	18.40	31.10	38.50
P52 0260901	40.00	26.00	36.00	15.50	20.70	39.00
P52 0300901	40.00	30.00	35.40	16.40	29.10	38.50
P52 0300902	40.00	30.00	37.00	12.50	20.50	39.00
P52 0320901	40.00	32.00	36.00	15.50	21.90	39.40
P52 0280901	42.00	28.00	38.00	15.50	20.70	41.00
P52 0290901	45.00	29.00	40.40	18.40	31.10	43.70
P52 0350901	45.00	35.00	40.40	16.40	29.10	43.50
P52 0340901	50.00	34.00	45.40	18.40	31.10	48.50
P52 0340902	50.00	34.00	46.00	20.00	26.20	48.00
P52 0350902	50.00	35.00	46.00	20.00	30.00	48.50
P52 0380902	50.00	38.00	46.00	20.50	28.90	49.40
P52 0390901	55.00	39.00	50.36	18.40	31.10	53.50
P52 0440901	60.00	44.00	55.40	18.40	31.10	58.50
P52 0440902	60.00	44.00	56.00	20.50	26.70	59.00
P52 0480901	60.00	48.00	56.00	20.50	28.90	59.40
P52 0470901	63.00	47.00	58.40	18.40	31.10	61.50
P52 0470902	63.00	47.00	59.00	20.50	28.90	62.00
P52 0480902	63.00	48.00	59.00	20.00	30.00	61.50
P52 0510901	63.00	51.00	59.00	20.50	28.90	62.40
P52 0500901	65.00	50.00	60.40	18.40	31.10	65.00

## DOUBLE ACTING COMPACT SEAL

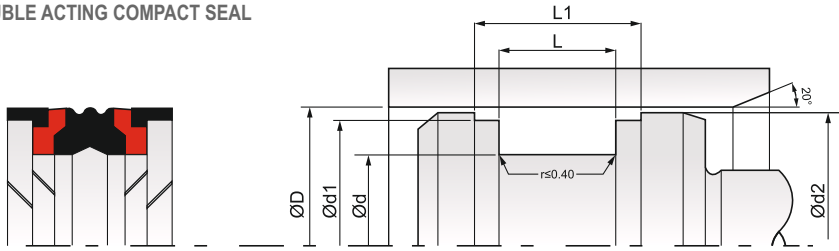

Max Spare Part No.	D (H9)	d (h9)	d1 (h9)	L (+0.2)	L1 (+0.2)	d2 (h11)
P52 0500902	70.00	50.00	64.20	22.40	35.10	68.34
P52 0540901	70.00	54.00	66.00	20.50	26.70	69.00
P52 0580901	70.00	58.00	66.00	20.50	28.90	68.50
P52 0550901	75.00	55.00	69.20	22.40	35.10	73.32
P52 0600901-A	80.00	60.00	74.15	22.40	35.10	78.34
P52 0600902	80.00	60.00	75.00	25.40	38.10	78.00
P52 0620901	80.00	62.00	76.00	22.40	29.70	79.00
P52 0650901	80.00	65.00	76.00	20.00	30.00	79.00
P52 0650902	85.00	65.00	79.15	22.40	35.10	83.34
P52 0700901	90.00	70.00	84.15	22.40	35.10	88.30
P52 0750901	95.00	75.00	89.15	22.40	35.10	93.30
P52 0750902	100.00	75.00	93.15	22.40	35.10	98.00
P52 0800901	100.00	80.00	95.00	25.40	38.10	98.00
P52 0820901	100.00	82.00	96.00	22.50	29.70	99.00
P52 0860901	100.00	86.00	96.00	22.50	32.90	98.50
P52 0800902	105.00	80.00	98.10	22.40	35.10	103.00
P52 0850901	110.00	85.00	103.10	22.40	35.10	108.00
P52 0920901	110.00	92.00	106.00	22.50	29.70	109.00
P52 0900901	115.00	90.00	108.10	22.40	35.10	113.00
P52 0950901	120.00	95.00	113.10	22.40	35.10	118.00
P52 1000901	125.00	100.00	118.10	25.40	38.10	122.96
P52 1030901	125.00	103.00	121.00	26.50	36.70	124.00
P52 1050901	125.00	105.00	120.00	25.40	38.10	123.00
P52 1080901	125.00	108.00	121.00	26.50	40.90	124.40
P52 1050902	130.00	105.00	122.60	25.40	44.40	127.50
P52 1100901	135.00	110.00	127.60	25.40	44.40	132.50
P52 1100902	135.00	110.00	128.10	25.40	38.10	133.00
P52 1150901	140.00	115.00	132.60	25.40	44.40	137.50
P52 1150903	140.00	115.00	133.00	25.40	38.10	138.00
P52 1180901	140.00	118.00	136.00	26.50	36.70	139.00
P52 1200901	145.00	120.00	137.60	25.40	44.40	142.50
P52 1200902	145.00	120.00	138.30	25.40	38.10	142.95
P52 1250901	150.00	125.00	142.60	25.40	44.40	147.50
P52 1250902	150.00	125.00	143.00	25.40	38.10	148.00
P52 1280901	150.00	128.00	146.00	26.50	36.70	149.00
P52 1300901	155.00	130.00	147.60	25.40	44.40	152.50
P52 1300903	160.00	130.00	152.60	25.40	44.40	157.50

## DOUBLE ACTING COMPACT SEAL

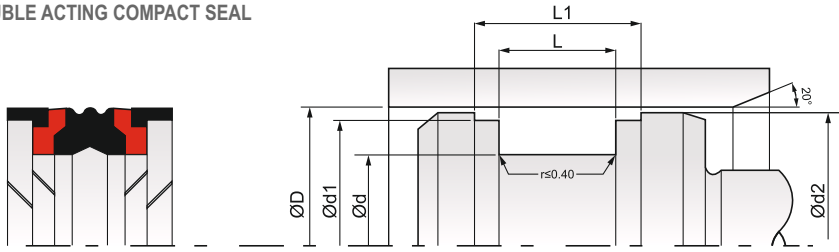

Max Spare Part No.	D (H9)	d (h9)	d1 (h9)	L (+0.2)	L1 (+0.2)	d2 (h11)
P52 1300902	160.00	130.00	153.00	25.40	38.10	158.00
P52 1350901	160.00	135.00	152.60	25.40	44.40	157.50
P52 1380901	160.00	138.00	156.00	26.50	36.70	159.00
P52 1400901	165.00	140.00	157.60	25.40	44.40	162.50
P52 1450901	170.00	145.00	161.70	25.40	50.80	167.50
P52 1500901	175.00	150.00	166.70	25.40	50.80	172.10
P52 1500903	180.00	150.00	172.95	35.40	48.10	177.87
P52 1550901	180.00	155.00	171.70	25.40	50.80	177.00
P52 1580901	180.00	158.00	176.00	26.50	36.70	179.00
P52 1600901	185.00	160.00	176.70	25.40	50.80	182.00
P52 1650901	190.00	165.00	181.70	25.40	50.80	187.00
P52 1700901	195.00	170.00	186.70	25.40	50.80	192.00
P52 1700902	200.00	170.00	193.00	35.40	48.10	198.00
P52 1750901	200.00	175.00	191.60	25.40	50.80	197.00
P52 1750902	200.00	175.00	196.00	31.50	44.70	199.00
P52 1850901	210.00	185.00	201.60	25.40	50.80	207.00
P52 1900902	220.00	190.00	212.70	35.40	48.10	217.00
P52 1950901	220.00	195.00	211.60	25.40	50.80	217.00
P52 2050901	230.00	205.00	221.60	25.40	50.80	227.00
P52 2150901	240.00	215.00	231.60	25.40	50.80	237.00
P52 2200901	250.00	220.00	242.90	35.40	48.10	247.00
P52 2250901	250.00	225.00	241.60	25.40	50.80	247.00
P52 2750901	300.00	275.00	291.60	25.40	50.80	298.00

## DOUBLE ACTING COMPACT SEAL

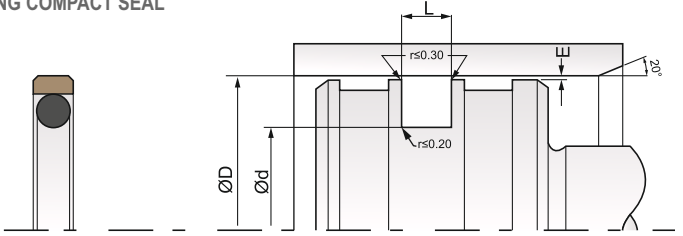

### MATERIAL :

- A) O RING : NBR 70/75 Shore 'A'.
- B) SEALING RING : Bronze filled PTFE

### MAX OPERATING CONDITIONS :

Temp.	-30°C to +100 °C	Pressure	400 BAR	Speed	10.0 mtr./sec.
-------	------------------	----------	---------	-------	----------------

Max Spare Part No.	D (H9)	d (h9)	L (+0.2)	O'Ring Part No.	Max Spare Part No.	D (H9)	d (h9)	L (+0.2)	O'Ring Part No.
P45 0090801	9.10	14.00	2.20	OR 17800874	<b>P45 0490801</b>	<b>60.00</b>	<b>49.00</b>	<b>4.20</b>	<b>OR 35304722</b>
<b>P45 0050801</b>	<b>10.00</b>	<b>5.10</b>	<b>2.20</b>	<b>OR 17800447</b>	<b>P45 0527101</b>	<b>63.00</b>	<b>52.00</b>	<b>4.20</b>	<b>OR 35305080</b>
P45 0070801	12.00	7.10	2.20	OR 17800675	<b>P45 0470804</b>	<b>63.00</b>	<b>47.50</b>	<b>6.30</b>	<b>OR 53304699</b>
P45 0090801	14.00	9.00	2.20	OR 17800873	P45 0520813	63.50	52.50	4.20	OR 35305039
P45 0070802	15.00	7.50	3.20	OR 26200710	P45 0497101	65.00	49.50	6.30	OR 53304699
P45 0080801	16.00	8.50	3.20	OR 26200800	P45 0527101	65.00	52.00	4.50	OR 57005160
P45 0170803	17.60	22.00	2.05	OR 15001700	<b>P45 0540801</b>	<b>65.00</b>	<b>54.00</b>	<b>4.20</b>	<b>OR 35305357</b>
P45 0100801	18.00	10.50	3.20	OR 26201000	<b>P45 0547101</b>	<b>70.00</b>	<b>54.50</b>	<b>6.30</b>	<b>OR 53305334</b>
P45 0120801	20.00	12.50	3.20	OR 26201191	<b>P45 0597101</b>	<b>70.00</b>	<b>59.00</b>	<b>4.20</b>	<b>OR 35305674</b>
<b>P45 0140801</b>	<b>22.00</b>	<b>14.50</b>	<b>3.20</b>	<b>OR 26201394</b>	P45 0590802	75.00	59.50	6.30	OR 53305652
P45 0160801	24.00	16.50	3.20	OR 26201588	<b>P45 0640803</b>	<b>75.00</b>	<b>64.00</b>	<b>4.20</b>	<b>OR 35306309</b>
<b>P45 0140802</b>	<b>25.00</b>	<b>14.00</b>	<b>4.20</b>	<b>OR 35301387</b>	<b>P45 0590803</b>	<b>80.00</b>	<b>59.00</b>	<b>8.10</b>	<b>OR 69905730</b>
<b>P45 0170801</b>	<b>25.00</b>	<b>17.50</b>	<b>3.20</b>	<b>OR 26201712</b>	<b>P45 0647101</b>	<b>80.00</b>	<b>64.50</b>	<b>6.30</b>	<b>OR 53306287</b>
P45 0180801	26.00	18.50	3.20	OR 26201796	<b>P45 0690803</b>	<b>80.00</b>	<b>69.00</b>	<b>4.20</b>	<b>OR 35306627</b>
<b>P45 0200801</b>	<b>28.00</b>	<b>20.50</b>	<b>3.20</b>	<b>OR 26202029</b>	<b>P45 0697101</b>	<b>85.00</b>	<b>69.50</b>	<b>6.30</b>	<b>OR 53306922</b>
<b>P45 0220801</b>	<b>30.00</b>	<b>22.50</b>	<b>3.20</b>	<b>OR 26202189</b>	P45 0690802	90.00	69.00	8.10	OR 69906800
P45 0210801	32.00	21.00	4.20	OR 35302022	<b>P45 0747101</b>	<b>90.00</b>	<b>74.50</b>	<b>6.30</b>	<b>OR 53307239</b>
<b>P45 0240801</b>	<b>32.00</b>	<b>24.50</b>	<b>3.20</b>	<b>OR 26202347</b>	<b>P45 0797101</b>	<b>95.00</b>	<b>79.50</b>	<b>6.30</b>	<b>OR 53307874</b>
<b>P45 0270801</b>	<b>35.00</b>	<b>27.50</b>	<b>3.20</b>	<b>OR 26202664</b>	P45 0797102	100.00	79.00	8.10	OR 69907800
<b>P45 0280801</b>	<b>36.00</b>	<b>28.50</b>	<b>3.20</b>	<b>OR 26202824</b>	<b>P45 0847101</b>	<b>100.00</b>	<b>84.50</b>	<b>6.30</b>	<b>OR 53308192</b>
<b>P45 0300801</b>	<b>38.00</b>	<b>30.50</b>	<b>3.20</b>	<b>OR 26202982</b>	<b>P45 0897101</b>	<b>105.00</b>	<b>89.50</b>	<b>6.30</b>	<b>OR 53308827</b>
<b>P45 0290801</b>	<b>40.00</b>	<b>29.00</b>	<b>4.20</b>	<b>OR 35302817</b>	P45 0897102	110.00	89.00	8.10	OR 69908800
<b>P45 0310802</b>	<b>42.00</b>	<b>31.00</b>	<b>4.20</b>	<b>OR 35302974</b>	<b>P45 0947101</b>	<b>110.00</b>	<b>94.50</b>	<b>6.30</b>	<b>OR 53309144</b>
<b>P45 0340801</b>	<b>45.00</b>	<b>34.00</b>	<b>4.20</b>	<b>OR 35303292</b>	P45 0947102	115.00	94.00	8.10	OR 69909100
<b>P45 0377101</b>	<b>48.00</b>	<b>37.00</b>	<b>4.20</b>	<b>OR 35303609</b>	<b>P45 0997101</b>	<b>115.00</b>	<b>99.50</b>	<b>6.30</b>	<b>OR 53309779</b>
P45 0340805	50.00	34.50	6.30	OR 53303269	P45 0990802	120.00	99.00	8.10	OR 69909800
<b>P45 0390801</b>	<b>50.00</b>	<b>39.00</b>	<b>4.20</b>	<b>OR 35303769</b>	<b>P45 1047101</b>	<b>120.00</b>	<b>104.50</b>	<b>6.30</b>	<b>OR 53310414</b>
P45 0410801	52.00	41.00	4.20	OR 35304000	P45 1040802	125.00	104.00	8.10	OR 69910300
P45 0440801	55.00	44.00	4.20	OR 35304285	<b>P45 1097103</b>	<b>125.00</b>	<b>109.50</b>	<b>6.30</b>	<b>OR 53310732</b>
P45 0450801	56.00	45.00	4.20	OR 35304470	<b>P45 1090803</b>	<b>130.00</b>	<b>109.00</b>	<b>8.10</b>	<b>OR 69910800</b>

## DOUBLE ACTING COMPACT SEAL

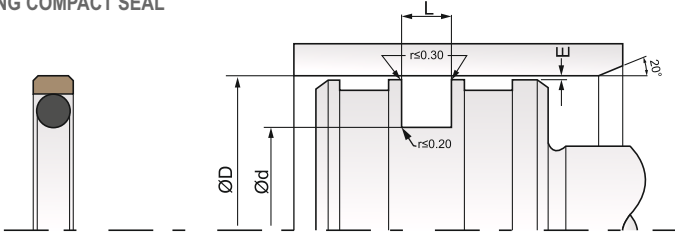

Max Spare Part No.	D (H9)	d (h9)	L (+0.2)	O'Ring Part No.	Max Spare Part No.	D (H9)	d (h9)	L (+0.2)	O'Ring Part No.
P45 1147103	130.00	114.30	6.30	OR 53311367	P45 2190801	240.00	219.00	8.10	OR 69921527
<b>P45 1140801</b>	<b>130.00</b>	<b>114.50</b>	<b>6.30</b>	<b>OR 53311367</b>	P45 2290801	250.00	229.00	8.10	OR 69922797
P45 1140802	135.00	114.00	8.10	OR 69911200	P45 2340802	255.00	234.00	8.10	OR 70023000
<b>P45 1197101</b>	<b>140.00</b>	<b>119.00</b>	<b>8.10</b>	<b>OR 69911684</b>	P45 2390801	260.00	239.00	8.10	OR 69923600
<b>P45 1240802</b>	<b>140.00</b>	<b>124.50</b>	<b>6.30</b>	<b>OR 53312319</b>	P45 2497001	270.00	249.00	8.10	OR 69924067
<b>P45 1240801</b>	<b>145.00</b>	<b>124.00</b>	<b>8.10</b>	<b>OR 69912319</b>	P45 2590801	280.00	259.00	8.10	OR 69925337
<b>P45 1290803</b>	<b>145.00</b>	<b>129.50</b>	<b>6.30</b>	<b>OR 53312637</b>	P45 2890801	289.00	310.00	8.10	OR 69928600
<b>P45 1290801</b>	<b>150.00</b>	<b>129.00</b>	<b>8.10</b>	<b>OR 69912637</b>	P45 2690801	290.00	269.00	8.10	OR 69926607
<b>P45 1340802</b>	<b>150.00</b>	<b>134.50</b>	<b>6.30</b>	<b>OR 53313272</b>	P45 2790801	300.00	279.00	8.10	OR 69927750
<b>P45 1340801</b>	<b>155.00</b>	<b>134.00</b>	<b>8.10</b>	<b>OR 69913272</b>	P452890801	310.00	289.00	8.10	OR 69928600
<b>P45 1390801</b>	<b>160.00</b>	<b>139.00</b>	<b>8.10</b>	<b>OR 69913589</b>	P45 3150802	315.00	340.00	8.10	OR 69931400
<b>P45 1440802</b>	<b>160.00</b>	<b>144.50</b>	<b>6.30</b>	<b>OR 53314224</b>	P453150802	340.00	315.50	8.10	OR 69931400
<b>P45 1440801</b>	<b>165.00</b>	<b>144.00</b>	<b>8.10</b>	<b>OR 69914224</b>	P45 3250801	350.00	325.50	8.10	OR 70032200
<b>P45 1490801</b>	<b>170.00</b>	<b>149.00</b>	<b>8.10</b>	<b>OR 69914859</b>	P45 2990801	320.00	299.00	8.10	OR 69929750
P45 1540801	175.00	154.00	8.10	OR 69915177	P45 3250801	325.50	350.00	8.10	OR 69931687
P45 1590801	180.00	159.00	8.10	OR 69915812	P45 3450801	345.50	370.00	8.10	OR 69934227
<b>P45 1640802</b>	<b>180.00</b>	<b>164.50</b>	<b>6.30</b>	<b>OR 53316447</b>	P45 3350801	360.00	335.50	8.10	OR 69932957
P45 1640801	185.00	164.00	8.10	OR 69916129	P45 3550801	380.00	355.50	8.10	OR 69935000
P45 1690801	190.00	169.00	8.10	OR 69916447	P45 3650801	390.00	365.50	8.10	OR 69935600
P45 1740801	195.00	174.00	8.10	OR 69917082	P45 3750801	400.00	375.50	8.10	OR 69937000
P45 1790801	200.00	179.00	8.10	OR 69917717	P45 3950801	420.00	395.50	8.10	OR 69939307
<b>P45 1840801</b>	<b>200.00</b>	<b>184.50</b>	<b>6.30</b>	<b>OR 53318352</b>	P45 4250801	450.00	425.50	8.10	OR 69941796
P45 1890801	210.00	189.00	8.10	OR 69918644	P454850801	485.50	510.00	8.10	OR 69948146
P45 1990801	220.00	199.00	8.10	OR 69919622	P45 4750801	500.00	475.50	8.10	OR 69946876
P45 2040802	225.00	204.00	8.10	OR 70020100	P45 5250801	550.00	525.50	8.10	OR 69952100
P45 2090801	230.00	209.00	8.10	OR 69920257	P45 5750801	600.00	575.50	8.10	OR 69956500
P45 2340802	234.00	255.00	8.10	OR 70023000					

- Bold sizes are available with FKM (Viton®) O-Ring also.
- Proper installation tool is recommended for P45 type piston seal, consult our sales team for tool and also watch installation procedure on <https://www.youtube.com/watch?v=2DfTLfCdE>

## SINGLE ACTING U SEAL

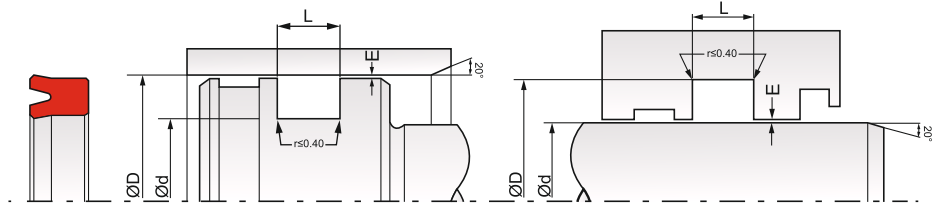

### MATERIAL :

Polyurethane compound of shore 92 'A'

### MAX OPERATING CONDITIONS :

Temp.	-30°C to +100 °C	Pressure	400 BAR	Speed	1.0 mtr./sec.
-------	------------------	----------	---------	-------	---------------

Max Spare Part No.	D (H9)	d (h9)	L (+0.2)	H	Max Spare Part No.	D (H9)	d (h9)	L (+0.2)	H
E07005L501	12.00	5.00	6.00	5.00	E07016L511	24.00	16.00	6.00	5.00
E07006L501	12.00	6.00	6.50	5.50	E07016L503	24.00	16.00	6.80	5.80
E07008L510	14.00	8.00	7.00	6.00	E07017L501	24.00	17.00	6.00	5.00
E07008L519	16.00	8.00	7.00	6.00	E07018L503	24.00	18.00	10.00	9.00
E07008L502	16.00	8.00	6.70	5.70	E07014L504	25.00	14.00	7.00	6.00
E07010L507	16.00	10.00	5.00	4.00	E07015L501	25.00	15.00	8.00	7.30
E07010L514	16.00	10.00	7.00	6.00	E07015L503	25.00	15.00	11.00	10.00
E07012L508	16.00	12.00	6.50	5.50	E07017L509	25.00	17.00	6.00	5.00
E07011L502	17.00	11.00	8.00	7.00	E07017L502	25.00	17.00	6.70	5.70
E07010L501	18.00	10.00	6.00	5.00	E07018L506	25.00	18.00	6.00	5.00
E07010L505	18.00	10.00	8.00	7.00	E07016L502	26.00	16.00	6.00	5.00
E07012L501	18.00	12.00	7.00	6.00	E07016L522	26.00	16.00	9.00	8.00
E07010L508	19.00	10.00	9.00	8.00	E07018L501	26.00	18.00	6.00	5.00
E07012L513	19.00	12.00	6.00	5.00	E07018L504	26.00	18.00	6.50	5.50
E07010L503	20.00	10.00	6.00	5.00	E07020L532	26.00	20.00	5.00	4.00
E07010L529	20.00	10.00	9.00	8.00	E07021L501	26.00	21.00	6.00	5.00
E07012L503	20.00	12.00	5.40	4.40	E07016L506	26.50	16.00	9.00	8.00
E07012L517	20.00	12.00	6.00	5.00	E07019L501	27.00	19.00	6.00	5.00
E07012L505	20.00	12.00	6.80	5.80	E07018L502	28.00	18.00	8.00	7.30
E07012L528	20.00	12.00	7.40	6.40	E07018L534	28.00	18.00	9.00	8.00
E07012L509	20.00	12.00	9.00	8.00	E07019L503	28.00	19.00	6.70	5.70
E07012L504	22.00	12.00	8.00	7.30	E07020L504	28.00	20.00	6.00	5.00
E07012L506	22.00	12.00	9.00	8.00	E07020L501	28.00	20.00	7.00	6.00
E07014L512	22.00	14.00	6.00	5.00	E07015L504	30.00	15.00	8.00	7.00
E07014L503	22.00	14.00	7.00	6.00	E07018L505	30.00	18.00	9.00	8.00
E07016L505	22.00	16.00	5.00	4.00	E07019L502	30.00	19.00	8.00	7.00
E07016L504	22.00	16.00	6.50	5.50	E07020L524	30.00	20.00	8.00	7.00
E07012L510	23.00	12.00	6.75	5.75	E07020L505	30.00	20.00	9.00	8.00
E07012L511	24.00	12.00	7.00	6.00	E07020L503	30.00	20.00	11.00	10.00
E07014L502	24.00	14.00	7.00	6.00	E07022L520	30.00	22.00	7.00	6.00
E07015L505	24.00	15.00	8.00	7.00	E07022L517	30.00	22.00	6.00	5.00

## SINGLE ACTING U SEAL

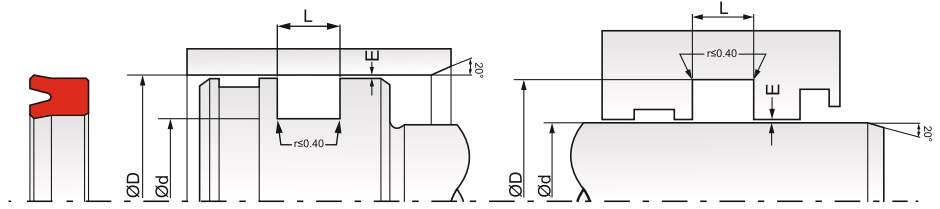

Max Spare Part No.	D (H9)	d (h9)	L (+0.2)	H	Max Spare Part No.	D (H9)	d (h9)	L (+0.2)	H
E07022L501	32.00	22.00	8.00	7.30	E07030L504	40.00	30.00	7.00	6.00
E07022L504	32.00	22.00	9.00	8.00	E07030L505	40.00	30.00	8.00	7.00
E07024L504	32.00	24.00	6.70	5.70	E07030L527	40.00	30.00	9.00	8.00
E07025L507	33.00	25.00	6.00	5.00	E07030L502	40.00	30.00	10.00	9.00
E07025L533	33.00	25.00	7.00	6.00	E07030L503	40.00	30.00	11.00	10.00
E07025L505	33.00	25.00	6.80	5.80	E07032L514	40.00	32.00	6.00	5.00
E07025L503	33.00	25.00	9.00	8.00	E07032L513	40.00	32.00	6.80	5.80
E07022L506	35.00	22.00	8.00	7.00	E07032L501	40.00	32.00	9.00	8.00
E07025L514	35.00	25.00	7.00	6.00	E07031L501	41.50	31.50	7.00	6.00
E07025L506	35.00	25.00	8.00	7.00	E07032L502	42.00	32.00	6.50	5.50
E07025L547	35.00	25.00	8.00	7.30	E07032L507	42.00	32.00	7.00	6.00
E07025L504	35.00	25.00	9.00	8.00	E07032L550	42.00	32.00	8.00	7.30
E07027L505	35.00	27.00	6.00	5.00	E07032L527	42.00	32.00	9.00	8.00
E07028L535	35.00	28.00	6.00	5.00	E07028L507	43.00	28.00	7.00	6.00
E07028L502	35.50	28.00	6.00	5.00	E07035L511	43.00	35.00	7.00	6.00
E07024L503	36.00	24.00	7.50	6.50	E07035L506	43.00	35.00	9.00	8.00
E07028L531	36.00	28.00	7.00	6.00	E07022L505	45.00	22.00	11.00	10.00
E07028L508	36.00	28.00	6.40	5.40	E07025L526	45.00	25.00	11.00	10.00
E07028L506	36.00	28.00	9.00	8.00	E07030L509	45.00	30.00	9.00	8.00
E07025L538	38.00	25.00	8.00	7.00	E070305907	45.00	30.00	10.00	9.00
E07025L511	38.00	25.00	9.00	8.00	E07030L514	45.00	30.00	11.00	10.00
E07025L508	38.00	25.00	10.00	9.00	E07032L506	45.00	32.00	9.00	8.00
E07025L501	38.00	25.00	11.00	10.00	E07032L504	45.00	32.00	11.00	10.00
E07025L509	38.00	25.00	13.00	12.00	E07034L502	45.00	34.00	8.00	7.00
E07028L504	38.00	28.00	8.00	7.00	E07035L502	45.00	35.00	7.00	6.00
E07030L507	38.00	30.00	6.70	5.70	E07035L507	45.00	35.00	8.00	7.00
E07030L535	38.00	30.00	7.00	6.00	E07035L513	45.00	35.00	9.00	8.00
E07030L506	38.00	30.00	8.00	7.00	E07035L504	45.00	35.00	11.00	10.00
E07030L508	39.00	30.00	9.00	8.00	E07035L505	45.00	35.50	7.00	6.00
E07020L507	40.00	20.00	11.00	10.00	E07038L501	45.00	38.00	9.00	8.00
E07024L501	40.00	24.00	9.00	8.00	E07036L503	46.00	36.00	8.00	7.00
E07025L513	40.00	25.00	9.00	8.00	E07036L519	46.00	36.00	9.00	8.00
E07025L512	40.00	25.00	11.00	10.00	E07032L503	48.00	32.00	11.00	10.00
E07025L510	40.00	25.00	13.00	12.00	E07035L512	48.00	35.00	10.00	9.00
E07027L501	40.00	27.00	11.00	10.00	E07038L502	48.00	38.00	9.00	8.00
E07028L503	40.00	28.00	11.00	10.00	E07040L507	48.00	40.00	9.00	8.00
E07030L534	40.00	30.00	6.00	5.00	E07030L510	50.00	30.00	11.00	10.00

## SINGLE ACTING U SEAL

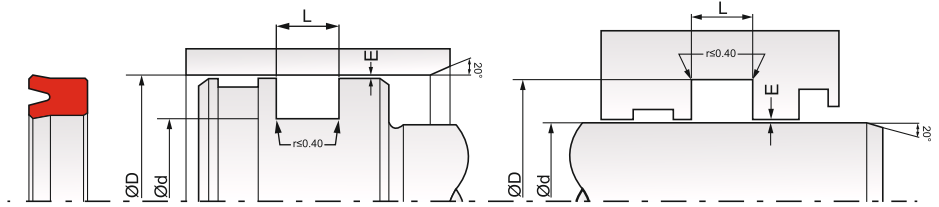

Max Spare Part No.	D (H9)	d (h9)	L (+0.2)	H	Max Spare Part No.	D (H9)	d (h9)	L (+0.2)	H
E07034L503	50.00	34.00	13.00	12.00	E07050L502	60.00	50.00	7.00	6.00
E07035L508	50.00	35.00	9.00	8.00	E07050L506	60.00	50.00	8.00	7.30
E07035L503	50.00	35.00	11.00	10.00	E07050L508	60.00	50.00	9.00	8.00
E07035L509	50.00	35.00	12.00	11.00	E07050L503	60.00	50.00	11.00	10.00
E07036L504	50.00	36.00	9.00	8.00	E07050L509	60.00	50.00	13.00	12.00
E07038L512	50.00	38.00	8.50	7.50	E07045L511	62.00	45.00	9.50	8.50
E07038L506	50.00	38.00	11.00	10.00	E07050L510	62.00	50.00	9.50	8.50
E07040L508	50.00	40.00	6.00	5.00	E07050L523	62.00	50.00	11.00	10.00
E07040L503	50.00	40.00	7.00	6.00	E07045L512	63.00	45.00	10.00	9.00
E07040L505	50.00	40.00	8.00	7.00	E07045L502	63.00	45.00	11.00	10.00
E07040L523	50.00	40.00	8.00	7.30	E07045L518	63.00	45.00	13.00	12.00
E07040L524	50.00	40.00	8.50	7.50	E07048L501	63.00	48.00	11.00	10.00
E07040L509	50.00	40.00	9.00	8.00	E07048L508	63.00	48.00	13.00	12.00
E07040L504	50.00	40.00	11.00	10.00	E07050L518	63.00	50.00	7.50	6.50
E07040L510	50.00	40.00	13.00	12.00	E07050L516	63.00	50.00	9.00	8.00
E07042L501	50.00	42.00	6.00	5.00	E07050L517	63.00	50.00	10.00	9.00
E07042L506	50.00	42.00	11.00	10.00	E07050L511	63.00	50.00	11.00	10.00
E07035L514	52.00	35.00	11.00	10.00	E07050L526	63.00	50.00	16.00	15.00
E07044L503	52.00	44.00	6.50	5.50	E07053L505	63.00	53.00	7.00	6.00
E07045L509	53.00	45.00	10.30	9.30	E07053L510	63.00	53.00	7.50	6.50
E07040L501	55.00	40.00	11.00	10.00	E07053L503	63.00	53.00	8.00	7.30
E07045L503	55.00	45.00	7.00	6.00	E07053L514	63.00	53.00	11.00	10.00
E07045L507	55.00	45.00	8.00	7.00	E07053L504	63.00	53.00	13.50	12.50
E07045L524	55.00	45.00	8.50	7.50	E07051L505	63.00	51.00	15.00	14.00
E07045L536	55.00	45.00	9.00	8.00	E07053L511	63.00	53.00	8.00	7.00
E07045L501	55.00	45.00	11.00	10.00	E07053L518	63.00	53.00	9.00	8.00
E07045L504	56.00	45.00	8.00	7.30	E07035L501	65.00	35.00	16.00	15.00
E07045L510	56.00	45.00	11.00	10.00	E07040L513	65.00	40.00	11.00	10.00
E07042L502	57.00	42.00	9.00	8.00	E07040L506	65.00	40.00	13.00	12.00
E07045L521	57.00	45.00	7.00	6.00	E07045L513	65.00	45.00	11.00	10.00
E07048L504	57.00	48.00	11.00	10.00	E07045L516	65.00	45.00	13.00	12.00
E07040L502	60.00	40.00	11.00	10.00	E07050L512	65.00	50.00	8.00	7.00
E07040L511	60.00	40.00	13.00	12.00	E07050L504	65.00	50.00	11.00	10.00
E07043L501	60.00	43.00	7.00	6.00	E07050L505	65.00	50.00	12.40	11.40
E07045L505	60.00	45.00	11.00	10.00	E07055L512	65.00	55.00	7.00	6.00
E07045L519	60.00	45.00	12.00	11.00	E07055L503	65.00	55.00	9.00	8.00
E07045L506	60.00	45.00	13.00	12.00	E07055L504	65.00	55.00	11.00	10.00

## SINGLE ACTING U SEAL

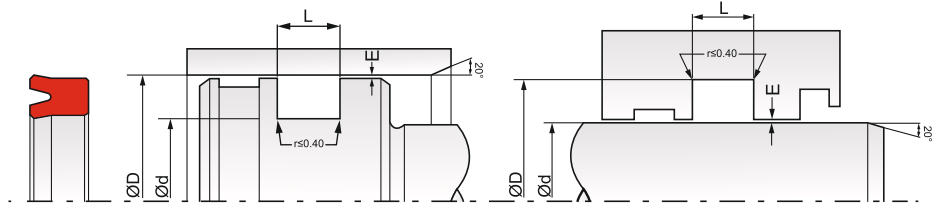

Max Spare Part No.	D (H9)	d (h9)	L (+0.2)	H	Max Spare Part No.	D (H9)	d (h9)	L (+0.2)	H
E07055L502	65.00	55.00	13.00	12.00	E07065L501	75.00	65.00	12.40	11.40
E07050L513	66.00	50.00	11.00	10.00	E07065L511	75.00	65.00	13.00	12.00
E07056L507	66.00	56.00	7.00	6.00	E07063L507	78.00	63.00	9.00	8.00
E07056L502	66.00	56.00	11.00	10.00	E07060L508	80.00	60.00	11.00	10.00
E07045L514	68.00	45.00	13.00	12.00	E07060L502	80.00	60.00	13.00	12.00
E07055L505	68.00	55.00	11.00	10.00	E07063L508	80.00	63.00	11.00	10.00
E07050L514	70.00	50.00	11.00	10.00	E07063L509	80.00	63.00	13.00	12.00
E07050L501	70.00	50.00	12.00	11.00	E07065L506	80.00	65.00	10.00	9.00
E07050L519	70.00	50.00	13.00	12.00	E07065L507	80.00	65.00	11.00	10.00
E07050L515	70.00	50.00	15.00	14.00	E07065L503	80.00	65.00	13.00	12.00
E07055L506	70.00	55.00	8.00	7.00	E07068L504	80.00	68.00	15.00	14.00
E07055L524	70.00	55.00	11.00	10.00	E07070L501	80.00	70.00	7.00	6.00
E07055L509	70.00	55.00	13.00	12.00	E07070L542	80.00	70.00	8.00	7.00
E07056L503	70.00	56.00	9.00	8.00	E07070L507	80.00	70.00	9.00	8.00
E07056L504	70.00	56.00	11.00	10.00	E07070L525	80.00	70.00	11.00	10.00
E07060L506	70.00	60.00	7.00	6.00	E07070L503	80.00	70.00	13.00	12.00
E07060L503	70.00	60.00	8.20	7.20	E07071L502	80.00	71.00	7.00	6.00
E07060L512	70.00	60.00	9.00	8.00	E07065L502	85.00	65.00	13.00	12.00
E07060L501	70.00	60.00	11.00	10.00	E07070L508	85.00	70.00	13.00	12.00
E07060L511	70.00	60.00	13.00	12.00	E07075L510	85.00	75.00	9.00	8.00
E07063L503	70.00	63.00	6.00	5.00	E07075L503	85.00	75.00	13.00	12.00
E07056L505	71.00	56.00	11.00	10.00	E07065L508	90.00	65.00	13.00	12.00
E07056L501	71.00	56.00	12.50	11.50	E07070L506	90.00	70.00	11.00	10.00
E07062L502	72.00	62.00	9.00	8.00	E07070L502	90.00	70.00	13.00	12.00
E07053L502	73.00	53.00	13.00	12.00	E07075L506	90.00	75.00	13.00	12.00
E07063L502	73.00	63.00	7.00	6.00	E07075L507	90.00	75.00	16.00	15.00
E07063L504	73.00	63.00	9.00	8.00	E07080L502	90.00	80.00	7.00	6.00
E07063L505	73.00	63.00	11.00	10.00	E07080L506	90.00	80.00	12.00	11.00
E07055L508	75.00	55.00	11.00	10.00	E07080L508	90.00	80.00	14.00	13.00
E07055L501	75.00	55.00	13.00	12.00	E07071L503	91.00	71.00	13.00	12.00
E07060L509	75.00	60.00	11.00	10.00	E07075L509	95.00	75.00	13.00	12.00
E07060L505	75.00	60.00	12.00	11.00	E07080L509	95.00	80.00	11.00	10.00
E07063L512	75.00	63.00	9.50	8.50	E07080L511	95.00	80.00	13.00	12.00
E07063L506	75.00	63.00	11.00	10.00	E07075L505	100.00	75.00	16.00	15.00
E07065L510	75.00	65.00	7.00	6.00	E07080L518	100.00	80.00	11.00	10.00
E07065L505	75.00	65.00	9.00	8.00	E07080L507	100.00	80.00	12.00	11.00
E07065L525	75.00	65.00	11.00	10.00	E07080L505	100.00	80.00	13.00	12.00

## SINGLE ACTING U SEAL

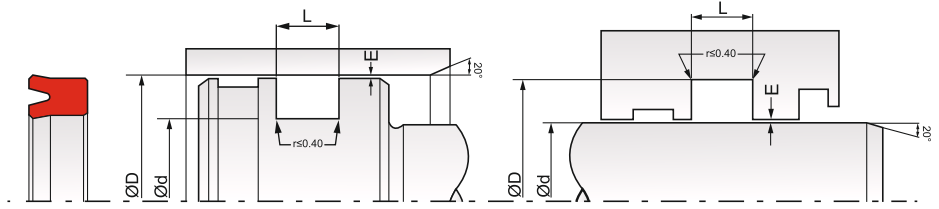

Max Spare Part No.	D (H9)	d (h9)	L (+0.2)	H	Max Spare Part No.	D (H9)	d (h9)	L (+0.2)	H
E07080L503	100.00	80.00	14.00	13.00	E07100L504	120.00	100.00	13.00	12.00
E07080L536	100.00	80.00	16.00	15.00	E07100L510	120.00	100.00	16.00	15.00
E07085L502	100.00	85.00	10.00	9.00	E07100L512	125.00	100.00	12.50	11.50
E07085L503	100.00	85.00	13.00	12.00	E07100L503	125.00	100.00	13.00	12.00
E07085L517	100.00	85.00	11.00	10.00	E07100L511	125.00	100.00	14.00	13.00
E07088L506	100.00	88.00	15.00	14.00	E07100L502	125.00	100.00	16.00	15.00
E07090L512	100.00	90.00	7.00	6.00	E07105L501	125.00	105.00	13.00	12.00
E07099L515	100.00	90.00	11.00	10.00	E07105L502	125.00	105.00	16.00	15.00
E07090L503	100.00	90.00	13.00	12.00	E07110L505	125.00	110.00	10.00	9.00
E07076L501	101.60	76.20	13.70	12.70	E07110L508	125.00	110.00	11.00	10.00
E07088L501	101.60	88.90	10.52	9.52	E07110L503	125.00	110.00	12.00	11.00
E07085L504	105.00	85.00	11.00	10.00	E07110L504	125.00	110.00	13.00	12.00
E07085L501	105.00	85.00	12.80	11.80	E07110L501	125.00	110.00	16.00	15.00
E07090L514	105.00	90.00	10.00	9.00	E07112L502	125.00	112.00	10.00	9.00
E07090L504	105.00	90.00	11.00	10.00	E07115L501	125.00	115.00	16.00	15.00
E07090L505	105.00	90.00	13.00	12.00	E07100L513	130.00	100.00	16.00	15.00
E07095L502	105.00	95.00	13.00	12.00	E07105L503	130.00	105.00	16.00	15.00
E07090L506	106.00	90.00	13.00	12.00	E07110L509	130.00	110.00	13.00	12.00
E07090L507	106.00	90.00	15.00	14.00	E07110L502	130.00	110.00	16.00	15.00
E07093L501	108.00	93.00	16.00	15.00	E07115L506	130.00	115.00	10.00	9.00
E07083L501	110.00	83.00	14.00	13.00	E07115L503	135.00	115.00	16.00	15.00
E07090L502	110.00	90.00	13.00	12.00	E07120L502	135.00	120.00	16.00	15.00
E07095L503	110.00	95.00	10.00	9.00	E07115L502	140.00	115.00	16.00	15.00
E07095L507	110.00	95.00	13.00	12.00	E07120L514	140.00	120.00	13.00	12.00
E07095L506	110.00	95.00	15.00	14.00	E07120L501	140.00	120.00	15.50	14.50
E07090L508	114.00	90.00	14.00	13.00	E07120L521	140.00	120.00	17.00	16.00
E07088L502	115.00	88.00	14.50	13.50	E07125L501	140.00	125.00	10.00	9.00
E07090L509	115.00	90.00	14.00	13.00	E07125L506	140.00	125.00	16.00	15.00
E07090L510	115.00	90.00	16.00	15.00	E07125L507	145.00	125.00	16.00	15.00
E07095L504	115.00	95.00	13.00	12.00	E07125L502	150.00	125.00	14.00	13.00
E07095L505	115.00	95.00	14.00	13.00	E07130L515	150.00	130.00	13.00	12.00
E07100L506	115.00	100.00	10.00	9.00	E07130L502	150.00	130.00	15.50	14.50
E07100L507	115.00	100.00	11.00	10.00	E07135L503	155.00	135.00	15.50	14.50
E07100L509	115.00	100.00	12.60	11.60	E07140L507	155.00	140.00	10.00	9.00
E07100L501	120.00	100.00	12.00	11.00	E07140L503	155.00	140.00	16.00	15.00

## SINGLE ACTING U SEAL

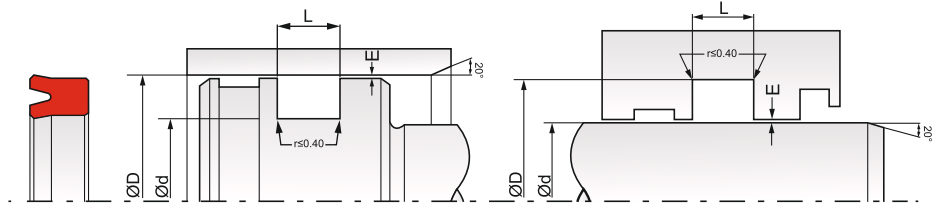

Max Spare Part No.	D (H9)	d (h9)	L (+0.2)	H	Max Spare Part No.	D (H9)	d (h9)	L (+0.2)	H
E07130L503	160.00	130.00	17.00	16.00	E07175L501	200.00	175.00	16.00	15.00
E07135L502	160.00	135.00	16.00	15.00	E07180L509	200.00	180.00	13.00	12.00
E07140L502	160.00	140.00	15.00	14.00	E07180L503	200.00	180.00	15.00	14.00
E07140L501	160.00	140.00	15.50	14.50	E07180L502	200.00	180.00	16.00	15.00
E07140L513	160.00	140.00	16.00	15.00	E07180L504	205.00	180.00	16.00	15.00
E07140L523	160.00	140.00	17.00	16.00	E07180L506	210.00	180.00	16.00	15.00
E07145L503	160.00	145.00	10.00	9.00	E07190L501	210.00	190.00	15.50	14.50
E07130L504	165.00	130.00	16.00	15.00	E07200L503	220.00	200.00	13.00	12.00
E07145L502	165.00	145.00	17.00	16.00	E07200L501	220.00	200.00	15.50	14.50
E07150L502	170.00	150.00	13.00	12.00	E07200L505	225.00	200.00	16.00	15.00
E07150L503	170.00	150.00	17.00	16.00	E07200L502	230.00	200.00	18.00	17.00
E07155L506	170.00	155.00	11.00	10.00	E07210L503	230.00	210.00	13.00	12.00
E07150L506	180.00	150.00	16.00	15.00	E07210L501	240.00	210.00	19.00	18.00
E07150L504	180.00	150.00	17.00	16.00	E07220L501	250.00	220.00	19.00	18.00
E07155L510	180.00	155.00	16.00	15.00	E07230L501	250.00	230.00	16.00	15.00
E07160L507	180.00	160.00	13.00	12.00	E07225L501	250.00	225.00	19.20	18.20
E07160L501	180.00	160.00	16.00	15.00	E07230L503	250.00	230.00	13.00	12.00
E07160L503	185.00	160.00	16.00	15.00	E07230L502	250.00	230.00	18.00	17.00
E07165L503	190.00	165.00	16.00	15.00	E07240L501	270.00	240.00	18.50	17.50
E07170L504	190.00	170.00	16.00	15.00	E07250L501	280.00	250.00	19.00	18.00
E07165L502	200.00	165.00	21.00	20.00	E07250L502	280.00	250.00	21.00	20.00
E07170L501	200.00	170.00	16.00	15.00	E07270L501	300.00	270.00	20.00	19.00
E07170L502	200.00	170.00	19.00	18.00	E07290L501	320.00	290.00	21.00	20.00

# S15 HYDRAULIC ROD SEAL

## SINGLE ACTING STEP SEAL

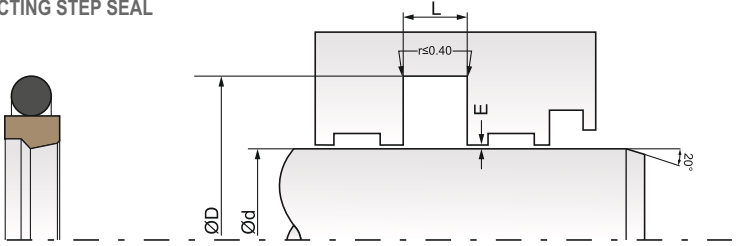

### MATERIAL :

O'RING : NBR 70 / 75 shore 'A'

SEALING RING : Bronze filled PTFE

### MAX OPERATING CONDITIONS :

Temp.	-30°C to +100 °C	Pressure	400 BAR	Speed	10.0 mtr./sec.
-------	------------------	----------	---------	-------	----------------

Max Spare Part No.	d (f8)	D (H9)	L (+0.2)	O'Ring Part No.	Max Spare Part No.	d (f8)	D (H9)	L (+0.2)	O'Ring Part No.
S15 0060801	6.00	10.90	2.20	OR 17800765	S15 0400801	40.00	50.70	4.20	OR 35304400
S15 0080801	8.00	12.90	2.20	OR 18000950	S15 0400802	40.00	55.10	6.30	OR 53304548
S15 0100801	10.00	14.90	2.20	OR 17800110	S15 0420801	42.00	52.70	4.20	OR 35304722
S15 0100802	10.00	17.30	3.20	OR 26201237	S15 0450801	45.00	55.70	4.20	OR 35305039
S15 0120801	12.00	16.90	2.20	OR 17801400	S15 0450802	45.00	60.10	6.30	OR 53305017
S15 0120802	12.00	19.30	3.20	OR 26201395	S150450806	45.00	62.00	6.00	OR 53305200
S150140801	14.00	18.90	2.20	OR 17801717	S15 0500801	50.00	60.70	4.20	OR 35305400
S15 0140802	14.00	21.30	3.20	OR 26201654	S15 0500802	50.00	65.10	6.30	OR 53305652
S15 0150802	15.00	22.30	3.20	OR 26201796	S15 0550801	55.00	65.70	4.20	OR 35305900
S15 0160801	16.00	20.90	2.20	OR 17801760	S15 0550802	55.00	70.10	6.30	OR 53306150
S15 0160802	16.00	23.30	3.20	OR 26201872	S15 0560801	56.00	66.70	4.20	OR 35306124
S15 0180802	18.00	25.30	3.20	OR 26202063	S15 0560802	56.00	71.10	6.30	OR 53306250
S15 0200801	20.00	27.30	3.20	OR 26202222	S15 0600801	60.00	70.70	4.20	OR 35306500
S15 0200802	20.00	30.70	4.20	OR 35302340	S15 0600802	60.00	75.10	6.30	OR 53306604
S15 0220801	22.00	29.30	3.20	OR 26202500	S15 0630801	63.00	78.10	6.30	OR 53306922
S15 0220802	22.00	32.70	4.20	OR 35302657	S15 0650801	65.00	80.10	6.30	OR 53307239
S15 0250801	25.00	32.30	3.20	OR 26202824	S150700804	70.00	80.70	4.20	OR 35007400
S15 0250802	25.00	35.70	4.20	OR 35302974	S15 0700801	70.00	85.10	6.30	OR 53307557
S15 0280801	28.00	35.30	3.20	OR 26203142	S15 0750803	75.00	85.70	4.20	OR 35307897
S15 0280802	28.00	38.70	4.20	OR 35303292	S15 0750801	75.00	90.10	6.30	OR 53308192
S15 0300802	30.00	40.70	4.20	OR 35303452	S15 0800803	80.00	90.70	6.30	OR 35308532
S15 0320801	32.00	39.30	3.20	OR 26203459	S15 0800801	80.00	95.10	6.30	OR 53308509
S15 0320802	32.00	42.70	4.20	OR 35303609	S15 0850801	85.00	100.10	6.30	OR 53309144
S15 0350802	35.00	42.30	3.20	OR 26203777	S15 0900801	90.00	105.10	6.30	OR 53309462
S15 0350801	35.00	45.70	4.20	OR 35303970	S15 0950801	95.00	110.10	6.30	OR 53310097
S15 0360801	36.00	43.30	3.20	OR 26203934	S15 1000801	100.00	115.10	6.30	OR 53310732
S15 0360802	36.00	46.70	4.20	OR 35304128	S15 1050801	105.00	120.10	6.30	OR 53311367
S15 0360808	36.00	47.00	4.20	OR 35304128	S15 1100801	110.00	125.10	6.30	OR 53311684
S15 0380801	38.00	48.70	4.20	OR 35304286	S15 1100802	110.00	130.50	8.10	OR 70011684
S15 0380802	38.00	53.10	6.30	OR 53304482	S15 1150801	115.00	130.10	6.30	OR 53312000

# S15 HYDRAULIC ROD SEAL

## SINGLE ACTING STEP SEAL

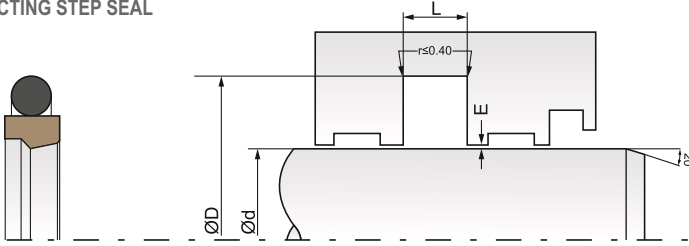

Max Spare Part No.	d (f8)	D (H9)	L (+0.2)	O'Ring Part No.	Max Spare Part No.	d (f8)	D (H9)	L (+0.2)	O'Ring Part No.
S15 1200801	120.00	135.10	6.30	OR 53312637	S15 2500801	250.00	270.50	8.10	OR 69925607
S15 1250801	125.00	140.10	6.30	OR 53313272	S15 2600801	260.00	284.00	8.10	OR 69926607
S15 1250802	125.00	145.50	8.10	OR 70012954	S15 2700801	270.00	294.00	8.10	OR 69927877
S15 1300801	130.00	145.10	6.30	OR 53313589	S15 2800801	280.00	304.00	8.10	OR 69929147
S15 1300802	130.00	150.50	8.10	OR 70013900	S15 2900801	290.00	314.00	8.10	OR 69930417
S15 1340803	134.00	149.50	6.30	OR 55014000	S15 3000801	300.00	324.00	8.10	OR 69931687
S15 1350801	135.00	150.10	6.30	OR 53314224	S15 3100801	310.00	334.00	8.10	OR 69932500
S15 1400801	140.00	155.10	6.30	OR 53314542	S15 3200801	320.00	344.00	8.10	OR 69932957
S15 1400802	140.00	160.50	8.10	OR 70014859	S15 3300802	330.00	354.00	8.10	OR 69934227
S15 1450801	145.00	160.10	6.30	OR 53315177	S15 3400801	340.00	364.00	8.10	OR 69935497
S15 1500801	150.00	165.10	6.30	OR 53315812	S15 3500801	350.00	374.00	8.10	OR 69936767
S15 1550801	155.00	170.10	6.30	OR 53315812	S15 3600801	360.00	384.00	8.10	OR 69936767
S15 1600801	160.00	175.10	6.30	OR 53316447	S15 3700801	370.00	394.00	8.10	OR 69938040
S15 1600802	160.00	180.50	8.10	OR 70017082	S15 3800802	380.00	404.00	8.10	OR 69939305
S15 1657001	165.00	180.10	6.30	OR 53317082	S15 3900801	390.00	414.00	8.10	OR 69940526
S15 1700801	170.00	185.10	6.30	OR 53317717	S15 4000801	400.00	424.00	8.10	OR 69941600
S15 1800801	180.00	195.10	6.30	OR 53318352	S15 4100801	410.00	434.00	8.10	OR 69942352
S15 1800802	180.00	200.50	8.10	OR 70018987	S15 4400801	440.00	464.00	8.10	OR 70045000
S15 1850801	185.00	200.10	6.30	OR 53318987	S15 4600801	460.00	484.00	8.10	OR 69948146
S15 1900801	190.00	205.10	6.30	OR 53319622	S15 4500801	450.00	474.00	8.10	OR 69946876
S15 1950802	195.00	210.10	6.30	OR 53320257	S15 4600801	460.00	484.00	8.10	OR 69948146
S152000804	200.00	215.10	6.30	OR 53320653	S154800801	480.00	504.00	8.10	OR 70049100
S15 2000801	200.00	220.50	8.10	OR 69921024	S154900801	490.00	514.00	8.10	OR 69950684
S15 2050802	205.00	225.00	8.10	OR 70021200	S15 5000801	500.00	524.00	8.10	OR 69950686
S15 2100801	210.00	230.50	8.10	OR 69921527	S155200802	520.00	544.00	8.10	OR 69953226
S15 2200801	220.00	240.50	8.10	OR 70022797	S155800801	580.00	604.00	8.10	OR 69959670
S15 2300801	230.00	250.50	8.10	OR 69924067	S15 6000801	600.00	624.00	8.10	OR 69960808
S152350801	235.00	255.50	8.10	OR 70024400	S156500801	650.00	677.30	9.50	OR 84068000
S15 2400801	240.00	260.50	8.10	OR 70024700	S157000802	700.00	727.00	9.50	OR 84071600

- Bold sizes are available with FKM (Viton®) O-Ring also.
- Proper installation tool is recommended for S15 type rod seal, consult our sales team for tool and also watch installation procedure on <https://www.youtube.com/watch?v=bAGkq1d3iow>

## SINGLE ACTING U SEAL

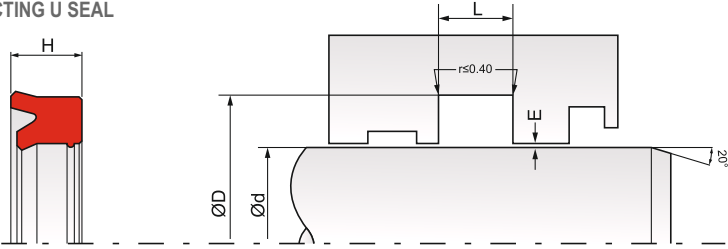

**MATERIAL:** Polyurethane 92<sup>o</sup>shore 'A'

### MAX OPERATING CONDITIONS :

Temp. -30°C to +100 °C

Pressure 300 BAR

Speed 1.0 mtr./sec.

Max Spare Part No.	d (f8)	D (H9)	L (+0.2)	H	Max Spare Part No.	d (f8)	D (H9)	L (+0.2)	H
S19006L501	6.00	14.00	6.50	5.50	S19025L505	25.00	33.00	6.70	5.70
S19008L502	8.00	16.00	6.70	5.70	S19025L515	25.00	33.00	7.00	6.00
S19010L507	10.00	15.00	4.00	5.00	S19025L506	25.00	33.00	8.00	7.30
S19010L501	10.00	18.00	6.50	5.50	S19025L501	25.00	35.00	6.70	5.70
S19012L512	12.00	19.00	4.00	5.00	S19025L534	25.00	38.00	8.00	7.00
S19012L505	12.00	20.00	6.70	5.70	S19025L502	25.00	35.00	8.00	7.30
S19012L503	12.00	22.00	8.00	7.30	S19025L504	25.00	35.00	9.00	8.00
S19014L502	14.00	21.00	6.00	5.00	S19025L507	25.00	35.00	11.00	10.00
S19014L501	14.00	24.00	8.00	7.30	S19026L501	26.00	33.00	9.00	8.00
S19016L501	16.00	22.00	5.50	4.50	S19028L517	28.00	36.00	7.00	6.00
S19016L503	16.00	23.00	6.00	5.00	S19028L503	28.00	36.00	8.00	7.30
S19016L502	16.00	24.00	6.70	5.70	S19028L501	28.00	38.00	8.00	7.30
S19016L504	16.00	26.00	8.00	7.30	S19028L516	28.00	38.00	9.00	8.00
S19018L502	18.00	24.00	5.80	4.80	S19030L503	30.00	38.00	9.00	8.00
S19018L508	18.00	25.00	6.00	5.00	S19030L525	30.00	40.00	7.00	6.00
S19018L506	18.00	26.00	6.70	5.70	S19030L504	30.00	40.00	7.50	6.50
S19018L510	18.00	28.00	8.00	7.30	S19030L501	30.00	40.00	8.00	7.30
S19018L503	18.00	28.00	9.00	8.00	S19030L505	30.00	40.00	9.00	8.00
S19019L503	19.00	25.00	7.00	6.00	S19030L502	30.00	40.00	11.00	10.00
S19019L502	19.00	30.00	8.00	7.00	S19030L509	30.00	45.00	11.00	10.00
S19020L505	20.00	26.00	5.00	4.00	S19032L513	32.00	40.00	6.70	5.70
S19020L531	20.00	28.00	6.00	5.00	S19032L504	32.00	42.00	6.70	5.70
S19020L502	20.00	28.00	6.70	5.70	S19032L502	32.00	42.00	8.00	7.30
S19020L506	20.00	28.00	7.30	6.30	S19032L501	32.00	42.00	11.00	10.00
S19020L504	20.00	30.00	6.70	5.70	S19032L503	32.00	47.00	11.00	10.00
S19020L503	20.00	30.00	8.00	7.30	S19035L512	35.00	45.00	7.00	6.00
S19020L507	20.00	30.00	11.00	10.00	S19035L513	35.00	45.00	8.00	7.00
S19022L502	22.00	29.00	6.00	5.00	S19035L502	35.00	45.00	8.00	7.30
S19022L501	22.00	30.00	6.70	5.70	S19035L514	35.00	45.00	9.00	8.00
S19022L504	22.00	32.00	8.00	7.30	S19035L506	35.00	45.00	11.00	10.00
S19022L515	22.00	32.00	9.00	8.00	S19035L503	35.00	46.00	8.00	7.30
S19025L514	25.00	33.00	6.00	5.00	S19035L507	35.00	50.00	11.00	10.00

## SINGLE ACTING U SEAL

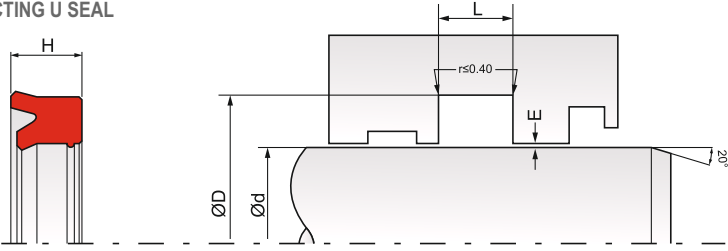

Max Spare Part No.	d (f8)	D (H9)	L (+0.2)	H	Max Spare Part No.	d (f8)	D (H9)	L (+0.2)	H
S19036L508	36.00	44.00	6.70	5.70	S19050L514	50.00	70.00	13.00	12.00
S19036L506	36.00	44.00	7.30	6.30	S19055L503	55.00	70.00	12.80	11.80
S19036L502	36.00	46.00	8.00	7.30	S19056L504	56.00	66.00	8.00	7.00
S19036L518	36.00	46.00	9.00	8.00	S19056L502	56.00	66.00	11.00	10.00
S19036L512	36.00	46.00	11.00	10.00	S19056L503	56.00	71.00	11.00	10.00
S19038L515	38.10	50.80	10.52	9.52	S19056L501	56.00	71.00	12.50	11.50
S19040L503	40.00	48.00	6.70	5.70	S19056L518	56.00	71.00	13.50	12.50
S19040L514	40.00	48.00	9.00	8.00	S19060L512	60.00	70.00	7.00	6.00
S19040L515	40.00	48.00	11.00	10.00	S19060L521	60.00	70.00	8.00	7.00
S19040L510	40.00	50.00	6.50	6.00	S19060L501	60.00	70.00	8.00	7.30
S19040L501	40.00	50.00	8.00	7.30	S19060L515	60.00	70.00	9.00	8.00
S19040L519	40.00	50.00	9.00	8.00	S19060L506	60.00	70.00	11.00	10.00
S19040L502	40.00	50.00	11.00	10.00	S19060L502	60.00	70.00	12.80	11.80
S19040L517	40.00	55.00	11.00	10.00	S19060L508	60.00	75.00	12.80	11.80
S19040L506	40.00	55.00	12.30	11.30	S19060L505	60.00	80.00	13.00	12.00
S19042L501	42.00	50.00	9.00	8.00	S19063L506	63.00	70.00	13.00	12.00
S19045L509	45.00	53.00	6.70	5.70	S19063L505	63.00	73.00	13.00	12.00
S19045L510	45.00	53.00	9.00	8.00	S19063L502	63.00	75.00	12.80	11.80
S19045L516	45.00	55.00	7.00	6.00	S19063L504	63.00	78.00	12.40	11.40
S19045L517	45.00	55.00	8.00	7.00	S19065L509	65.00	75.00	13.00	12.00
S19045L504	45.00	55.00	8.00	7.30	S19065L504	65.00	80.00	10.00	9.00
S19045L518	45.00	55.00	9.00	8.00	S19065L503	65.00	85.00	13.00	12.00
S19045L501	45.00	55.00	11.00	10.00	S19070L526	70.00	80.00	7.00	6.00
S19045L508	45.00	55.00	12.50	11.50	S19070L510	70.00	80.00	8.00	7.30
S19045L506	45.00	60.00	12.40	11.40	S19070L504	70.00	80.00	13.00	12.00
S19050L504	50.00	58.00	12.50	11.50	S19070L511	70.00	85.00	11.00	10.00
S19050L512	50.00	60.00	6.50	6.00	S19070L502	70.00	85.00	12.40	11.40
S19050L512	50.00	60.00	7.00	6.00	S19070L501	70.00	85.00	13.00	12.00
S19050L501	50.00	60.00	8.00	7.30	S19070L509	70.00	85.00	13.50	12.50
S19050L536	50.00	60.00	9.00	8.00	S19075L503	75.00	83.00	12.50	11.50
S19050L503	50.00	60.00	11.00	10.00	S19075L519	75.00	85.00	12.50	11.50
S19050L502	50.00	65.00	11.00	10.00	S19075L501	75.00	85.00	13.00	12.00
S19050L505	50.00	65.00	12.40	11.40	S19075L504	75.00	90.00	13.00	12.00
S19055L520	55.00	65.00	7.00	6.00	S19080L505	80.00	90.00	13.00	12.00
S19055L506	55.00	65.00	8.00	7.30	S19080L502	80.00	95.00	12.70	11.70
S19055L510	55.00	65.00	11.00	10.00	S19080L501	80.00	100.00	13.00	12.00
S19055L501	55.00	68.00	11.00	10.00	S19080L503	80.00	100.00	16.00	15.00

## SINGLE ACTING U SEAL

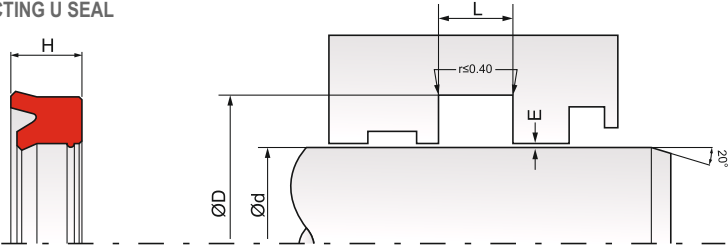

Max Spare Part No.	d (f8)	D (H9)	L (+0.2)	H	Max Spare Part No.	d (f8)	D (H9)	L (+0.2)	H
S19085L501	85.00	100.00	12.80	11.80	S19125L502	125.00	150.00	14.00	13.00
S19085L503	85.00	105.00	13.00	12.00	S19130L502	130.00	150.00	15.50	14.50
S19090L508	90.00	100.00	11.00	10.00	S19135L503	135.00	143.00	13.50	12.50
S19090L505	90.00	100.00	12.50	11.50	S19135L502	135.00	150.00	12.40	11.40
S19090L509	90.00	105.00	10.00	9.00	S19140L503	140.00	150.00	7.00	6.00
S19090L503	90.00	105.00	12.50	11.50	S19140L504	140.00	155.00	14.00	13.00
S19090L502	90.00	110.00	13.00	12.00	S19140L502	140.00	160.00	15.50	14.50
S19095L502	95.00	110.00	13.00	12.00	S19145L503	145.00	153.00	12.50	11.50
S19095L501	95.00	115.00	13.00	12.00	S19150L501	150.00	170.00	15.50	14.50
S19100L505	100.00	115.00	11.00	10.00	S19160L505	160.00	172.00	15.00	14.00
S19100L501	100.00	115.00	13.00	12.00	S19160L501	160.00	180.00	15.50	14.50
S19100L504	100.00	120.00	13.00	12.00	S19165L501	165.00	190.00	16.00	15.00
S19100L503	100.00	120.00	15.50	14.50	S19170L501	170.00	190.00	15.50	14.50
S19105L501	105.00	120.00	10.00	9.00	S19170L502	170.00	200.00	16.00	15.00
S19110L505	110.00	125.00	10.60	9.60	S19180L503	180.00	200.00	15.50	14.50
S19110L504	110.00	125.00	12.40	11.40	S19180L507	180.00	200.00	17.00	16.00
S19110L508	110.00	130.00	13.00	12.00	S19180L502	180.00	205.00	16.00	15.00
S19110L502	110.00	130.00	15.50	14.50	S19200L501	200.00	220.00	15.50	14.50
S19115L501	115.00	130.00	11.00	10.00	S19200L502	200.00	225.00	17.00	16.00
S19120L502	120.00	140.00	15.50	14.50	S19220L501	220.00	250.00	24.00	23.00
S19125L501	125.00	145.00	15.50	14.50	S19250L501	250.00	280.00	24.00	23.00

Use seal twistor tool for installing polyurethane rod seal, consult our sales team for this tool and also watch installation procedure on <https://www.youtube.com/watch?v=6lebY-XDV94>

# S59 / S60 HYDRAULIC ROD SEAL

## SINGLE ACTING VEE PACK

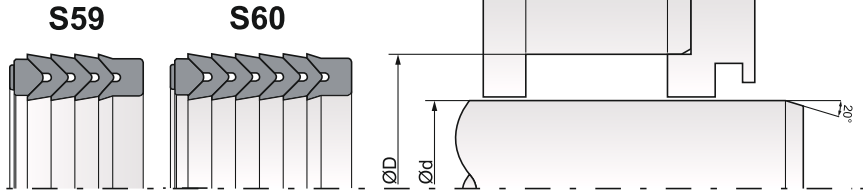

**MATERIAL :** Fabric Reinforced NBR



**MAX OPERATING CONDITIONS :**

Temp. -30°C to +100 °C

Pressure 400 BAR

Speed 0.5 mtr./sec.

Max Spare Part No.		d (f8)	D (H9)	S59 L (+0.2)	S60 L (+0.2)	Centre Ht. A
S59	S60					
S590188303	S600188303	18.00	28.00	19.86	26.50	3.31
S590208306	S600208306	20.00	32.00	16.86	22.50	2.81
S590228301	S600228301	22.00	38.00	25.98	34.66	4.33
S590258306	S600258306	25.00	40.00	25.50	34.00	4.25
S590288301	S600288301	28.00	40.00	16.98	22.66	2.83
S590288302	S600288309	28.00	43.00	22.50	30.00	3.75
S590308304	S600308301	30.00	40.00	21.78	29.06	3.63
S590308302	S600308303	30.00	45.00	22.20	29.60	3.70
S590308303	S600308304	30.00	50.00	29.34	39.15	4.89
S590318301	S600318301	31.75	44.45	19.02	25.39	3.17
S590348302	S600348302	34.90	50.80	24.18	32.27	4.03
S590358305	S600358303	35.00	50.00	24.72	33.00	4.12
S590358322	S600358317	35.00	47.00	17.10	22.80	2.85
S590368303	S600368303	36.00	50.00	22.08	29.50	3.68
S590368305	S600368305	36.00	48.00	16.86	22.50	2.81
S590388302	S600388302	38.10	50.80	19.44	25.93	3.24
S590408303	S600408302	40.00	55.00	22.62	30.16	3.77
S590408304	S600408304	40.00	56.00	17.52	23.43	2.92
S590408305	S600408305	40.00	60.00	30.00	40.00	5.00
S590408323	S600408308	40.00	52.00	16.86	22.50	2.81
S590458301	S600458302	45.00	60.00	22.26	29.70	3.71
S590488306	S600488303	48.00	63.00	28.50	38.00	4.75
S590508309	S600508308	50.80	69.80	33.48	44.66	5.58
S590508311	S600508310	50.00	70.00	33.72	45.00	5.62
S590508306	S600508319	50.00	65.00	25.20	33.60	4.20
S590538303	S600538303	53.97	69.85	25.26	33.69	4.21
S590558304	S600558304	55.00	75.00	38.46	51.32	6.41
S590568302	S600568302	56.00	76.00	33.30	44.40	5.55
S590608304	S600608304	60.00	80.00	31.56	42.15	5.26
S590638309	S600638308	63.00	80.00	27.00	36.00	4.50
S590638336	S600638327	63.00	78.00	24.00	32.00	4.00
S590658304	S600658302	65.00	80.00	25.98	34.66	4.33

# S59 / S60 HYDRAULIC ROD SEAL

## SINGLE ACTING VEE PACK

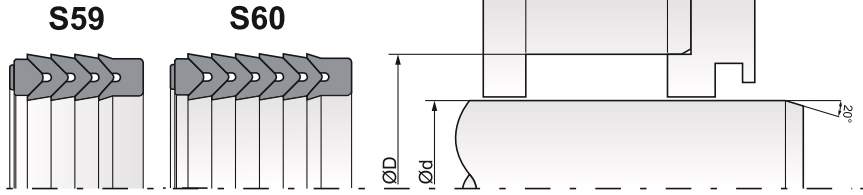

Max Spare Part No.		d (f8)	D (H9)	S59 L (+0.2)	S60 L (+0.2)	Centre Ht. A
S59	S60					
S590658302	S600658303	65.00	85.00	28.98	38.66	4.83
S590708306	S600708305	70.00	90.00	27.00	36.00	4.50
S590708321	S600708307	70.00	85.00	16.86	22.50	2.81
S590758302	S600758301	75.00	95.00	30.00	40.00	5.00
S590758304	S600758304	75.00	100.00	30.00	40.00	5.00
S590808301	S600808301	80.00	100.00	30.00	40.00	5.00
S590808302	S600808302	80.00	95.00	17.46	23.29	2.91
S590838301	S600828310	82.55	101.60	28.92	38.61	4.82
S590858302	S600858303	85.00	105.00	30.00	40.00	5.00
S590888304	S600888304	88.90	114.30	35.28	47.08	5.88
S590908305	S600908305	90.00	110.00	24.72	33.00	4.12
S590908302	S600908306	90.00	115.00	27.36	36.53	4.56
S590908307	S600908308	90.00	105.00	22.50	30.00	2.81
S590908310	S600908312	90.00	110.00	30.00	40.00	5.00
S590958303	S600958302	95.00	120.00	40.50	54.00	6.75
S590958906	S600958307	95.00	115.00	30.00	40.00	5.00
S591008307	S601008307	100.00	125.00	38.58	51.50	6.43
S591008324	S601008308	100.00	115.00	22.50	30.00	3.75
S591008325	S601008309	100.00	120.00	30.00	40.00	5.00
S591018301	S601018301	101.60	127.00	32.10	42.85	5.35
S591108301	S601108301	110.00	130.00	30.00	40.00	5.00
S591108304	S601108304	110.00	135.00	41.46	55.32	6.91
S591108305	S601108305	110.00	135.00	42.72	57.00	7.12
S591108313	S601108315	110.00	125.00	22.50	30.00	3.75
S591108322	S601108323	110.00	140.00	45.00	60.00	7.50
S591158301	S601158301	115.00	140.00	37.08	49.48	6.18
S591208304	S601208304	120.00	145.00	36.36	48.50	6.06
S591208305	S601208309	120.00	150.00	38.22	51.00	6.37
S591258303	S601258303	125.00	150.00	27.36	36.52	4.56
S591258304	S601258305	125.00	140.00	22.68	30.25	3.78
S591258323	S601258311	125.00	145.00	33.72	45.00	5.62
S591278301	S601278301	127.00	152.40	38.58	51.49	6.43
S591308302	S601308302	130.00	155.00	39.96	53.32	6.66
S591308303	S601308303	130.00	160.00	43.50	58.00	7.25
S591308301	S601308304	130.00	150.00	30.00	40.00	5.00
S591358303	S601358307	135.00	160.00	42.00	56.00	7.00
S591408303	S601408303	140.00	170.00	32.94	43.95	5.49

# S59 / S60 HYDRAULIC ROD SEAL

## SINGLE ACTING VEE PACK

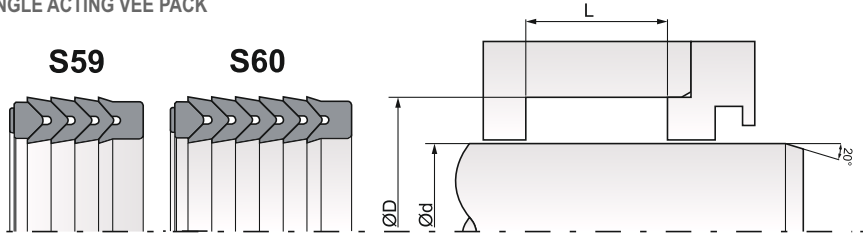

Max Spare Part No.		d (f8)	D (H9)	S59 L (+0.2)	S60 L (+0.2)	Centre Ht. A
S59	S60					
S591408304	S601408304	140.00	160.00	30.00	40.00	5.00
S591408315	S601408305	140.00	155.00	25.50	34.00	4.25
S591458301	S601458301	145.00	170.00	38.10	50.80	6.35
S591508304	S601508303	150.00	180.00	43.50	58.00	7.25
S591528301	S601528301	152.40	177.80	33.30	44.44	5.55
S591608301	S601608301	160.00	180.00	30.00	40.00	5.00
S591608302	S601608302	160.00	190.00	32.94	43.95	5.49
S591708303	S601708303	170.00	200.00	49.08	65.50	8.18
S591718306	S601718302	171.45	203.20	30.00	40.00	5.00
S591808303	S601808303	180.00	210.00	45.72	61.00	7.62
S591808308	S601808304	180.00	200.00	30.00	40.00	5.00
S592008304	S602008303	200.00	230.00	33.72	45.00	5.62
S592508303	S602508303	250.00	280.00	60.36	80.50	10.06

## MEDIUM DUTY WIPER SEAL

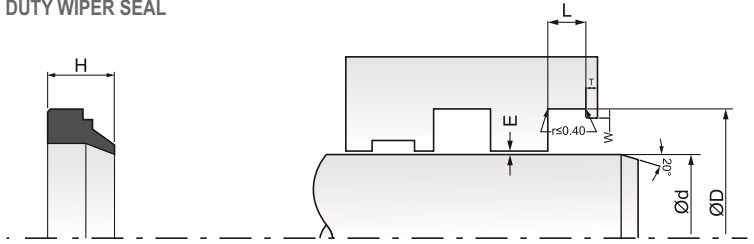

**MATERIAL :** NBR 85/ 90 Shore A ' '

**MAX OPERATING CONDITIONS :**

Temp. -30°C to +100 °C      Speed 1.0 mtr./sec.

Max Spare Part No.	d (f8)	D (H9)	L (+0.2)	H	T (+0.2)	W (+0.10)
W11 0101101	10.00	16.00	2.50	5.00	1.00	1.00
W11 0161101	16.00	24.00	4.00	7.00	1.00	1.00
W11 0181102	18.00	26.00	4.00	7.00	1.00	1.00
W11 0201101	20.00	28.00	4.00	7.00	1.00	1.00
W11 0221101	22.00	30.00	4.00	7.00	1.00	1.00
W11 0251101	25.00	33.00	4.00	7.00	1.00	1.00
W11 0281101	28.00	36.00	4.00	7.00	1.00	1.00
W11 0301101	30.00	38.00	4.00	7.00	1.00	1.00
W11 0321101	32.00	40.00	4.00	7.00	1.00	1.00
W11 0351101	35.00	43.00	4.00	7.00	1.00	1.00
W11 0361101	36.00	44.00	4.00	7.00	1.00	1.00
W11 0381101	38.00	46.00	4.00	7.00	1.00	1.00
W11 0401101	40.00	48.00	4.00	7.00	1.00	1.00
W11 0421101	42.00	50.00	4.00	7.00	1.00	1.00
W11 0451102	45.00	53.00	4.00	7.00	1.00	1.00
W11 0451101	45.00	57.00	5.50	10.00	1.50	1.50
W11 0501101	50.00	58.00	4.00	7.00	1.00	1.00
W11 0551101	55.00	63.00	4.00	7.00	1.00	1.00
W11 0561101	56.00	64.00	4.00	7.00	1.00	1.00
W11 0601101	60.00	68.00	4.00	7.00	1.00	1.00
W11 0631101	63.00	71.00	4.00	7.00	1.00	1.00
W11 0651101	65.00	73.00	4.00	7.00	1.00	1.00
W11 0701102	70.00	78.00	4.00	7.00	1.00	1.00
W11 0751101	75.00	83.00	4.00	7.00	1.00	1.00
W11 0801102	80.00	88.00	4.00	7.00	1.00	1.00
W11 0801101	80.00	92.00	5.50	10.00	1.00	1.00
W11 0851101	85.00	93.00	4.00	7.00	1.00	1.00
W11 0901101	90.00	98.00	4.00	7.00	1.00	1.00
W11 0951101	95.00	103.00	4.00	7.00	1.00	1.00
W11 1001101	100.00	108.00	4.00	7.00	1.00	1.00
W11 1051101	105.00	117.00	5.50	10.00	1.50	1.50
W11 1101103	110.00	117.00	8.20	11.00	1.50	1.50

## MEDIUM DUTY WIPER SEAL

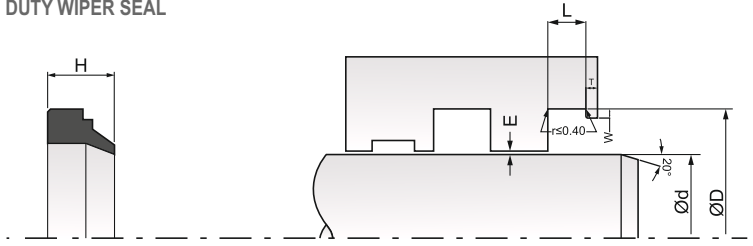

Max Spare Part No.	d (f8)	D (H9)	L (+0.2)	H	T (+0.2)	W (+0.10)
W11 1101101	110.00	118.00	4.00	7.00	1.00	1.00
W11 1101102	110.00	122.00	5.50	10.00	1.50	1.50
W11 1151101	115.00	127.00	5.50	10.00	1.50	1.50
W11 1201101	120.00	132.00	5.50	10.00	1.50	1.50
W11 1251101	125.00	137.00	5.50	10.00	1.50	1.50
W11 1301101	130.00	142.00	5.50	10.00	1.50	1.50
W11 1351101	135.00	147.00	5.50	10.00	1.50	1.50
W11 1401101	140.00	152.00	5.50	10.00	1.50	1.50
W11 1501101	150.00	162.00	5.50	10.00	1.50	1.50
W11 1601101	160.00	172.00	5.50	10.00	1.50	1.50
W11 1701101	170.00	182.00	5.50	10.00	1.50	1.50
W11 1801101	180.00	192.00	5.50	10.00	1.50	1.50
W11 1901101	190.00	202.00	5.50	10.00	1.50	1.50
W11 2001101	200.00	212.00	5.50	10.00	1.50	1.50
W11 2101102	210.00	225.00	6.50	13.00	2.00	2.00
W11 2201101	220.00	235.00	6.50	13.00	2.00	2.00
W11 2301101	230.00	245.00	6.50	13.00	2.00	2.00
W11 2401101	240.00	255.00	6.50	13.00	2.00	2.00
W11 2501101	250.00	265.00	6.50	13.00	2.00	2.00
W11 2601101	260.00	275.00	6.50	13.00	2.00	2.00
W11 3001101	300.00	315.00	6.50	13.00	2.00	2.00
W11 4001101	400.00	415.00	6.50	13.00	2.00	2.00

## MEDIUM DUTY WIPER SEAL

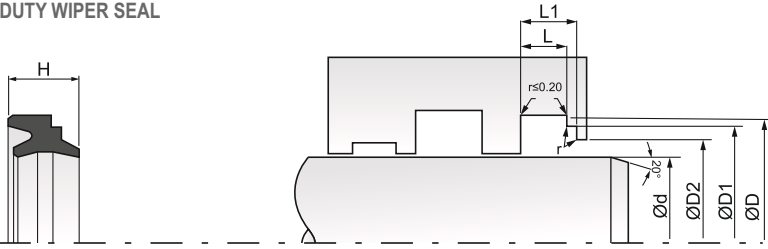

**MATERIAL :** NBR85/ 90Shore A ' '

**MAX OPERATING CONDITIONS :**

Temp.	-30°C to +100 °C	Speed	1.0 mtr./sec.
-------	------------------	-------	---------------

Max Spare Part No.	d (f8)	D (H9)	L1 (+0.20)	L (+0.20)	D2 (H9)	D1 (H9)	H
W12 0101101	10.00	18.00	6.00	4.00	13.50	16.00	8.00
W12 0121101	12.00	20.00	6.00	4.00	15.50	18.00	8.00
W12 0141104	14.00	22.00	6.00	4.00	17.50	20.00	8.00
W12 0151101	15.00	23.00	6.00	4.00	18.50	21.00	8.00
W12 0161101	16.00	24.00	6.00	4.00	19.50	22.00	8.00
W12 0181101	18.00	26.00	6.00	4.00	21.50	24.00	8.00
W12 0201101	20.00	28.00	6.00	4.00	23.50	26.00	8.00
W12 0221101	22.00	30.00	6.00	4.00	25.50	28.00	8.00
W12 0251101	25.00	33.00	6.00	4.00	28.50	31.00	8.00
W12 0281101	28.00	36.00	6.00	4.00	31.50	34.00	8.00
W12 0301101	30.00	38.00	6.00	4.00	33.50	36.00	8.00
W12 0321101	32.00	40.00	6.00	4.00	35.50	38.00	8.00
W12 0351101	35.00	43.00	6.00	4.00	38.50	41.00	8.00
W12 0361101	36.00	44.00	6.00	4.00	39.50	42.00	8.00
W12 0381101	38.00	46.00	6.00	4.00	41.50	44.00	8.00
W12 0401101	40.00	48.00	6.00	4.00	43.50	46.00	8.00
W12 0421101	42.00	50.00	6.00	4.00	45.50	48.00	8.00
W12 0451101	45.00	53.00	6.00	4.00	48.50	51.00	8.00
W12 0501101	50.00	58.00	6.00	4.00	53.50	56.00	8.00
W12 0551101	55.00	63.00	6.00	4.00	58.50	61.00	8.00
W12 0561101	56.00	64.00	6.00	4.00	59.50	62.00	8.00
W12 0601101	60.00	68.00	6.00	4.00	63.50	66.00	8.00
W12 0631101	63.00	71.00	6.00	4.00	66.50	69.00	8.00
W12 0651101	65.00	73.00	6.00	4.00	68.50	71.00	8.00
W12 0701101	70.00	78.00	6.00	4.00	73.50	76.00	8.00
W12 0751101	75.00	83.00	6.00	4.00	78.50	81.00	8.00
W12 0801101	80.00	88.00	6.00	4.00	83.50	86.00	8.00
W12 0851101	85.00	93.00	6.00	4.00	88.50	91.00	8.00
W12 0901101	90.00	98.00	6.00	4.00	93.50	96.00	8.00
W12 0951101	95.00	103.00	6.00	4.00	98.50	101.00	8.00
W12 1001101	100.00	108.00	6.00	4.00	103.50	106.00	8.00
W12 1051101	105.00	117.00	8.20	5.50	110.00	114.00	11.00

## MEDIUM DUTY WIPER SEAL

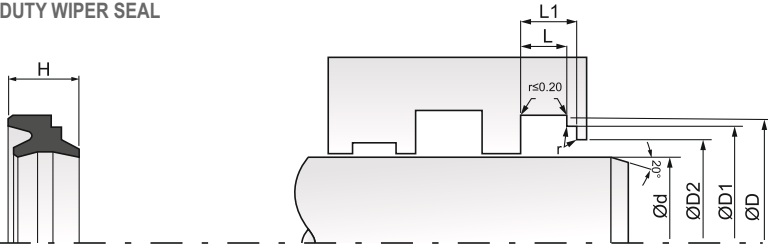

Max Spare Part No.	d (f8)	D (H9)	L1 (+0.20)	L (+0.20)	D2 (H9)	D1 (H9)	H
W12 1101101	110.00	122.00	8.20	5.50	115.00	119.00	11.00
W12 1151101	115.00	127.00	8.20	5.50	120.00	124.00	11.00
W12 1201101	120.00	132.00	8.20	5.50	125.00	129.00	11.00
W12 1251101	125.00	137.00	8.20	5.50	130.00	134.00	11.00
W12 1301101	130.00	142.00	8.20	5.50	135.00	139.00	11.00
W12 1351101	135.00	147.00	8.20	5.50	140.00	144.00	11.00
W12 1401101	140.00	152.00	8.20	5.50	145.00	149.00	11.00
W12 1501101	150.00	162.00	8.20	5.50	155.00	159.00	11.00
W12 1601101	160.00	172.00	8.20	5.50	165.00	169.00	11.00
W12 1701101	170.00	182.00	8.20	5.50	175.00	179.00	11.00
W12 1801101	180.00	192.00	8.20	5.50	185.00	189.00	11.00
W12 1901101	190.00	202.00	8.20	5.50	195.00	199.00	11.00
W12 2001101	200.00	212.00	8.20	5.50	205.00	209.00	11.00
W12 2201101	220.00	235.00	9.50	6.70	227.00	232.60	13.00

## HEAVY DUTY WIPER SEAL

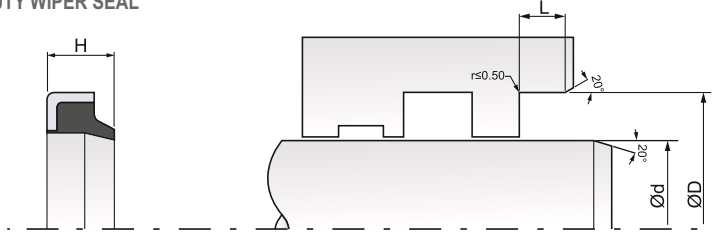

**MATERIAL :** NBR 85/ 90 Shore A ' '

**MAX OPERATING CONDITIONS :**

Temp.    -30°C to +100 °C      Speed    1.0 mtr./sec.

Max Spare Part No.	d (f8)	D (H9)	L (+0.2)	H	Max Spare Part No.	d (f8)	D (H9)	L (+0.2)	H
W14 0061101	6.00	13.00	3.00	4.50	W14 0451103	45.00	60.00	7.00	10.00
W14 0101101	10.00	16.00	3.00	4.50	W14 0501103	50.00	60.00	7.00	10.00
W14 0121101	12.00	18.00	3.50	5.00	W14 0551102	55.00	65.00	7.00	10.00
W14 0121102	12.00	20.00	4.00	6.00	W14 0561102	56.00	66.00	7.00	10.00
W14 0141101	14.00	22.00	3.00	4.00	W14 0601102	60.00	70.00	7.00	10.00
W14 0161101	16.00	22.00	3.00	4.00	W14 0631105	63.00	73.00	7.00	10.00
W14 0161103	16.00	26.00	5.00	8.00	W14 0631101	63.00	75.00	7.00	10.00
W14 0181102	18.00	28.00	7.00	10.00	W14 0651101	65.00	75.00	7.00	10.00
W140190802	19.05	25.00	5.00	7.00	W14 0701101	70.00	80.00	7.00	10.00
W14 0190801	19.05	28.00	5.00	8.00	W14 0751101	75.00	85.00	7.00	10.00
W14 0201102	20.00	28.00	3.50	5.00	W14 0801101	80.00	90.00	7.00	10.00
W14 0201114	20.00	28.00	5.00	7.00	W14 0851101	85.00	95.00	7.00	10.00
W14 0201103	20.00	28.00	5.00	8.00	W14 0901101	90.00	100.00	7.00	10.00
W14 0201105	20.00	30.00	7.00	10.00	W14 0901102	90.00	110.00	7.00	10.00
W14 0221101	22.00	28.00	5.00	8.00	W14 0951101	95.00	105.00	7.00	10.00
W14 0221102	22.00	32.00	7.00	10.00	W14 1001101	100.00	110.00	7.00	10.00
W14 0251122	25.00	33.00	3.00	5.00	W14 1051101	105.00	115.00	7.00	10.00
W14 0251102	25.00	35.00	5.00	7.00	W14 1101101	110.00	120.00	7.00	10.00
W14 0251101	25.00	35.00	7.00	10.00	W14 1151101	115.00	125.00	7.00	10.00
W14 0250801	25.40	36.00	5.00	8.00	W14 1201101	120.00	130.00	7.00	10.00
W14 0301102	30.00	40.00	5.00	8.00	W14 1251101	125.00	140.00	9.00	12.00
W14 0301101	30.00	40.00	7.00	10.00	W14 1301101	130.00	145.00	9.00	12.00
W140301119	30.00	42.00	7.00	10.00	W14 1401101	140.00	155.00	9.00	12.00
W14 0321104	32.00	45.00	7.00	10.00	W14 1501101	150.00	165.00	9.00	12.00
W14 0351102	35.00	45.00	7.00	10.00	W14 1601101	160.00	175.00	9.00	12.00
W14 0361101	36.00	45.00	7.00	10.00	W14 1701102	170.00	185.00	10.00	14.00
W14 0361106	36.00	48.00	5.00	8.00	W14 1781002	178.61	193.50	8.00	11.00
W14 0401102	40.00	50.00	5.00	8.00	W14 1801101	180.00	195.00	10.00	14.00
W14 0401103	40.00	50.00	7.00	10.00	W14 2001102	200.00	220.00	12.00	16.00
W14 0451101	45.00	55.00	7.00	10.00	W14 2401101	240.00	260.00	12.00	16.00

## MEDIUM DUTY WIPER SEAL

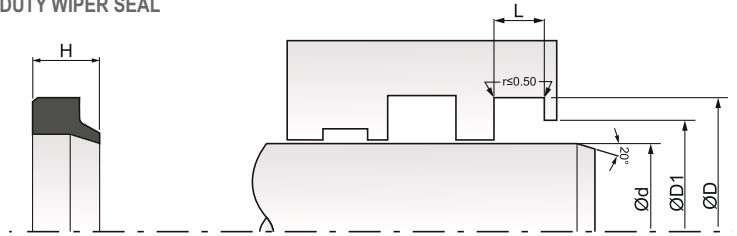

**MATERIAL :** NBR85/ 90 Shore A ' '

**MAX OPERATING CONDITIONS :**

Temp.	-30°C to +100 °C	Speed	1.0 mtr./sec.
-------	------------------	-------	---------------

Max Spare Part No.	d (f8)	D (H9)	L (+0.2)	D1 (H9)	H
W10 0121106	12.00	17.00	3.00	14.00	5.00
W10 0161103	16.00	24.60	5.30	19.00	7.00
W10 0181102	18.00	26.60	5.30	21.00	7.00
W10 0201125	20.00	24.00	2.90	22.00	3.90
W10 0201109	20.00	28.00	5.30	24.00	7.50
W10 0201102	20.00	28.60	5.30	23.00	7.00
W10 0221108	22.00	30.60	5.30	25.00	7.00
W10 0221106	22.00	32.00	5.30	25.00	7.00
W10 0221107	22.00	33.00	4.70	25.00	6.00
W10 0251101	25.00	33.00	4.30	26.00	6.00
W10 0251104	25.00	33.60	5.30	29.00	7.00
W10 0251108	25.00	35.00	7.00	30.00	10.00
W10 0281105	28.00	36.00	5.30	31.00	7.00
W10 0301112	30.00	38.00	5.30	33.00	7.00
W10 0321101	32.00	40.00	5.30	36.00	7.00
W10 0351103	35.00	43.00	5.30	38.00	7.00
W10 0351108	35.00	45.00	5.30	40.00	7.00
W10 0351109	35.00	44.00	5.30	39.60	8.00
W10 0361111	36.00	43.00	4.20	39.60	7.00
W10 0361103	36.00	44.00	5.30	40.00	7.00
W10 0361105	36.00	45.00	5.30	39.00	7.00
W10 0361109	36.00	46.00	7.30	41.00	10.00
W10 0401110	40.00	48.00	5.30	44.00	7.00
W10 0401104	40.00	48.60	5.30	43.00	7.00
W10 0401113	40.00	50.00	5.00	45.00	7.00
W10 0401109	40.00	50.00	5.00	45.00	8.00
W10 0401108	40.00	52.00	5.00	46.00	7.00
W10 0421104	42.00	50.00	5.30	46.00	7.00
W10 0451101	45.00	55.00	5.30	48.00	7.00
W10 0501104	50.00	58.00	5.30	54.00	7.00
W10 0501107	50.00	58.60	5.30	53.00	7.00
W10 0501110	50.00	60.00	5.00	55.00	7.00

## MEDIUM DUTY WIPER SEAL

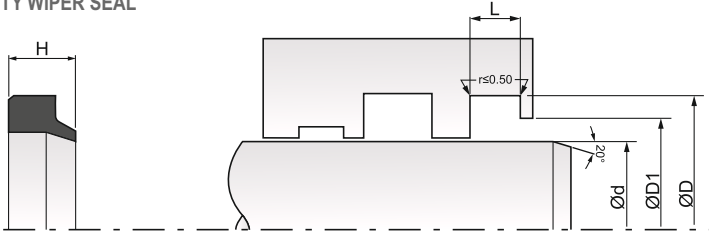

Max Spare Part No.	d (f8)	D (H9)	L (+0.2)	D1 (H9)	H
W10 0501113	50.00	60.00	5.30	55.00	8.00
W10 0501112	50.00	60.00	7.00	55.00	10.00
W10 0551103	55.00	65.00	5.30	60.00	7.00
W10 0561103	56.00	66.00	5.30	61.00	7.00
W10 0561107	56.00	66.60	5.30	59.00	7.00
W10 0601103	60.00	68.00	5.30	63.00	7.00
W10 0601114	60.00	70.00	5.30	65.00	7.00
W10 0631102	63.00	73.00	5.30	66.00	7.00
W10 0631107	63.00	73.00	6.30	68.00	10.00
W10 0651101	65.00	75.00	5.30	68.00	7.00
W10 0701103	70.00	80.00	5.30	75.00	7.00
W10 0701123	70.00	80.00	6.00	75.00	8.00
W10 0701101	70.00	80.00	7.00	75.00	10.00
W10 0701104	70.00	80.60	5.30	73.00	7.00
W10 0751104	75.00	83.60	5.30	78.00	7.00
W10 0751101	75.00	87.20	7.10	81.00	12.00
W10 0801129	80.00	88.60	5.30	83.00	7.00
W10 0801132	80.00	90.00	5.00	85.00	7.00
W10 0801110	80.00	90.00	7.30	85.00	10.00
W10 0801108	80.00	92.20	7.20	86.00	12.00
W10 0851105	85.00	95.60	7.20	91.00	12.00
W10 0901114	90.00	100.20	7.10	94.00	12.00
W10 0901115	90.00	107.00	7.10	96.00	12.20
W10 0901101	90.00	102.20	7.20	96.00	12.00
W10 0901113	90.00	105.00	7.00	97.00	10.00
W10 0951104	95.00	108.00	5.30	101.50	10.00
W10 0981102	98.43	107.95	3.00	102.71	5.00
W10 1001103	100.00	110.00	5.00	105.00	7.00
W10 1001101	100.00	112.20	7.20	106.00	12.00
W10 1101101	110.00	122.20	7.20	116.00	12.00
W10 1151101	115.00	127.00	7.00	120.40	12.00
W10 1201103	120.00	130.60	5.30	125.00	7.00
W10 1201101	120.00	132.20	7.10	126.00	12.00
W10 1251106	125.00	137.00	7.10	131.00	12.00
W10 1251103	125.00	140.00	10.20	132.50	16.00
W10 1301101	130.00	142.00	7.00	136.20	10.00

## MEDIUM DUTY WIPER SEAL

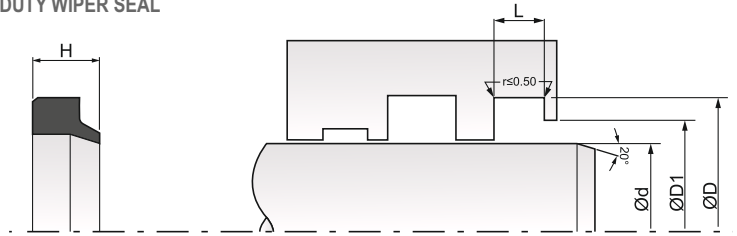

Max Spare Part No.	d (f8)	D (H9)	L (+0.2)	D1 (H9)	H
W10 1321101	132.86	152.40	7.94	140.00	15.87
W10 1351105	135.00	147.00	7.00	141.00	12.00
W10 1401106	140.00	150.00	5.30	144.00	7.00
W10 1401101	140.00	155.00	10.00	147.50	16.00
W10 1501107	150.00	162.00	7.10	156.00	8.20
W10 1501101	150.00	165.00	10.20	157.60	16.00
W10 1551103	155.00	169.20	7.10	156.00	12.00
W10 1601108	160.00	175.00	10.10	168.00	12.00
W10 1601105	160.00	175.00	10.20	167.60	16.00
W10 1701101	170.00	182.00	7.00	176.00	12.00
W10 1801103	180.00	200.00	10.20	190.00	18.00
W10 1901102	190.00	210.00	10.30	200.00	18.00
W10 2001101	200.00	220.00	10.20	210.00	18.00
W10 2501101	250.00	270.00	10.00	260.00	18.00
W10 4001101	400.00	420.00	10.00	410.00	18.00

## HEAVY DUTY WIPER SEAL

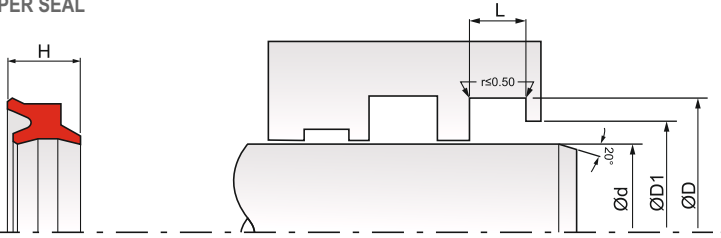

**MATERIAL :** Polyurethane 92Shore A '

**MAX OPERATING CONDITIONS :**

Temp.    -30°C to +100 °C      Speed    1.0 mtr./sec.

Max Spare Part No.	d (f8)	D (H9)	L (+0.2)	H	D1 (H9)	Max Spare Part No.	d (f8)	D (H9)	L (+0.2)	H	D1 (H9)
W13 010L516	10.00	14.00	2.50	3.50	11.50	W13 040L502	40.00	48.00	5.00	6.50	43.00
W13 010L503	10.00	14.00	3.00	4.00	11.50	W13 045L502	45.00	53.00	5.00	6.50	48.00
W13 010L501	10.00	16.00	3.60	4.80	10.50	W13 045L505	45.00	53.00	5.00	7.00	48.00
W13 012L514	12.00	16.50	3.30	4.00	13.50	W13 050L501	50.00	58.00	5.00	6.50	53.00
W13 012L502	12.00	18.00	4.50	7.00	14.50	W13 055L501	55.00	63.00	5.00	6.50	58.00
W13 016L513	16.00	20.00	3.00	4.00	17.50	W13 056L501	56.00	66.00	5.00	7.00	59.00
W13 016L523	16.00	23.00	3.00	5.00	19.00	W13 060L501	60.00	68.00	5.00	6.50	63.00
W13 016L501	16.00	24.00	4.50	6.00	19.00	W13 060L502	60.00	70.00	6.00	6.80	63.00
W13 018L503	18.00	26.00	5.00	7.00	21.00	W13 063L501	63.00	71.00	5.00	6.50	66.00
W13 018L501	18.00	26.00	4.50	6.00	21.00	W13 070L508	70.00	80.00	5.00	7.00	73.00
W13 020L505	20.00	28.00	4.50	6.00	23.00	W13 070L501	70.00	80.00	6.00	8.00	73.00
W13 020L503	20.00	28.00	5.00	7.00	23.00	W13 080L507	80.00	90.00	6.00	8.00	83.00
W13 022L503	22.40	30.40	4.50	6.00	25.00	W13 085L501	85.00	95.00	6.00	8.00	88.00
W13 025L503	25.00	33.00	4.50	6.00	28.00	W13 090L503	90.00	100.00	6.00	8.00	93.00
W13 025L501	25.00	33.00	5.00	7.00	28.00	W13 100L503	100.00	110.00	6.00	8.00	103.00
W13 028L501	28.00	35.00	4.50	6.00	31.00	W13 110L501	110.00	125.00	8.00	11.00	114.00
W13 028L502	28.00	36.00	4.50	6.00	31.00	W13 120L502	120.00	135.00	8.00	11.00	124.00
W13 028L503	28.00	36.00	5.00	7.00	31.00	W13 136L501	136.00	146.00	5.50	8.35	139.00
W13 030L501	30.00	38.00	5.00	6.50	33.00	W13 140L502	140.00	155.00	8.50	9.50	144.00
W13 031L501	31.50	39.50	5.00	6.50	34.50	W13 150L503	150.00	165.00	8.00	11.00	154.00
W13 032L505	32.00	40.00	4.50	5.80	35.00	W13 155L501	155.00	165.00	5.50	8.35	158.00
W13 032L501	32.00	40.00	5.00	6.50	35.00	W13 160L502	160.00	175.00	8.00	11.00	164.00
W13 035L501	35.00	43.00	5.00	6.50	38.00	W13 176L501	176.00	186.00	5.50	8.35	179.00
W13 036L501	36.00	44.00	5.00	7.00	39.00	W13 180L501	180.00	195.00	8.00	11.00	184.00
W13 038L501	38.00	46.00	5.00	7.00	41.00	W13 200L502	200.00	214.00	7.00	9.50	204.00



## MEDIUM DUTY WIPER SEAL

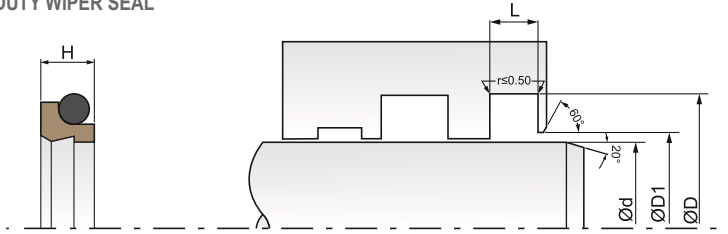

**MATERIAL:** O'Ring : NBR 70/75 Shore 'A'.  
Sealing Ring : BFT (Bronze Filled PTFE)

### MAX OPERATING CONDITIONS :

Temp. -30°C to +100 °C      Speed 10.0 mtr./sec.

Max Spare Part No.	d (f8)	D (H9)	D1 (H9)	L (+0.2)
W380257001	25.00	31.80	26.50	5.00
W380360801	36.00	42.80	37.50	5.00
W380360802	36.00	43.60	37.50	4.20
W380400801	40.00	46.80	41.50	5.00
W380400802	40.00	48.80	41.50	6.00
W380450808	45.00	51.80	46.50	5.00
W380450804	45.00	53.80	46.50	6.00
W380560802	56.00	64.80	57.50	6.00
W380630801	63.00	69.80	64.50	5.00
W380650801	65.00	73.80	66.50	6.00
W380700803	70.00	78.80	71.50	6.00
W380700802	70.00	82.20	71.50	8.10
W380800801	80.00	88.80	81.50	6.00
W380900801	90.00	98.80	91.50	6.00
W380957003	95.00	107.20	96.50	8.40
W381000801	100.00	108.80	101.50	6.00
W381000802	100.00	112.20	101.50	8.10
W381100801	110.00	118.80	111.50	6.00
W381130803	113.00	121.80	114.50	6.00
W381150801	115.00	123.80	116.50	6.00
W381150803	115.00	127.20	116.50	8.10
W381330801	133.00	145.20	134.50	8.10
W381330802	133.00	141.80	134.50	6.00
W381400801	140.00	148.80	141.50	6.00
W381500801	150.00	158.80	151.50	6.00
W381800802	180.00	188.80	181.50	6.00

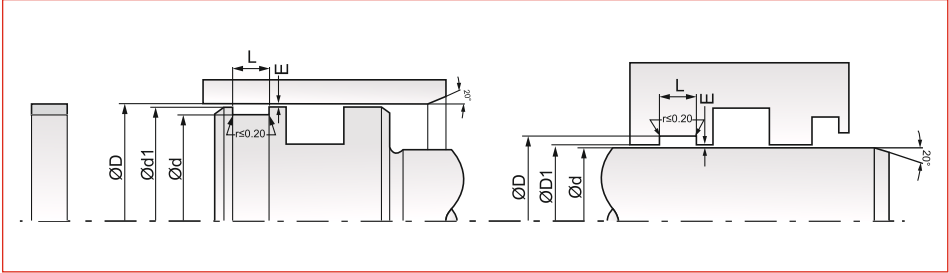

**MATERIAL :** Bronze filled Teflon (BFT)

**MAX OPERATING CONDITIONS :**

Temp. : -200°C to +260°C  
 Speed : 15.0 m/s

**COMPRESSIVE STRENGTH AT YIELD :**

Max 15 N/mm<sup>2</sup> (+25°C)  
 Max 12 N/mm<sup>2</sup> (+80°C)  
 Max 8 N/mm<sup>2</sup> (+120°C)

Max Spare Part No.	C/S (mm)	L (mm)
GS0017009	1.50	4.00
GS0017011	1.50	5.60
GS0087001	2.00	8.00
GS0027031	2.00	10.00
GS0027025	2.00	15.00
GS0027036	2.00	20.00
GS0027001	2.50	5.60
GS0027006	2.50	6.00
GS0027017	2.50	8.00
GS0027002	2.50	9.70
GS0027007	2.50	10.00
GS0027013	2.50	12.00
GS0027003	2.50	15.00
GS0027027	2.50	20.00
GS0027005	2.50	25.00
GS0037010	3.00	20.00
GS0037001	3.17	9.50
GS0037020	3.17	12.70
GS0037002	3.17	15.80
GS0037011	3.17	25.40

**MATERIAL :** Polyester Resin Fabric (PRW)

**MAX OPERATING CONDITIONS :**

Temp. : -40°C to +120°C  
 Speed : 5.0 m/s

**COMPRESSIVE STRENGTH AT YIELD :**

Max 110 N/mm<sup>2</sup> (+25°C)  
 Max 55 N/mm<sup>2</sup> (+80°C)

Max Spare Part No.	C/S (mm)	L (mm)
GS002N604	2.5	5.6
GS002N601	2.5	9.7
GS002N602	2.5	15.0
GS002N605	2.5	20.0
GS002N603	2.5	25.0
GS003N609	3.17	9.52
GS003N608	3.17	12.70
GS003N607	3.17	15.87
GS003N606	3.17	19.05
GS003N605	3.17	25.40
GS004N601	4.00	20.00
GS004N602	4.00	25.00
GS004N603	4.00	30.00
GS004N604	4.00	40.00

• ØD & Ød are as per Customer requirement

## LIGHT DUTY PISTON SEAL

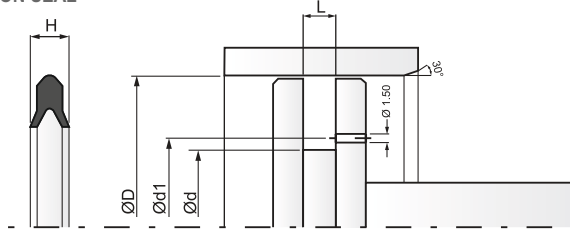

**MATERIAL :** NBR 70/75 Shore 'A'.

**MAX OPERATING CONDITIONS :**

Temp. -30°C to +100 °C

Pressure 16 BAR

Speed 1.0 mtr./sec.

Max Spare Part No.	D (H9)	d (h9)	d1 (h9)	L (+0.2)	Seal Ht.
P270090901	20.00	9.50	11.20	2.30	3.00
P270101001	20.00	10.00	11.50	2.30	2.80
P270150904	25.00	15.00	17.40	2.10	2.50
P270250905	35.00	21.50	23.20	3.00	3.50
P270490901	63.00	49.00	51.00	4.00	3.50
P270371001	50.00	35.00	37.50	3.00	2.50
P270630902	80.00	60.00	63.00	4.10	3.50
P271320902	160.00	132.00	138.90	6.20	7.70
P271350901	160.00	132.00	139.00	6.20	6.70
P271570901	190.00	157.00	161.50	6.20	9.50
P271680901	200.00	168.00	170.00	8.50	9.30
P271891001	225.00	189.50	192.00	8.50	10.30
P272130901	250.00	213.00	216.00	9.00	11.00

## DOUBLE ACTING WIPER SEAL

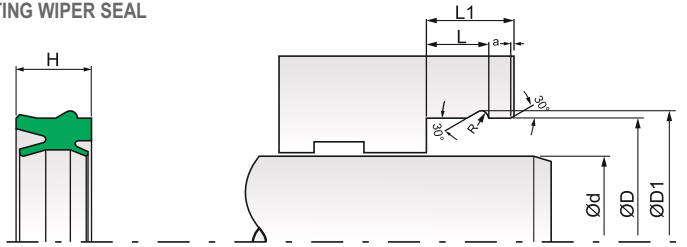

**MATERIAL :** Polyurethane 90 Shore 'A'.

### MAX OPERATING CONDITIONS :

Temp.	-30°C to +100 °C	Pressure	16 BAR	Speed	1.0 mtr./sec.
-------	------------------	----------	--------	-------	---------------

Max Spare Part No.	d (f8)	D (H9)	L1 (+0.2)	L (+0.2)	H	D1 (H9)
W07012L502	12.00	22.00	13.00	8.80	10.70	24.00
W07014L502	14.00	24.00	13.00	8.80	10.70	26.00
W07016L501	16.00	26.00	13.00	8.80	10.70	28.00
W07018L503	18.00	28.00	13.00	8.80	10.70	30.00
W07020L501	20.00	30.00	13.00	8.80	10.70	32.00
W07022L503	22.00	32.00	13.00	8.80	10.70	34.00
W07025L502	25.00	35.00	13.00	8.80	10.70	37.00
W07030L503	30.00	40.00	13.00	8.80	10.70	42.00
W07032L504	32.00	42.00	13.00	8.80	10.70	44.00
W07040L501	40.00	50.00	13.00	8.80	10.70	52.00
W07045L501	45.00	55.00	13.00	8.80	10.70	57.00

## MEDIUM DUTY CUSHION SEAL

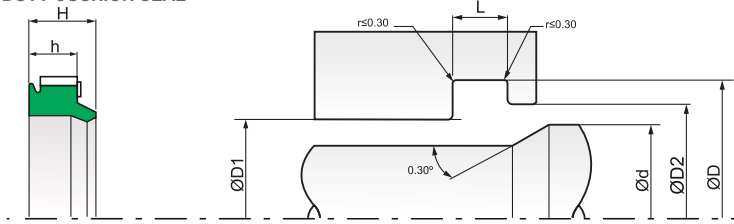

**MATERIAL :** Polyurethane 90° Shore 'A'.

### MAX OPERATING CONDITIONS :

Temp.	-30°C to +100 °C	Pressure	16 BAR	Speed	1.0 mtr./sec.
-------	------------------	----------	--------	-------	---------------

Max Spare Part No.	d (f8)	D (H9)	L (+0.2)	h	H	D2 (H9)	D1 (H9)
S09016L501	16.00	24.00	7.00	6.20	7.80	21.00	17.00
S09018L501	18.00	26.00	7.00	6.20	7.80	23.00	19.00
S09020L501	20.00	28.00	7.00	6.50	7.80	24.00	21.00
S09022L501	22.00	30.00	7.00	6.50	7.80	26.00	23.00
S09025L502	25.00	33.00	7.00	6.50	7.80	29.00	26.00
S09028L501	28.00	36.00	7.00	6.50	7.80	32.00	29.00
S09030L502	30.00	40.00	7.00	6.50	7.80	35.00	31.50
S09032L501	32.00	42.00	7.00	6.50	7.80	37.00	33.50
S09036L501	36.00	46.00	7.00	6.50	7.80	41.00	37.50
S09040L501	40.00	50.00	7.00	6.50	7.80	45.00	41.50
S09045L502	45.00	55.00	7.00	6.50	7.80	50.00	46.50
S09050L502	50.00	60.00	7.00	6.50	7.80	55.00	51.50



**R01**

The **R01** type rotary shaft seal has a metal inserts (Bonded) encased in rubber.



**R15**

The **R15** type rotary shaft seal has a metal encased on the outer diameter.



**R02**

The **R02** type rotary shaft seal is similar to R01 type but with an additional dust lip.

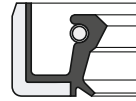

**R17**

The **R17** type rotary shaft seal is similar to R15 type but with an additional dust lip.

Max Spare Part No.	Shaft Dia.	Hsg. Dia.	Seal Ht.	Max Spare Part No.	Shaft Dia.	Hsg. Dia.	Seal Ht.
R010060813	6.00	16.00	6.00	R010110803	11.00	22.00	7.00
R010060801	6.00	16.00	7.00	R010110827	11.00	26.00	7.00
R010060806	6.00	19.00	7.00	R010120814	12.00	18.00	5.00
R010060805	6.00	22.00	7.00	R010120809	12.00	19.00	5.00
R010070814	7.00	16.00	6.00	R010120801	12.00	20.00	5.00
R010070807	7.00	16.00	7.00	R020120872	12.00	20.00	5.00
R010070803	7.00	22.00	7.00	R010120817	12.00	20.00	7.00
R010080803	8.00	18.00	7.00	R0101208B2	12.00	20.00	8.00
R010080830	8.00	19.00	7.00	R0101208C6	12.00	21.00	7.00
R010080813	8.00	19.00	8.00	R010120901	12.00	22.00	4.00
R010080821	8.00	20.00	7.00	R010120898	12.00	22.00	5.00
R010080812	8.00	22.00	7.00	R010120813	12.00	22.00	6.00
R010080801	8.00	22.00	8.00	R010120838	12.00	22.00	7.00
R010080824	8.00	24.00	7.00	R020120801	12.00	22.00	7.00
R010090848	9.00	16.00	6.00	R150120801	12.00	22.00	7.00
R010090844	9.00	19.00	6.00	R010120848	12.00	22.00	8.00
R010090832	9.00	20.00	7.00	R0101208B3	12.00	22.00	9.00
R010090806	9.00	22.00	7.00	R010120818	12.00	24.00	6.00
R010090833	9.00	22.00	8.00	R010120832	12.00	24.00	7.00
R010090834	9.00	24.00	7.00	R0101208A7	12.00	25.00	6.00
R010090835	9.00	26.00	7.00	R0101208C9	12.00	25.00	7.00
R010100809	10.00	19.00	6.00	R020120803	12.00	25.00	7.00
R010100824	10.00	19.00	7.00	R010120836	12.00	25.00	8.00
R010100812	10.00	20.00	6.00	R010120815	12.00	26.00	7.00
R010100805	10.00	20.00	7.00	R010120808	12.00	26.00	8.00
R010100816	10.00	22.00	7.00	R0101208B5	12.00	27.00	7.00
R010100815	10.00	22.00	8.00	R020120880	12.00	28.00	5.00
R010100840	10.00	24.00	6.00	R010120802	12.00	28.00	7.00
R010100813	10.00	24.00	7.00	R020120820	12.00	28.00	7.00
R010100849	10.00	25.00	6.00	R0101208B6	12.00	28.00	8.00
R010100850	10.00	25.00	7.00	R150120843	12.00	29.00	7.00
R010100814	10.00	26.00	7.00	R010120888	12.00	30.00	7.00
R020100803	10.00	26.00	7.00	R0101208A8	12.00	30.00	10.00
R010100823	10.00	28.00	8.00	R010120821	12.00	32.00	7.00
R010100843	10.00	30.00	7.00	R0101208B7	12.00	32.00	8.00
R010100845	10.00	30.00	10.00	R0101208A2	12.00	35.00	7.00
R010100846	10.00	32.00	8.00	R010120857	12.70	21.44	6.35



**R01**

The **R01** type rotary shaft seal has a metal inserts (Bonded) encased in rubber.



**R15**

The **R15** type rotary shaft seal has a metal encased on the outer diameter.



**R02**

The **R02** type rotary shaft seal is similar to R01 type but with an additional dust lip.

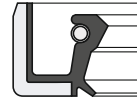

**R17**

The **R17** type rotary shaft seal is similar to R15 type but with an additional dust lip.

Max Spare Part No.	Shaft Dia.	Hsg. Dia.	Seal Ht.	Max Spare Part No.	Shaft Dia.	Hsg. Dia.	Seal Ht.
R010120881	12.70	25.40	6.35	R020150801	15.00	24.00	7.00
R0101208B9	12.70	25.40	7.87	R150150803	15.00	24.00	7.00
R010120869	12.70	25.40	9.52	R010150865	15.00	25.00	5.00
R010120854	12.70	28.57	6.35	R010150817	15.00	25.00	7.00
R0101208C1	12.70	28.57	7.87	R0101508A2	15.00	25.00	8.00
R0101208C2	12.70	28.57	9.52	R010150811	15.00	26.00	7.00
R010130826	13.00	22.00	5.00	R020150806	15.00	26.00	7.00
R010130816	13.00	22.00	7.00	R010150819	15.00	27.00	7.00
R010130831	13.00	24.00	7.00	R010150882	15.00	28.00	6.00
R010130827	13.00	25.00	7.00	R010150820	15.00	28.00	7.00
R010130813	13.00	26.00	7.00	R020150836	15.00	28.00	7.00
R010130817	13.00	28.00	7.00	R010150868	15.00	30.00	5.00
R010130828	13.00	30.00	7.00	R010150821	15.00	30.00	6.00
R010130834	13.00	32.00	8.00	R010150802	15.00	30.00	7.00
R010140805	14.00	22.00	4.00	R020150804	15.00	30.00	7.00
R010140814	14.00	22.00	7.00	R010150822	15.00	30.00	8.00
R020140805	14.00	22.00	7.00	R010150823	15.00	30.00	10.00
R010140851	14.00	24.00	5.00	R010150824	15.00	32.00	7.00
R010140822	14.00	24.00	7.00	R020150821	15.00	32.00	7.00
R020140817	14.00	24.00	7.00	R010150890	15.00	32.00	10.00
R010140817	14.00	25.00	7.00	R0101508B6	15.00	35.00	6.00
R010140829	14.00	26.00	7.00	R010150813	15.00	35.00	7.00
R010140820	14.00	27.00	7.00	R020150829	15.00	35.00	7.00
R010140802	14.00	28.00	7.00	R010150812	15.00	35.00	8.00
R020140812	14.00	28.00	7.00	R010150860	15.00	35.00	10.00
R010140810	14.00	28.00	8.00	R0101508A3	15.00	38.00	8.00
R010140818	14.00	30.00	7.00	R0101508B5	15.00	42.00	8.00
R010140815	14.00	30.00	10.00	R0101508A9	15.00	42.00	10.00
R010140816	14.00	32.00	7.00	R020150831	15.87	25.40	6.50
R010140852	14.00	32.00	10.00	R010150841	15.87	28.57	6.35
R010140837	14.00	35.00	7.00	R010150891	15.87	28.57	8.00
R0101508A4	15.00	22.00	5.00	R010150892	15.87	28.57	9.52
R010150876	15.00	22.00	7.00	R040160807	16.00	22.00	4.00
R010150814	15.00	24.00	5.00	R010160806	16.00	22.00	5.00
R020150802	15.00	24.00	5.00	R010160873	16.00	24.00	5.00
R010150804	15.00	24.00	6.00	R020160829	16.00	24.00	5.00
R010150815	15.00	24.00	7.00	R010160856	16.00	24.00	7.00



**R01**

The **R01** type rotary shaft seal has a metal inserts (Bonded) encased in rubber.



**R15**

The **R15** type rotary shaft seal has a metal encased on the outer diameter.



**R02**

The **R02** type rotary shaft seal is similar to R01 type but with an additional dust lip.

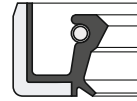

**R17**

The **R17** type rotary shaft seal is similar to R15 type but with an additional dust lip.

Max Spare Part No.	Shaft Dia.	Hsg. Dia.	Seal Ht.	Max Spare Part No.	Shaft Dia.	Hsg. Dia.	Seal Ht.
R010160825	16.00	25.00	7.00	R010170882	17.00	30.00	10.00
R010160874	16.00	26.00	5.00	R010170883	17.00	31.00	7.00
R010160821	16.00	26.00	7.00	R010170846	17.00	32.00	7.00
R010160829	16.00	26.00	8.00	R020170802	17.00	32.00	7.00
R010160819	16.00	28.00	6.00	R010170860	17.00	32.00	8.00
R010160836	16.00	28.00	7.00	R010170823	17.00	32.00	10.00
R020160804	16.00	28.00	7.00	R010170835	17.00	35.00	7.00
R170160802	16.00	28.00	7.00	R010170861	17.00	35.00	8.00
R010160838	16.00	28.00	10.00	R010170820	17.00	35.00	10.00
R010160869	16.00	29.00	10.00	R020170811	17.00	35.00	10.00
R010160868	16.00	30.00	4.50	R010170815	17.00	38.00	8.00
R010160804	16.00	30.00	5.00	R010170863	17.00	40.00	6.00
R010160853	16.00	30.00	6.00	R010170813	17.00	40.00	7.00
R010160802	16.00	30.00	7.00	R010170841	17.00	40.00	10.00
R010160817	16.00	30.00	10.00	R010170866	17.00	42.00	10.00
R010160841	16.00	32.00	7.00	R010170868	17.00	45.00	10.00
R020160826	16.00	32.00	7.00	R010170805	17.00	47.00	7.00
R010160842	16.00	32.00	10.00	R010170878	17.00	47.00	7.50
R010160812	16.00	35.00	7.00	R010170870	17.00	47.00	10.00
R020160815	16.00	35.00	7.00	R0101708E6	17.44	30.16	8.13
R010160801	16.00	35.00	10.00	R010180838	18.00	24.00	7.00
R010160859	16.00	40.00	10.00	R010180811	18.00	25.00	5.00
R010170877	17.00	25.00	4.00	R010180853	18.00	26.00	4.00
R010170822	17.00	25.00	7.00	R170180807	18.00	26.50	7.00
R010170829	17.00	26.00	7.00	R010180809	18.00	28.00	7.00
R010170801	17.00	27.00	7.00	R010180858	18.00	30.00	5.00
R010170803	17.00	28.00	6.00	R010180808	18.00	30.00	6.00
R010170810	17.00	28.00	7.00	R010180834	18.00	30.00	7.00
R020170804	17.00	28.00	7.00	R020180813	18.00	30.00	7.00
R150170815	17.00	28.00	7.00	R010180803	18.00	30.00	8.00
R010170806	17.00	30.00	5.00	R010180819	18.00	30.00	10.00
R010170871	17.00	30.00	6.00	R010180820	18.00	32.00	7.00
R010170819	17.00	30.00	7.00	R020180811	18.00	32.00	7.00
R020170808	17.00	30.00	7.00	R010180859	18.00	33.00	6.00
R150170811	17.00	30.00	7.00	R010180836	18.00	35.00	7.00
R010170859	17.00	30.00	8.00	R010180832	18.00	35.00	8.00
R170170806	17.00	30.00	8.00	R010180842	18.00	35.00	10.00



**R01**

The **R01** type rotary shaft seal has a metal inserts (Bonded) encased in rubber.



**R15**

The **R15** type rotary shaft seal has a metal encased on the outer diameter.



**R02**

The **R02** type rotary shaft seal is similar to R01 type but with an additional dust lip.

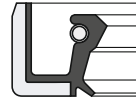

**R17**

The **R17** type rotary shaft seal is similar to R15 type but with an additional dust lip.

Max Spare Part No.	Shaft Dia.	Hsg. Dia.	Seal Ht.	Max Spare Part No.	Shaft Dia.	Hsg. Dia.	Seal Ht.
R010180860	18.00	37.00	8.00	R010190862	19.84	31.75	6.35
R010180844	18.00	38.00	10.00	R0101908A1	19.94	31.75	6.35
R010180833	18.00	40.00	7.00	R040200801	20.00	26.00	4.00
R010180847	18.00	40.00	10.00	R010200851	20.00	28.00	4.00
R010180850	18.00	42.00	10.00	R010200830	20.00	28.00	5.00
R010180861	18.00	47.00	7.00	R0102008A6	20.00	28.00	6.00
R010180855	18.00	47.00	10.00	R010200850	20.00	28.00	8.00
R010190802	19.00	26.00	5.00	R0102008A1	20.00	30.00	5.00
R010190812	19.00	27.00	6.00	R020200811	20.00	30.00	5.00
R0101908B2	19.00	30.00	5.00	R010200890	20.00	30.00	6.00
R010190885	19.00	30.00	7.00	R020200824	20.00	30.00	6.00
R020190815	19.00	30.00	7.00	R170200802	20.00	30.00	6.00
R010190829	19.00	30.00	8.00	R010200838	20.00	30.00	7.00
R010190875	19.00	32.00	7.00	R020200813	20.00	30.00	7.00
R020190818	19.00	32.00	7.00	R150200809	20.00	30.00	7.00
R010190822	19.00	32.00	10.00	R0102008A9	20.00	30.00	8.00
R0101908B3	19.00	33.00	7.00	R010200820	20.00	30.00	10.00
R0101908F1	19.00	35.00	6.50	R010200810	20.00	32.00	5.00
R010190809	19.00	35.00	7.00	R010200878	20.00	32.00	6.00
R010190804	19.00	35.00	8.00	R010200807	20.00	32.00	7.00
R010190815	19.00	35.00	10.00	R020200801	20.00	32.00	7.00
R010190893	19.00	38.00	7.00	R150200813	20.00	32.00	7.00
R010190826	19.00	38.00	10.00	R010200872	20.00	32.00	8.00
R0101908E1	19.00	40.00	7.00	R010200863	20.00	32.00	10.00
R010190823	19.00	40.00	10.00	R010200862	20.00	33.00	7.00
R0101908B4	19.00	41.00	10.00	R010200823	20.00	35.00	6.00
R010190899	19.00	47.00	10.00	R010200806	20.00	35.00	7.00
R0101908B5	19.05	28.57	6.35	R020200803	20.00	35.00	7.00
R010190845	19.05	31.75	6.35	R150200801	20.00	35.00	7.00
R020190832	19.05	31.75	6.35	R010200847	20.00	35.00	8.00
R0101908B6	19.05	31.75	9.40	R020200837	20.00	35.00	8.00
R0101908A2	19.05	33.40	6.35	R010200836	20.00	35.00	10.00
R0101908A3	19.05	34.92	6.35	R0102008A3	20.00	36.00	7.00
R0101908A4	19.05	34.92	9.52	R0102008B3	20.00	36.00	10.00
R010190880	19.05	38.10	9.52	R010200856	20.00	37.00	7.00
R020190823	19.05	38.10	9.52	R010200886	20.00	37.00	8.00
R0101908A5	19.05	41.27	9.52	R0102008A8	20.00	37.00	10.00

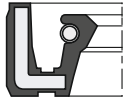

**R01**

The **R01** type rotary shaft seal has a metal inserts (Bonded) encased in rubber.

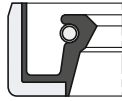

**R15**

The **R15** type rotary shaft seal has a metal encased on the outer diameter.



**R02**

The **R02** type rotary shaft seal is similar to R01 type but with an additional dust lip.

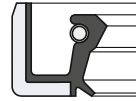

**R17**

The **R17** type rotary shaft seal is similar to R15 type but with an additional dust lip.

Max Spare Part No.	Shaft Dia.	Hsg. Dia.	Seal Ht.	Max Spare Part No.	Shaft Dia.	Hsg. Dia.	Seal Ht.
R010200837	20.00	38.00	7.00	R010210818	21.00	41.00	10.00
R010200887	20.00	38.00	8.00	R010210819	21.00	42.00	6.00
R010200892	20.00	38.00	10.00	R010210820	21.00	42.00	7.00
R0102008Q0	20.00	40.00	5.00	R010220837	22.00	30.00	7.00
R020200858	20.00	40.00	5.00	R0102208A5	22.00	32.00	4.00
R010200808	20.00	40.00	7.00	R010220820	22.00	32.00	5.00
R020200819	20.00	40.00	7.00	R010220855	22.00	32.00	5.50
R010200891	20.00	40.00	8.00	R010220817	22.00	32.00	6.00
R0102008A7	20.00	40.00	9.00	R010220810	22.00	32.00	7.00
R010200882	20.00	40.00	10.00	R020220801	22.00	32.00	7.00
R020200829	20.00	40.00	10.00	R010220866	22.00	32.00	8.00
R010200804	20.00	42.00	7.00	R010220818	22.00	32.00	10.00
R020200902	20.00	42.00	7.00	R0102208B8	22.00	33.00	6.00
R150200824	20.00	42.00	7.00	R010220823	22.00	33.00	7.00
R010200896	20.00	42.00	8.00	R010220808	22.00	35.00	6.00
R020200821	20.00	42.00	8.00	R010220801	22.00	35.00	7.00
R010200822	20.00	42.00	10.00	R020220806	22.00	35.00	7.00
R010200834	20.00	45.00	8.00	R150220824	22.00	35.00	7.00
R010200865	20.00	45.00	10.00	R010220828	22.00	35.00	8.00
R010200897	20.00	47.00	6.00	R010220839	22.00	35.00	10.00
R010200805	20.00	47.00	7.00	R010220850	22.00	37.00	8.00
R020200834	20.00	47.00	7.00	R010220824	22.00	38.00	7.00
R010200871	20.00	47.00	8.00	R010220829	22.00	38.00	8.00
R020200802	20.00	47.00	8.00	R150220832	22.00	38.00	9.50
R010200873	20.00	47.00	10.00	R010220858	22.00	38.00	10.00
R170200801	20.00	47.00	10.00	R170220803	22.00	38.00	10.00
R010200860	20.00	48.00	10.00	R010220802	22.00	40.00	7.00
R010200899	20.00	50.00	7.00	R020220805	22.00	40.00	7.00
R0102008A5	20.00	50.00	8.00	R010220852	22.00	40.00	8.00
R010200845	20.00	50.00	10.00	R010220847	22.00	40.00	10.00
R010200841	20.00	52.00	7.00	R010220841	22.00	42.00	7.00
R010200833	20.00	52.00	8.00	R010220842	22.00	42.00	10.00
R010200840	20.00	52.00	10.00	R0102208C2	22.00	42.00	11.00
R010210816	21.00	33.00	7.00	R020220838	22.00	42.00	11.00
R010210804	21.00	35.00	7.00	R010220877	22.00	44.00	10.00
R010210805	21.00	37.00	7.00	R010220861	22.00	45.00	8.00
R010210817	21.00	37.00	10.00	R010220892	22.00	45.00	10.00



**R01**

The **R01** type rotary shaft seal has a metal inserts (Bonded) encased in rubber.



**R15**

The **R15** type rotary shaft seal has a metal encased on the outer diameter.



**R02**

The **R02** type rotary shaft seal is similar to R01 type but with an additional dust lip.

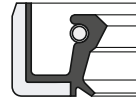

**R17**

The **R17** type rotary shaft seal is similar to R15 type but with an additional dust lip.

Max Spare Part No.	Shaft Dia.	Hsg. Dia.	Seal Ht.	Max Spare Part No.	Shaft Dia.	Hsg. Dia.	Seal Ht.
R010220814	22.00	47.00	7.00	R010240801	24.00	45.00	8.00
R170220801	22.00	47.00	7.00	R010240856	24.00	45.00	10.00
R010220803	22.00	47.00	10.00	R010240806	24.00	47.00	7.00
R010220812	22.00	48.00	10.00	R010240802	24.00	47.00	10.00
R010220827	22.00	50.00	10.00	R010240859	24.00	48.00	8.00
R010220899	22.00	52.00	10.00	R010240861	24.00	50.00	8.00
R01022080H	22.22	38.10	9.52	R010240865	24.00	52.00	8.00
R010230863	23.00	40.00	6.00	R010240821	24.00	52.00	10.00
R010230832	23.00	40.00	8.00	R010240876	24.00	62.00	10.00
R010230835	23.00	40.00	10.00	R010250864	25.00	32.00	4.00
R020230809	23.74	34.93	6.35	R010250823	25.00	32.00	7.00
R010230844	23.75	34.92	6.35	R0102508C3	25.00	33.00	4.00
R010230826	23.81	34.93	6.35	R010250818	25.00	33.00	5.00
R010230830	23.81	38.10	9.52	R01025082R	25.00	33.00	6.00
R010240870	24.00	35.00	6.00	R0102508F1	25.00	33.00	7.00
R010240808	24.00	35.00	7.00	R010250871	25.00	35.00	5.00
R020240807	24.00	35.00	7.00	R010250829	25.00	35.00	6.00
R010240803	24.00	35.00	8.00	R020250822	25.00	35.00	6.00
R010240834	24.00	35.00	10.00	R010250803	25.00	35.00	7.00
R010240891	24.00	36.00	7.00	R020250804	25.00	35.00	7.00
R010240826	24.00	36.00	8.00	R150250801	25.00	35.00	7.00
R010240805	24.00	37.00	7.00	R010250831	25.00	35.00	8.00
R020240883	24.00	37.00	7.00	R0102508B6	25.00	35.00	9.00
R010240866	24.00	38.00	6.00	R010250866	25.00	35.00	10.00
R010240841	24.00	38.00	7.00	R020250834	25.00	35.00	10.00
R010240804	24.00	38.00	8.00	R010250837	25.00	36.00	7.00
R010240832	24.00	38.00	10.00	R0102508A3	25.00	36.00	10.00
R020240882	24.00	40.00	4.00	R010250863	25.00	37.00	5.00
R010240840	24.00	40.00	7.00	R0102508C4	25.00	37.00	6.00
R020240824	24.00	40.00	7.00	R010250804	25.00	37.00	7.00
R020240820	24.00	40.00	8.00	R020250819	25.00	37.00	7.00
R010240842	24.00	40.00	10.00	R010250842	25.00	37.00	8.00
R010240853	24.00	42.00	7.00	R0102508C5	25.00	37.00	10.00
R010240838	24.00	42.00	8.00	R010250893	25.00	38.00	6.00
R020240801	24.00	42.00	8.00	R01025080B	25.00	38.00	7.00
R010240854	24.00	42.00	10.00	R020250820	25.00	38.00	7.00
R010240855	24.00	45.00	7.00	R010250835	25.00	38.00	8.00



**R01**

The **R01** type rotary shaft seal has a metal inserts (Bonded) encased in rubber.

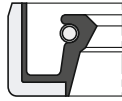

**R15**

The **R15** type rotary shaft seal has a metal encased on the outer diameter.



**R02**

The **R02** type rotary shaft seal is similar to R01 type but with an additional dust lip.

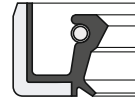

**R17**

The **R17** type rotary shaft seal is similar to R15 type but with an additional dust lip.

Max Spare Part No.	Shaft Dia.	Hsg. Dia.	Seal Ht.	Max Spare Part No.	Shaft Dia.	Hsg. Dia.	Seal Ht.
R010250876	25.00	38.00	10.00	R020250808	25.00	47.00	7.00
R0102508C6	25.00	40.00	5.00	R170250806	25.00	47.00	7.00
R010250809	25.00	40.00	6.00	R010250860	25.00	47.00	8.00
R0102508F2	25.00	40.00	6.80	R010250807	25.00	47.00	10.00
R010250812	25.00	40.00	7.00	R020250801	25.00	47.00	10.00
R020250818	25.00	40.00	7.00	R010250895	25.00	48.00	8.00
R150250836	25.00	40.00	7.00	R010250874	25.00	48.00	10.00
R170250802	25.00	40.00	7.00	R01025080T	25.00	50.00	7.00
R010250888	25.00	40.00	8.00	R01025081C	25.00	50.00	8.00
R020250817	25.00	40.00	8.00	R010250865	25.00	50.00	10.00
R010250843	25.00	40.00	9.00	R0102508A9	25.00	52.00	6.00
R0202508A9	25.00	40.00	9.00	R010250801	25.00	52.00	7.00
R010250811	25.00	40.00	10.00	R020250812	25.00	52.00	7.00
R020250802	25.00	40.00	10.00	R170250816	25.00	52.00	7.00
R0102508C7	25.00	41.00	7.00	R010250855	25.00	52.00	8.00
R0102508F3	25.00	41.00	9.50	R010250808	25.00	52.00	10.00
R0102508M5	25.00	42.00	5.00	R020250811	25.00	52.00	10.00
R010250806	25.00	42.00	6.00	R01025081R	25.00	54.00	10.00
R020250839	25.00	42.00	6.00	R01025081U	25.00	55.00	10.00
R010250852	25.00	42.00	7.00	R01025081X	25.00	56.00	10.00
R020250807	25.00	42.00	7.00	R010250845	25.00	57.00	10.00
R01025080F	25.00	42.00	8.00	R01025081Z	25.00	60.00	10.00
R010250813	25.00	42.00	10.00	R010250858	25.00	62.00	7.00
R0202508F4	25.00	42.00	10.00	R0102508J7	25.00	62.00	7.50
R010250810	25.00	43.00	8.00	R010250859	25.00	62.00	8.00
R010250816	25.00	44.00	7.00	R01025082A	25.00	62.00	10.00
R010250800	25.00	44.00	8.00	R170250807	25.40	38.10	6.35
R010250889	25.00	44.00	10.00	R01025082E	25.40	38.10	9.52
R010250894	25.00	45.00	5.00	R0102508C8	25.40	41.27	8.00
R010250898	25.00	45.00	7.00	R0102508C9	25.40	41.27	9.52
R010250880	25.00	45.00	8.00	R010250821	25.40	44.45	6.35
R010250841	25.00	45.00	10.00	R0102508A5	25.40	44.45	9.52
R020250829	25.00	45.00	10.00	R0102508D1	25.40	50.80	9.52
R01025082T	25.00	46.00	7.00	R0102508D2	25.40	50.80	12.70
R0102508F4	25.00	46.00	10.00	R010260838	26.00	34.00	4.00
R0102508L4	25.00	47.00	6.35	R010260811	26.00	35.00	6.00
R010250815	25.00	47.00	7.00	R170260801	26.00	35.00	6.00



**R01**

The **R01** type rotary shaft seal has a metal inserts (Bonded) encased in rubber.



**R15**

The **R15** type rotary shaft seal has a metal encased on the outer diameter.



**R02**

The **R02** type rotary shaft seal is similar to R01 type but with an additional dust lip.



**R17**

The **R17** type rotary shaft seal is similar to R15 type but with an additional dust lip.

Max Spare Part No.	Shaft Dia.	Hsg. Dia.	Seal Ht.	Max Spare Part No.	Shaft Dia.	Hsg. Dia.	Seal Ht.
R010260839	26.00	35.00	7.60	R0102808C7	28.00	38.00	9.00
R010260805	26.00	37.00	7.00	R01028080F	28.00	38.00	10.00
R010260834	26.00	38.00	5.00	R0102808H5	28.00	40.00	5.00
R010260840	26.00	38.00	7.00	R01028082E	28.00	40.00	6.00
R010260841	26.00	38.00	8.00	R010280802	28.00	40.00	7.00
R010260824	26.00	40.00	7.00	R020280831	28.00	40.00	7.00
R010260842	26.00	42.00	6.00	R010280851	28.00	40.00	8.00
R010260809	26.00	42.00	7.00	R010280871	28.00	40.00	10.00
R010260801	26.00	42.00	8.00	R010280821	28.00	41.00	7.00
R010260835	26.00	42.00	10.00	R01028080G	28.00	42.00	7.00
R010260825	26.00	47.00	7.00	R010280845	28.00	42.00	8.00
R010260806	26.00	47.00	10.00	R010280842	28.00	42.00	10.00
R010260826	26.00	48.00	10.00	R010280801	28.00	43.00	7.00
R010260808	26.00	50.00	10.00	R010280805	28.00	43.00	8.00
R010260836	26.00	52.00	7.00	R0102808C8	28.00	43.00	9.53
R010270850	27.00	35.00	7.00	R010280838	28.00	43.00	10.00
R010270819	27.00	37.00	7.00	R010280822	28.00	44.00	7.00
R010270847	27.00	37.00	10.00	R01028080H	28.00	44.00	8.00
R010270842	27.00	40.00	6.00	R0102808C9	28.00	44.00	10.00
R010270804	27.00	40.00	7.00	R010280819	28.00	45.00	7.00
R010270859	27.00	40.00	8.00	R010280873	28.00	45.00	8.00
R010270874	27.00	40.00	10.00	R020280803	28.00	45.00	8.00
R010270851	27.00	41.00	10.00	R01028081Q	28.00	45.00	10.00
R010270831	27.00	42.00	7.00	R010280837	28.00	46.00	10.00
R010270822	27.00	42.00	10.00	R0102808D1	28.00	47.00	5.00
R010270860	27.00	43.00	9.00	R010280818	28.00	47.00	7.00
R010270803	27.00	45.00	10.00	R020280802	28.00	47.00	7.00
R010270849	27.00	47.00	6.00	R0102808B6	28.00	47.00	8.00
R010270824	27.00	47.00	10.00	R010280875	28.00	47.00	10.00
R010270852	27.00	47.00	11.00	R020280834	28.00	47.00	10.00
R010270853	27.00	50.00	10.00	R010280858	28.00	48.00	8.00
R010280815	28.00	35.00	7.00	R010280854	28.00	48.00	10.00
R0102808C6	28.00	35.00	10.00	R01028080J	28.00	50.00	7.00
R010280849	28.00	38.00	6.00	R010280835	28.00	50.00	8.00
R010280804	28.00	38.00	7.00	R010280843	28.00	50.00	10.00
R020280830	28.00	38.00	7.00	R0202808B10	28.00	50.00	10.00
R01028080E	28.00	38.00	8.00	R010280827	28.00	52.00	7.00



**R01**

The **R01** type rotary shaft seal has a metal inserts (Bonded) encased in rubber.

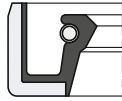

**R15**

The **R15** type rotary shaft seal has a metal encased on the outer diameter.



**R02**

The **R02** type rotary shaft seal is similar to R01 type but with an additional dust lip.

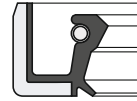

**R17**

The **R17** type rotary shaft seal is similar to R15 type but with an additional dust lip.

Max Spare Part No.	Shaft Dia.	Hsg. Dia.	Seal Ht.	Max Spare Part No.	Shaft Dia.	Hsg. Dia.	Seal Ht.
R01028080L	28.00	52.00	8.00	R010300895	30.00	40.00	10.00
R010280831	28.00	52.00	10.00	R01030080D	30.00	42.00	6.00
R01028080O	28.00	54.00	8.00	R010300803	30.00	42.00	7.00
R01028080S	28.00	55.00	8.00	R020300802	30.00	42.00	7.00
R01028080U	28.00	56.00	8.00	R170300802	30.00	42.00	7.00
R01028080V	28.00	56.00	10.00	R150300853	30.00	42.00	7.00
R0102808D2	28.00	57.00	10.00	R010300855	30.00	42.00	8.00
R01028080Z	28.57	38.10	6.35	R020300826	30.00	42.00	8.00
R0202808A5	28.57	38.10	6.35	R010300872	30.00	42.00	10.00
R01028081P	28.57	38.10	9.52	R020300871	30.00	42.00	10.00
R0102808B7	28.57	47.62	8.00	R0103008BN	30.00	42.00	11.00
R01028081C	28.57	47.62	9.52	R010300825	30.00	43.00	8.00
R0102808A2	28.57	50.80	12.70	R01030080J	30.00	44.00	7.00
R0102808B8	28.57	57.15	9.52	R01030080N	30.00	44.00	8.00
R010290834	29.00	40.00	10.00	R0103008BO	30.00	44.00	9.00
R010290835	29.00	41.00	5.00	R01030080M	30.00	45.00	6.00
R010290836	29.00	42.00	7.00	R010300874	30.00	45.00	7.00
R010290837	29.00	42.00	10.00	R020300872	30.00	45.00	7.00
R010290838	29.00	43.00	7.00	R010300844	30.00	45.00	8.00
R010290839	29.00	43.00	10.00	R020300834	30.00	45.00	8.00
R010290840	29.00	44.00	10.00	R010300886	30.00	45.00	10.00
R010290830	29.00	45.00	9.50	R020300869	30.00	45.00	10.00
R010290841	29.00	46.00	10.00	R0103008BP	30.00	46.00	7.00
R010290806	29.00	47.00	10.00	R010300890	30.00	46.00	10.00
R010290820	29.00	48.00	10.00	R0103008D1	30.00	47.00	5.00
R010290821	29.00	50.00	10.00	R010300882	30.00	47.00	6.00
R010290842	29.00	56.00	16.00	R010300804	30.00	47.00	7.00
R010290843	29.00	57.00	10.00	R020300820	30.00	47.00	7.00
R0103008C5	30.00	38.00	7.00	R170300809	30.00	47.00	7.00
R010300834	30.00	40.00	4.00	R150300801	30.00	47.00	7.00
R010300896	30.00	40.00	5.00	R01030080O	30.00	47.00	8.00
R01030080G	30.00	40.00	6.00	R010300810	30.00	47.00	10.00
R010300801	30.00	40.00	7.00	R020300806	30.00	47.00	10.00
R020300801	30.00	40.00	7.00	R01030080F	30.00	48.00	7.00
R150300818	30.00	40.00	7.00	R010300865	30.00	48.00	8.00
R01030080C	30.00	40.00	8.00	R010300883	30.00	48.00	10.00
R020300867	30.00	40.00	8.00	R0103008G6	30.00	50.00	5.00



**R01**

The **R01** type rotary shaft seal has a metal inserts (Bonded) encased in rubber.



**R15**

The **R15** type rotary shaft seal has a metal encased on the outer diameter.



**R02**

The **R02** type rotary shaft seal is similar to R01 type but with an additional dust lip.



**R17**

The **R17** type rotary shaft seal is similar to R15 type but with an additional dust lip.

Max Spare Part No.	Shaft Dia.	Hsg. Dia.	Seal Ht.	Max Spare Part No.	Shaft Dia.	Hsg. Dia.	Seal Ht.
R010300894	30.00	50.00	7.00	R010300840	30.00	60.00	12.00
R020300832	30.00	50.00	7.00	R010300807	30.00	62.00	7.00
R010300877	30.00	50.00	8.00	R020300836	30.00	62.00	7.00
R020300814	30.00	50.00	8.00	R010300857	30.00	62.00	8.00
R010300846	30.00	50.00	10.00	R020300868	30.00	62.00	8.00
R020300819	30.00	50.00	10.00	R010300808	30.00	62.00	10.00
R010300848	30.00	50.00	11.00	R020300830	30.00	62.00	10.00
R010300835	30.00	50.00	12.00	R010300826	30.00	62.00	12.00
R0103008BQ	30.00	51.00	7.00	R0103008BR	30.00	65.00	10.00
R010300809	30.00	51.00	10.00	R0103008BS	30.00	70.00	10.00
R010300822	30.00	52.00	5.00	R0103008BT	30.00	72.00	7.00
R0103008G8	30.00	52.00	6.00	R010300814	30.00	72.00	8.00
R010300805	30.00	52.00	7.00	R020300860	30.00	72.00	8.00
R020300807	30.00	52.00	7.00	R010300813	30.00	72.00	10.00
R170300807	30.00	52.00	7.00	R010310877	31.00	47.00	7.00
R010300824	30.00	52.00	8.00	R010310818	31.00	52.00	7.00
R020300809	30.00	52.00	8.00	R010310881	31.75	44.45	6.35
R01030081L	30.00	52.00	9.00	R010310887	31.75	47.62	8.00
R010300806	30.00	52.00	10.00	R010310827	31.75	50.80	9.52
R020300810	30.00	52.00	10.00	R150310809	31.75	50.80	6.35
R150300863	30.00	52.00	10.00	R010310831	31.75	57.15	9.52
R01030080Y	30.00	52.00	12.00	R010320885	32.00	40.00	7.00
R01030080Z	30.00	54.00	8.00	R0103208A3	32.00	42.00	4.00
R010300864	30.00	54.00	10.00	R010320881	32.00	42.00	5.00
R010300898	30.00	55.00	7.00	R010320847	32.00	42.00	7.00
R020300804	30.00	55.00	7.00	R010320872	32.00	42.00	8.00
R010300811	30.00	55.00	8.00	R010320841	32.00	44.00	7.00
R010300817	30.00	55.00	10.00	R010320871	32.00	44.00	10.00
R020300838	30.00	55.00	10.00	R010320862	32.00	45.00	6.00
R020300901	30.00	55.00	10.00	R010320802	32.00	45.00	7.00
R01030081C	30.00	56.00	8.00	R020320808	32.00	45.00	7.00
R010300863	30.00	56.00	10.00	R010320803	32.00	45.00	8.00
R0103008BL	30.00	56.00	12.00	R020320887	32.00	45.00	8.00
R010300837	30.00	57.00	10.00	R010320868	32.00	45.00	10.00
R01030081E	30.00	58.00	8.00	R010320863	32.00	46.00	10.00
R01030081I	30.00	60.00	8.00	R010320887	32.00	47.00	7.00
R010300815	30.00	60.00	10.00	R020320820	32.00	47.00	7.00

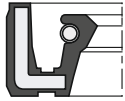

**R01**

The **R01** type rotary shaft seal has a metal inserts (Bonded) encased in rubber.



**R15**

The **R15** type rotary shaft seal has a metal encased on the outer diameter.



**R02**

The **R02** type rotary shaft seal is similar to R01 type but with an additional dust lip.

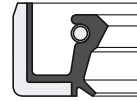

**R17**

The **R17** type rotary shaft seal is similar to R15 type but with an additional dust lip.

Max Spare Part No.	Shaft Dia.	Hsg. Dia.	Seal Ht.	Max Spare Part No.	Shaft Dia.	Hsg. Dia.	Seal Ht.
R010320870	32.00	47.00	8.00	R010330848	33.00	54.00	10.00
R010320835	32.00	47.00	10.00	R010330859	33.00	68.00	10.00
R010320849	32.00	48.00	7.00	R0103408D3	34.00	41.00	4.00
R010320880	32.00	48.00	8.00	R0103408D4	34.00	46.00	11.00
R020320896	32.00	48.00	8.00	R0103408D5	34.00	46.20	8.00
R010320853	32.00	48.00	10.00	R0103408B8	34.00	47.00	7.00
R010320874	32.00	50.00	7.00	R010340811	34.00	48.00	8.00
R010320859	32.00	50.00	8.00	R0103408B9	34.00	50.00	7.00
R010320869	32.00	50.00	10.00	R0103408D8	34.00	50.00	9.00
R01032080F	32.00	52.00	5.00	R010340816	34.00	50.00	10.00
R010320801	32.00	52.00	7.00	R0103408D6	34.00	51.00	10.00
R010320807	32.00	52.00	8.00	R010340810	34.00	52.00	10.00
R010320844	32.00	52.00	10.00	R0103408D7	34.00	54.00	7.00
R010320855	32.00	52.00	12.00	R010340803	34.00	54.00	10.00
R010320811	32.00	54.00	10.00	R010340834	34.92	47.62	7.93
R010320813	32.00	55.00	10.00	R010340839	34.92	47.62	9.52
R010320842	32.00	56.00	10.00	R010340842	34.92	50.80	9.52
R010320812	32.00	57.00	10.00	R010340857	34.92	52.38	6.35
R010320810	32.00	58.00	10.00	R010340843	34.92	53.97	9.52
R010320809	32.00	60.00	10.00	R010340845	34.92	57.15	9.52
R01032080D	32.00	62.00	7.00	R010340846	34.92	57.15	12.70
R010320805	32.00	62.00	10.00	R010340867	34.92	60.32	12.70
R0103208A8	32.00	65.00	10.00	R0103508C1	35.00	42.00	7.00
R0103208A9	32.00	70.00	8.00	R0103508D4	35.00	42.00	10.00
R0103208B1	32.00	70.00	10.00	R0103508D5	35.00	43.00	4.00
R010330851	33.00	40.00	7.00	R0103508K7	35.00	45.00	4.00
R010330854	33.00	43.00	7.00	R0103508F5	35.00	45.00	5.00
R010330855	33.00	45.00	8.00	R01035081V	35.00	45.00	6.00
R010330856	33.00	46.00	7.00	R010350890	35.00	45.00	7.00
R010330824	33.00	47.00	7.00	R020350866	35.00	45.00	7.00
R010330826	33.00	47.00	10.00	R010350893	35.00	45.00	8.00
R010330849	33.00	48.00	7.00	R010350891	35.00	45.00	10.00
R010330802	33.00	48.00	8.00	R010350853	35.00	46.00	7.00
R010330857	33.00	48.00	10.00	R0103508D6	35.00	46.00	10.00
R010330850	33.00	50.00	6.00	R020350871	35.00	47.00	6.00
R010330814	33.00	52.00	6.00	R010350806	35.00	47.00	7.00
R010330808	33.00	52.00	10.00	R020350802	35.00	47.00	7.00

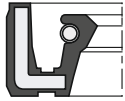

**R01**

The **R01** type rotary shaft seal has a metal inserts (Bonded) encased in rubber.



**R15**

The **R15** type rotary shaft seal has a metal encased on the outer diameter.



**R02**

The **R02** type rotary shaft seal is similar to R01 type but with an additional dust lip.

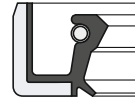

**R17**

The **R17** type rotary shaft seal is similar to R15 type but with an additional dust lip.

Max Spare Part No.	Shaft Dia.	Hsg. Dia.	Seal Ht.	Max Spare Part No.	Shaft Dia.	Hsg. Dia.	Seal Ht.
R150350813	35.00	47.00	7.00	R01035080M	35.00	55.00	13.00
R170350802	35.00	47.00	7.00	R010350871	35.00	56.00	7.00
R0103508B1	35.00	47.00	8.00	R010350838	35.00	56.00	10.00
R010350878	35.00	47.00	10.00	R020350803	35.00	56.00	10.00
R010350889	35.00	48.00	6.00	R010350821	35.00	56.00	12.00
R0103508A6	35.00	48.00	7.00	R010350867	35.00	57.00	7.00
R010350894	35.00	48.00	8.00	R010350883	35.00	57.00	8.00
R020350814	35.00	48.00	8.00	R010350807	35.00	57.00	10.00
R010350801	35.00	48.00	10.00	R010350851	35.00	57.00	12.00
R010350864	35.00	50.00	7.00	R010350895	35.00	58.00	8.00
R020350832	35.00	50.00	7.00	R010350835	35.00	58.00	10.00
R150350871	35.00	50.00	7.00	R010350898	35.00	58.00	12.00
R010350879	35.00	50.00	8.00	R01035080B	35.00	60.00	7.00
R020350885	35.00	50.00	8.00	R01035080K	35.00	60.00	8.00
R010350804	35.00	50.00	10.00	R01035081P	35.00	60.00	10.00
R020350807	35.00	50.00	10.00	R020350889	35.00	60.00	10.00
R010350801	35.00	51.00	10.00	R01035080Z	35.00	60.00	12.00
R0103508E5	35.00	52.00	5.00	R020350845	35.00	60.00	12.00
R0103508D7	35.00	52.00	5.80	R0103508D8	35.00	60.00	13.00
R0103508A3	35.00	52.00	6.00	R0103508D9	35.00	60.00	14.00
R010350813	35.00	52.00	7.00	R0103508E1	35.00	61.00	6.00
R020350801	35.00	52.00	7.00	R0103508E2	35.00	62.00	6.00
R01035081B	35.00	52.00	8.00	R010350803	35.00	62.00	7.00
R020350847	35.00	52.00	8.00	R010350901	35.00	62.00	7.00
R010350800	35.00	52.00	9.00	R020350826	35.00	62.00	7.00
R010350814	35.00	52.00	10.00	R170350805	35.00	62.00	7.00
R020350853	35.00	52.00	10.00	R010350848	35.00	62.00	8.00
R010350844	35.00	54.00	10.00	R010350843	35.00	62.00	10.00
R020350850	35.00	54.00	10.00	R020350857	35.00	62.00	10.00
R0103508B9	35.00	55.00	5.00	R010350829	35.00	62.00	12.00
R010350811	35.00	55.00	7.00	R01035080G	35.00	63.00	10.00
R010350808	35.00	55.00	8.00	R010350837	35.00	65.00	10.00
R020350877	35.00	55.00	8.00	R020350898	35.00	65.00	10.00
R010350805	35.00	55.00	10.00	R0103508C5	35.00	65.00	12.00
R020350804	35.00	55.00	10.00	R010350836	35.00	68.00	10.00
R010350884	35.00	55.00	11.00	R010350802	35.00	70.00	7.00
R020350831	35.00	55.00	11.00	R010350858	35.00	70.00	10.00



**R01**

The **R01** type rotary shaft seal has a metal inserts (Bonded) encased in rubber.



**R15**

The **R15** type rotary shaft seal has a metal encased on the outer diameter.



**R02**

The **R02** type rotary shaft seal is similar to R01 type but with an additional dust lip.

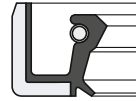

**R17**

The **R17** type rotary shaft seal is similar to R15 type but with an additional dust lip.

Max Spare Part No.	Shaft Dia.	Hsg. Dia.	Seal Ht.	Max Spare Part No.	Shaft Dia.	Hsg. Dia.	Seal Ht.
R010350823	35.00	72.00	7.00	R010380856	38.00	50.00	10.00
R020350873	35.00	72.00	7.00	R0103808D3	38.00	51.00	10.00
R01035081F	35.00	72.00	8.00	R010380804	38.00	52.00	7.00
R01035080L	35.00	72.00	10.00	R020380838	38.00	52.00	7.00
R020350856	35.00	72.00	10.00	R010380801	38.00	52.00	8.00
R01035080R	35.00	72.00	12.00	R010380842	38.00	52.00	10.00
R010350816	35.00	75.00	10.00	R020380851	38.00	52.00	10.00
R010350812	35.00	80.00	10.00	R010380893	38.00	54.00	8.00
R010360810	36.00	47.00	7.00	R010380826	38.00	54.00	10.00
R010360832	36.00	48.00	10.00	R010380895	38.00	54.00	12.00
R010360818	36.00	50.00	7.00	R010380805	38.00	55.00	7.00
R010360850	36.00	50.00	10.00	R020380806	38.00	55.00	7.00
R010360807	36.00	52.00	7.00	R170380804	38.00	55.00	7.00
R170360805	36.00	52.00	7.00	R010380802	38.00	55.00	8.00
R010360843	36.00	52.00	10.00	R010380815	38.00	55.00	10.00
R010360853	36.00	54.00	7.50	R010380843	38.00	56.00	8.00
R010360835	36.00	55.00	7.00	R010380810	38.00	56.00	10.00
R010360858	36.00	55.00	10.00	R010380800	38.00	57.00	8.00
R010360837	36.00	60.00	10.00	R01038080N	38.00	57.00	10.00
R010360838	36.00	62.00	7.00	R01038080U	38.00	57.00	12.00
R010360839	36.00	62.00	10.00	R0103808D4	38.00	58.00	9.00
R010360840	36.00	65.00	10.00	R010380849	38.00	58.00	10.00
R010360841	36.00	68.00	10.00	R010380808	38.00	58.00	11.00
R010370830	37.00	47.00	7.00	R010380881	38.00	58.00	12.00
R010370835	37.00	47.00	10.00	R010380885	38.00	60.00	10.00
R010370805	37.00	52.00	8.00	R0103808D6	38.00	61.00	6.00
R010370836	37.00	55.00	7.00	R010380807	38.00	62.00	7.00
R010370831	37.00	55.00	10.00	R0103808E5	38.00	62.00	8.00
R010370837	37.00	58.00	10.00	R010380806	38.00	62.00	10.00
R010370838	37.00	60.00	10.00	R01038080Z	38.00	64.00	10.00
R010370808	37.00	62.00	8.00	R0103808D7	38.00	65.00	8.00
R010370819	37.00	62.00	10.00	R010380878	38.00	65.00	10.00
R010380868	38.00	47.00	10.00	R010380820	38.00	68.00	10.00
R010380852	38.00	48.00	8.00	R010380877	38.00	70.00	10.00
R010380831	38.00	50.00	7.00	R01038081G	38.00	70.00	12.00
R020380835	38.00	50.00	7.00	R0103808d8	38.00	72.00	5.00
R010380863	38.00	50.00	8.00	R010380813	38.00	72.00	10.00



**R01**

The **R01** type rotary shaft seal has a metal inserts (Bonded) encased in rubber.



**R15**

The **R15** type rotary shaft seal has a metal encased on the outer diameter.



**R02**

The **R02** type rotary shaft seal is similar to R01 type but with an additional dust lip.

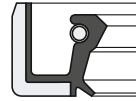

**R17**

The **R17** type rotary shaft seal is similar to R15 type but with an additional dust lip.

Max Spare Part No.	Shaft Dia.	Hsg. Dia.	Seal Ht.	Max Spare Part No.	Shaft Dia.	Hsg. Dia.	Seal Ht.
R010380850	38.00	73.00	10.00	R010400834	40.00	54.00	10.00
R010380811	38.00	75.00	10.00	R010400801	40.00	55.00	5.00
R01038081J	38.00	80.00	10.00	R0104008C3	40.00	55.00	6.00
R01038081M	38.10	50.80	7.93	R020400833	40.00	55.00	6.00
R170380829	38.10	50.80	8.00	R010400803	40.00	55.00	7.00
R01038082E	38.10	52.38	12.70	R020400803	40.00	55.00	7.00
R01038081Q	38.10	57.15	9.52	R150400801	40.00	55.00	7.00
R01038081R	38.10	57.15	12.70	R010400880	40.00	55.00	8.00
R0103808A2	38.10	60.32	9.52	R020400814	40.00	55.00	8.00
R0103808B6	38.10	63.50	9.52	R150400842	40.00	55.00	8.00
R01038081L	38.10	63.50	12.70	R010400836	40.00	55.00	10.00
R01038082H	38.10	68.26	12.70	R020400825	40.00	55.00	10.00
R0103808D9	38.10	69.85	9.52	R010400857	40.00	56.00	8.00
R0103808J4	38.10	69.95	7.95	R010400801	40.00	56.00	10.00
R010390816	39.00	57.00	9.00	R010400892	40.00	57.00	10.00
R010390827	39.00	60.00	10.00	R010400818	40.00	58.00	8.00
R010390820	39.75	68.20	9.52	R020400849	40.00	58.00	8.00
R010390821	39.75	73.02	12.70	R0104008H5	40.00	58.00	9.00
R0104008B5	40.00	48.00	7.00	R010400833	40.00	58.00	10.00
R010400874	40.00	50.00	5.00	R020400878	40.00	58.00	10.00
R01040080Y	40.00	50.00	6.00	R010400871	40.00	58.00	12.00
R020400855	40.00	50.00	6.00	R0104008D2	40.00	59.00	10.00
R01040080N	40.00	50.00	7.00	R010400827	40.00	60.00	7.00
R010400875	40.00	50.00	8.00	R01040080C	40.00	60.00	8.00
R010400838	40.00	50.00	10.00	R020400811	40.00	60.00	8.00
R020400827	40.00	50.00	10.00	R010400808	40.00	60.00	10.00
R010400832	40.00	52.00	5.00	R020400802	40.00	60.00	10.00
R010400895	40.00	52.00	6.00	R150400804	40.00	60.00	10.00
R010400804	40.00	52.00	7.00	R010400813	40.00	60.00	12.00
R020400813	40.00	52.00	7.00	R010400867	40.00	60.00	13.00
R150400805	40.00	52.00	7.00	R010400830	40.00	62.00	5.00
R170400801	40.00	52.00	7.00	R010400897	40.00	62.00	7.00
R010400822	40.00	52.00	8.00	R020400829	40.00	62.00	7.00
R020400862	40.00	52.00	8.00	R150400817	40.00	62.00	7.00
R150400840	40.00	52.00	8.00	R010400891	40.00	62.00	8.00
R010400821	40.00	52.00	10.00	R020400842	40.00	62.00	8.00
R0104008J8	40.00	53.00	7.00	R150400836	40.00	62.00	8.00



**R01**

The **R01** type rotary shaft seal has a metal inserts (Bonded) encased in rubber.



**R15**

The **R15** type rotary shaft seal has a metal encased on the outer diameter.



**R02**

The **R02** type rotary shaft seal is similar to R01 type but with an additional dust lip.

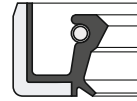

**R17**

The **R17** type rotary shaft seal is similar to R15 type but with an additional dust lip.

Max Spare Part No.	Shaft Dia.	Hsg. Dia.	Seal Ht.	Max Spare Part No.	Shaft Dia.	Hsg. Dia.	Seal Ht.
R010400840	40.00	62.00	9.00	R010400856	40.00	85.00	10.00
R010400809	40.00	62.00	10.00	R0104008K1	40.00	90.00	8.00
R020400808	40.00	62.00	10.00	R010400855	40.00	90.00	10.00
R150400828	40.00	62.00	10.00	R010410858	41.00	51.00	5.00
R010400898	40.00	62.00	11.50	R010410864	41.00	55.00	8.00
R010400865	40.00	62.00	12.00	R010410818	41.00	64.00	10.00
R020400805	40.00	62.00	12.00	R010410836	41.27	63.50	9.52
R160400805	40.00	62.00	12.00	R010410840	41.27	63.50	12.70
R0104008D3	40.00	63.00	5.00	R010410821	41.27	73.02	12.70
R010400896	40.00	63.00	10.00	R010420821	42.00	50.00	8.00
R010400876	40.00	64.00	10.00	R010420810	42.00	52.00	7.00
R010400807	40.00	65.00	7.00	R010420805	42.00	52.00	8.00
R010400847	40.00	65.00	8.00	R010420806	42.00	52.00	10.00
R010400810	40.00	65.00	10.00	R010420835	42.00	55.00	7.00
R020400822	40.00	65.00	10.00	R010420802	42.00	55.00	8.00
R170400806	40.00	65.00	10.00	R020420818	42.00	55.00	8.00
R010400882	40.00	65.00	12.00	R010420814	42.00	55.00	10.00
R010400884	40.00	66.00	10.00	R010420889	42.00	55.00	12.00
R0104008G7	40.00	68.00	7.00	R010420844	42.00	56.00	7.00
R010400890	40.00	68.00	8.00	R010420817	42.00	56.00	8.00
R020400840	40.00	68.00	8.00	R010420818	42.00	56.00	10.00
R01040080L	40.00	68.00	10.00	R010420879	42.00	58.00	7.00
R010400848	40.00	68.00	12.00	R010420871	42.00	58.00	10.00
R010400811	40.00	70.00	10.00	R010420812	42.00	60.00	7.00
R020400864	40.00	70.00	10.00	R010420838	42.00	60.00	8.00
R010400899	40.00	70.00	12.00	R010420846	42.00	60.00	10.00
R01040080R	40.00	72.00	7.00	R010420874	42.00	62.00	7.00
R010400819	40.00	72.00	8.00	R010420832	42.00	62.00	8.00
R010400883	40.00	72.00	10.00	R020420808	42.00	62.00	8.00
R020400823	40.00	72.00	10.00	R150420821	42.00	62.00	8.00
R010400829	40.00	72.00	12.00	R170420803	42.00	62.00	8.00
R01040080W	40.00	75.00	8.00	R010420803	42.00	62.00	10.00
R0104008C6	40.00	75.00	12.00	R020420828	42.00	62.00	10.00
R01040080U	40.00	78.00	10.00	R010420858	42.00	62.00	12.00
R0104008B2	40.00	80.00	7.00	R010420856	42.00	63.00	8.00
R010400805	40.00	80.00	10.00	R010420819	42.00	63.00	9.00
R020400826	40.00	80.00	10.00	R020420816	42.00	63.00	9.00



**R01**

The **R01** type rotary shaft seal has a metal inserts (Bonded) encased in rubber.

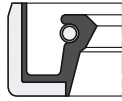

**R15**

The **R15** type rotary shaft seal has a metal encased on the outer diameter.



**R02**

The **R02** type rotary shaft seal is similar to R01 type but with an additional dust lip.

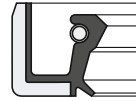

**R17**

The **R17** type rotary shaft seal is similar to R15 type but with an additional dust lip.

Max Spare Part No.	Shaft Dia.	Hsg. Dia.	Seal Ht.	Max Spare Part No.	Shaft Dia.	Hsg. Dia.	Seal Ht.
R010420815	42.00	63.00	10.00	R010440883	44.45	57.15	9.52
R020420821	42.00	63.00	10.00	R020440823	44.45	63.50	7.93
R010420822	42.00	64.00	10.00	R0104408B9	44.45	63.50	8.00
R010420857	42.00	65.00	7.00	R010440854	44.45	63.50	9.52
R010420887	42.00	65.00	8.00	R020440808	44.45	63.50	9.52
R010420837	42.00	65.00	10.00	R010440866	44.45	63.50	12.70
R020420825	42.00	65.00	10.00	R0104408B4	44.45	69.85	7.93
R010420813	42.00	65.00	12.00	R010440886	44.45	69.85	9.52
R010420848	42.00	68.00	10.00	R010440887	44.45	69.85	12.70
R010420840	42.00	70.00	10.00	R010440861	44.45	76.20	9.52
R020420851	42.00	72.00	6.00	R010450838	45.00	52.00	7.00
R010420839	42.00	72.00	7.00	R0104508C9	45.00	54.00	5.00
R010420824	42.00	72.00	8.00	R010450866	45.00	55.00	5.00
R010420801	42.00	72.00	10.00	R0104508A4	45.00	55.00	6.00
R020420804	42.00	72.00	10.00	R010450815	45.00	55.00	7.00
R010420829	42.00	72.00	12.00	R020450824	45.00	55.00	7.00
R010420842	42.00	75.00	10.00	R010450894	45.00	55.00	8.00
R010420827	42.00	80.00	10.00	R010450864	45.00	55.00	10.00
R010420870	42.00	85.00	10.00	R0104508D7	45.00	57.00	8.00
R010420890	42.67	63.50	9.52	R0104508A1	45.00	57.00	10.00
R010420875	42.67	63.50	12.70	R010450858	45.00	58.00	7.00
R010420880	42.80	63.50	9.52	R010450882	45.00	58.00	8.00
R010430823	43.00	58.00	7.00	R010450863	45.00	58.00	10.00
R010430807	43.00	64.00	10.00	R01045080G	45.00	60.00	6.00
R010430827	43.00	65.00	10.00	R170450804	45.00	60.00	6.00
R010430828	43.00	68.00	12.00	R010450803	45.00	60.00	7.00
R010440822	44.00	54.00	7.00	R020450805	45.00	60.00	7.00
R010440831	44.00	60.00	10.00	R010450805	45.00	60.00	8.00
R0104408B8	44.00	62.00	8.00	R020450838	45.00	60.00	8.00
R010440801	44.00	62.00	10.00	R150450808	45.00	60.00	8.00
R0104408D5	44.00	62.00	12.00	R01045080D	45.00	60.00	9.00
R010440845	44.00	63.00	10.00	R010450802	45.00	60.00	10.00
R010440807	44.00	64.00	8.00	R020450811	45.00	60.00	10.00
R010440826	44.00	64.00	10.00	R010450853	45.00	60.00	12.00
R010440895	44.00	65.00	10.00	R0104508B9	45.00	62.00	6.00
R0104408E7	44.00	70.00	10.00	R010450881	45.00	62.00	7.00
R0104408B7	44.45	57.15	6.35	R020450830	45.00	62.00	7.00



**R01**

The **R01** type rotary shaft seal has a metal inserts (Bonded) encased in rubber.



**R15**

The **R15** type rotary shaft seal has a metal encased on the outer diameter.



**R02**

The **R02** type rotary shaft seal is similar to R01 type but with an additional dust lip.

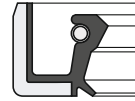

**R17**

The **R17** type rotary shaft seal is similar to R15 type but with an additional dust lip.

Max Spare Part No.	Shaft Dia.	Hsg. Dia.	Seal Ht.	Max Spare Part No.	Shaft Dia.	Hsg. Dia.	Seal Ht.
R010450850	45.00	62.00	8.00	R020450856	45.00	72.00	8.00
R020450801	45.00	62.00	8.00	R010450867	45.00	72.00	10.00
R0104508B6	45.00	62.00	9.00	R020450853	45.00	72.00	10.00
R020450818	45.00	62.00	9.00	R0104508A3	45.00	72.00	12.00
R010450879	45.00	62.00	10.00	R020450815	45.00	72.00	12.00
R020450820	45.00	62.00	10.00	R010450807	45.00	75.00	7.00
R150450842	45.00	62.00	10.00	R010450811	45.00	75.00	8.00
R010450843	45.00	62.00	12.00	R020450816	45.00	75.00	8.00
R020450835	45.00	62.00	12.00	R010450814	45.00	75.00	10.00
R0104508A7	45.00	63.00	10.00	R020450827	45.00	75.00	10.00
R150450851	45.00	63.00	10.00	R010450852	45.00	75.00	12.00
R010450887	45.00	64.00	8.00	R0104508A2	45.00	78.00	10.00
R010450851	45.00	64.00	10.00	R010450835	45.00	80.00	8.00
R010450801	45.00	65.00	7.00	R010450830	45.00	80.00	10.00
R020450849	45.00	65.00	7.00	R020450829	45.00	80.00	10.00
R010450861	45.00	65.00	8.00	R010450814	45.00	80.00	12.00
R020450807	45.00	65.00	8.00	R010450842	45.00	80.00	13.00
R010450804	45.00	65.00	10.00	R0104508D4	45.00	81.00	13.00
R020450825	45.00	65.00	10.00	R010450828	45.00	85.00	10.00
R150450804	45.00	65.00	10.00	R020450833	45.00	85.00	10.00
R010450831	45.00	65.00	12.00	R010450839	45.00	85.00	12.00
R020450836	45.00	65.00	12.00	R0104508A9	45.00	90.00	7.00
R0104508D1	45.00	66.00	7.00	R010450833	45.00	90.00	10.00
R010450816	45.00	67.00	10.00	R010450829	45.00	100.00	10.00
R010450808	45.00	68.00	8.00	R010460841	46.00	60.00	8.00
R020450876	45.00	68.00	8.00	R010460801	46.00	62.00	8.00
R0104508D2	45.00	68.00	9.00	R010460820	46.00	64.00	7.00
R010450880	45.00	68.00	10.00	R010460823	46.00	67.00	10.00
R010450889	45.00	68.00	12.00	R010460824	46.00	73.00	12.00
R0104508D3	45.00	70.00	5.00	R010470890	47.00	58.00	7.00
R0104508B4	45.00	70.00	7.00	R010470891	47.00	60.00	7.00
R01045080F	45.00	70.00	8.00	R010470892	47.00	60.00	10.00
R010450869	45.00	70.00	10.00	R0104708B1	47.00	62.00	6.00
R020450864	45.00	70.00	10.00	R010470823	47.00	62.00	8.00
R010450892	45.00	70.00	12.00	R010470870	47.00	65.00	10.00
R020450847	45.00	70.00	12.00	R010470830	47.00	67.00	10.00
R010450813	45.00	72.00	8.00	R010470893	47.00	70.00	7.00



**R01**

The **R01** type rotary shaft seal has a metal inserts (Bonded) encased in rubber.



**R15**

The **R15** type rotary shaft seal has a metal encased on the outer diameter.



**R02**

The **R02** type rotary shaft seal is similar to R01 type but with an additional dust lip.

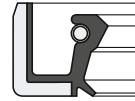

**R17**

The **R17** type rotary shaft seal is similar to R15 type but with an additional dust lip.

Max Spare Part No.	Shaft Dia.	Hsg. Dia.	Seal Ht.	Max Spare Part No.	Shaft Dia.	Hsg. Dia.	Seal Ht.
R010470877	47.00	70.00	10.00	R0104808A2	48.00	78.00	10.00
R010470894	47.00	70.00	12.00	R010480818	48.00	80.00	10.00
R0104708C3	47.00	72.00	8.00	R020480833	48.00	80.00	10.00
R0104708A9	47.00	90.00	10.00	R0104808B5	48.00	85.00	12.00
R010470895	47.50	76.20	4.06	R010490825	49.00	70.00	10.00
R010470885	47.62	63.50	9.52	R010490835	49.15	69.85	9.52
R010470859	47.62	66.67	9.52	R0105008A7	50.00	60.00	5.00
R010470850	47.62	69.85	12.70	R0105008G8	50.00	60.00	6.00
R010470886	47.62	73.02	12.70	R01050081S	50.00	60.00	7.00
R010470839	47.62	76.20	12.70	R010500838	50.00	60.00	8.00
R0104808B2	48.00	58.00	4.00	R01050D505	50.00	60.00	8.00
R010480899	48.00	60.00	8.00	R150500803	50.00	60.00	8.00
R010480847	48.00	60.00	10.00	R150500803	50.00	60.00	8.00
R010480801	48.00	62.00	7.00	R010500862	50.00	60.00	10.00
R010480802	48.00	62.00	8.00	R010500863	50.00	62.00	5.00
R020480806	48.00	62.00	8.00	R010500805	50.00	62.00	7.00
R010480828	48.00	62.00	10.00	R020500819	50.00	62.00	7.00
R010480836	48.00	65.00	8.00	R150500805	50.00	62.00	7.00
R0104808B3	48.00	65.00	9.00	R010500828	50.00	62.00	8.00
R010480831	48.00	65.00	10.00	R020500807	50.00	62.00	8.00
R020480811	48.00	65.00	10.00	R01050081N	50.00	62.00	10.00
R170480801	48.00	65.00	10.00	R0105008M3	50.00	62.00	12.00
R010480857	48.00	65.00	12.00	R010500832	50.00	64.00	10.00
R0104808D6	48.00	67.00	10.00	R010500873	50.00	65.00	6.00
R0104808C9	48.00	68.00	8.00	R0105008A1	50.00	65.00	7.00
R010480815	48.00	68.00	10.00	R010500801	50.00	65.00	8.00
R020480836	48.00	68.00	10.00	R020500829	50.00	65.00	8.00
R010480856	48.00	70.00	8.00	R150500802	50.00	65.00	8.00
R010480846	48.00	70.00	10.00	R010500829	50.00	65.00	9.00
R010480819	48.00	70.00	12.00	R010500809	50.00	65.00	10.00
R010480804	48.00	72.00	8.00	R020500864	50.00	65.00	10.00
R020480821	48.00	72.00	8.00	R150500837	50.00	65.00	10.00
R170480804	48.00	72.00	8.00	R0105008E7	50.00	66.00	6.00
R010480834	48.00	72.00	10.00	R010500810	50.00	67.00	10.00
R010480850	48.00	72.00	12.00	R010500888	50.00	68.00	7.00
R0104808A1	48.00	75.00	10.00	R010500802	50.00	68.00	8.00
R0104808B4	48.00	75.00	12.00	R020500828	50.00	68.00	8.00



**R01**

The **R01** type rotary shaft seal has a metal inserts (Bonded) encased in rubber.

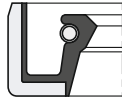

**R15**

The **R15** type rotary shaft seal has a metal encased on the outer diameter.



**R02**

The **R02** type rotary shaft seal is similar to R01 type but with an additional dust lip.

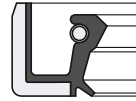

**R17**

The **R17** type rotary shaft seal is similar to R15 type but with an additional dust lip.

Max Spare Part No.	Shaft Dia.	Hsg. Dia.	Seal Ht.	Max Spare Part No.	Shaft Dia.	Hsg. Dia.	Seal Ht.
R170500805	50.00	68.00	8.00	R010500816	50.00	80.00	7.00
R010500846	50.00	68.00	9.00	R010500811	50.00	80.00	8.00
R010500813	50.00	68.00	10.00	R020500811	50.00	80.00	8.00
R020500824	50.00	68.00	10.00	R010500812	50.00	80.00	10.00
R010500880	50.00	68.00	12.00	R020500814	50.00	80.00	10.00
R010500848	50.00	70.00	8.00	R010500858	50.00	80.00	12.00
R020500868	50.00	70.00	8.00	R010500807	50.00	80.00	13.00
R010500804	50.00	70.00	10.00	R010500839	50.00	85.00	10.00
R020500803	50.00	70.00	10.00	R010500842	50.00	85.00	12.00
R150500824	50.00	70.00	10.00	R0105008M10	50.00	90.00	8.00
R010500884	50.00	70.00	12.00	R010500806	50.00	90.00	10.00
R020500871	50.00	70.00	12.00	R020500869	50.00	90.00	10.00
R150500809	50.00	70.00	12.00	R010500891	50.00	90.00	12.00
R01050080D	50.00	72.00	5.00	R01050080A	50.00	90.00	13.00
R010500841	50.00	72.00	7.00	R0105008A4	50.00	95.00	10.00
R0205008G2	50.00	72.00	7.00	R0105008H8	50.00	110.00	12.00
R010500803	50.00	72.00	8.00	R0105008C5	50.80	63.50	9.52
R020500862	50.00	72.00	8.00	R010500878	50.80	66.68	9.52
R150500801	50.00	72.00	8.00	R0105008A2	50.80	68.26	12.70
R010500830	50.00	72.00	10.00	R010500860	50.80	69.85	9.52
R020500804	50.00	72.00	10.00	R020500877	50.80	69.85	9.52
R150500804	50.00	72.00	10.00	R01050080U	50.80	69.85	12.70
R01050080E	50.00	72.00	12.00	R0105008E6	50.80	76.20	7.92
R020500805	50.00	72.00	12.00	R01050080X	50.80	76.20	9.52
R0105008E8	50.00	72.00	15.00	R010500826	50.80	76.20	12.70
R0105008E9	50.00	73.00	8.00	R010520854	52.00	63.00	10.00
R0105008F1	50.00	75.00	5.00	R010520828	52.00	65.00	10.00
R010500843	50.00	75.00	8.00	R010520844	52.00	68.00	7.00
R010500882	50.00	75.00	10.00	R010520802	52.00	68.00	8.00
R020500882	50.00	75.00	10.00	R010520818	52.00	68.00	10.00
R010500836	50.00	75.00	12.00	R010520830	52.00	70.00	8.00
R010500854	50.00	76.00	10.00	R010520850	52.00	70.00	9.00
R010500856	50.00	76.00	12.00	R010520822	52.00	70.00	10.00
R010500853	50.00	78.00	10.00	R010520832	52.00	70.00	12.00
R010500834	50.00	78.00	12.00	R010520811	52.00	72.00	8.00
R0105008A9	50.00	78.00	13.00	R020520814	52.00	72.00	8.00
R020500857	50.00	80.00	6.00	R010520813	52.00	72.00	10.00



**R01**

The **R01** type rotary shaft seal has a metal inserts (Bonded) encased in rubber.



**R15**

The **R15** type rotary shaft seal has a metal encased on the outer diameter.



**R02**

The **R02** type rotary shaft seal is similar to R01 type but with an additional dust lip.

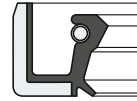

**R17**

The **R17** type rotary shaft seal is similar to R15 type but with an additional dust lip.

Max Spare Part No.	Shaft Dia.	Hsg. Dia.	Seal Ht.	Max Spare Part No.	Shaft Dia.	Hsg. Dia.	Seal Ht.
R020520828	52.00	72.00	10.00	R020550818	55.00	72.00	8.00
R010520821	52.00	72.00	12.00	R150550802	55.00	72.00	8.00
R020520821	52.00	72.00	12.00	R010550882	55.00	72.00	9.00
R010520833	52.00	75.00	10.00	R020550850	55.00	72.00	9.00
R010520801	52.00	75.00	12.00	R010550808	55.00	72.00	10.00
R020520815	52.00	75.00	12.00	R020550809	55.00	72.00	10.00
R010520810	52.00	78.00	10.00	R010550844	55.00	72.00	12.00
R010520835	52.00	80.00	10.00	R010550816	55.00	75.00	8.00
R010520809	52.00	85.00	10.00	R020550816	55.00	75.00	8.00
R010520840	52.00	90.00	10.00	R170550802	55.00	75.00	8.00
R010520855	52.00	92.00	10.00	R010550848	55.00	75.00	9.00
R010520863	52.00	100.00	10.00	R020550843	55.00	75.00	9.00
R010530838	53.00	83.00	10.00	R010550846	55.00	75.00	10.00
R010530843	53.00	92.00	11.50	R020550848	55.00	75.00	10.00
R010530833	53.97	76.20	9.52	R010550867	55.00	75.00	12.00
R010530820	53.97	76.20	12.70	R020550834	55.00	75.00	12.00
R010530834	53.97	79.37	12.70	R010550814	55.00	75.00	13.00
R010540825	54.00	70.00	8.00	R010550868	55.00	78.00	10.00
R010540848	54.00	72.00	8.00	R010550873	55.00	78.00	12.00
R010540838	54.00	72.00	10.00	R020550851	55.00	78.00	12.00
R010540812	54.00	76.00	8.00	R010550819	55.00	80.00	6.00
R010540805	54.00	80.00	13.00	R010550805	55.00	80.00	8.00
R010540849	54.00	81.00	10.00	R020550805	55.00	80.00	8.00
R010550857	55.00	65.00	6.00	R170550812	55.00	80.00	8.00
R010550827	55.00	65.00	8.00	R010550803	55.00	80.00	10.00
R010550875	55.00	65.00	10.00	R020550855	55.00	80.00	10.00
R010550856	55.00	68.00	8.00	R010550811	55.00	80.00	12.00
R010550829	55.00	68.00	10.00	R020550815	55.00	80.00	12.00
R010550802	55.00	70.00	8.00	R010550801	55.00	80.00	13.00
R020550819	55.00	70.00	8.00	R020550862	55.00	80.00	13.00
R170550819	55.00	70.00	8.00	R010550831	55.00	85.00	8.00
R150550803	55.00	70.00	8.00	R010550842	55.00	85.00	10.00
R010550845	55.00	70.00	10.00	R020550864	55.00	85.00	10.00
R020550810	55.00	70.00	10.00	R010550826	55.00	85.00	12.00
R010550864	55.00	70.00	12.00	R020550883	55.00	85.00	12.00
R010550891	55.00	72.00	7.00	R0105508A6	55.00	85.00	13.00
R010550806	55.00	72.00	8.00	R010550877	55.00	90.00	8.00

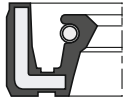

**R01**

The **R01** type rotary shaft seal has a metal inserts (Bonded) encased in rubber.



**R15**

The **R15** type rotary shaft seal has a metal encased on the outer diameter.



**R02**

The **R02** type rotary shaft seal is similar to R01 type but with an additional dust lip.

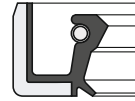

**R17**

The **R17** type rotary shaft seal is similar to R15 type but with an additional dust lip.

Max Spare Part No.	Shaft Dia.	Hsg. Dia.	Seal Ht.	Max Spare Part No.	Shaft Dia.	Hsg. Dia.	Seal Ht.
R020550868	55.00	90.00	8.00	R020580802	58.00	72.00	8.00
R010550810	55.00	90.00	10.00	R010580822	58.00	72.00	10.00
R020550813	55.00	90.00	10.00	R010580852	58.00	74.00	8.00
R010550815	55.00	90.00	12.00	R010580830	58.00	75.00	10.00
R010550878	55.00	90.00	13.00	R020580810	58.00	75.00	10.00
R010550879	55.00	95.00	10.00	R010580808	58.00	78.00	10.00
R0105508D5	55.00	100.00	8.00	R010580814	58.00	80.00	8.00
R010550809	55.00	100.00	10.00	R150580813	58.00	80.00	8.00
R020550812	55.00	100.00	10.00	R010580828	58.00	80.00	10.00
R010550869	55.00	100.00	13.00	R020580803	58.00	80.00	10.00
R010560819	56.00	70.00	8.00	R010580806	58.00	80.00	12.00
R010560811	56.00	70.00	12.00	R010580804	58.00	80.00	13.00
R010560806	56.00	72.00	8.00	R010580843	58.00	85.00	10.00
R010560822	56.00	75.00	10.00	R010580807	58.00	86.00	13.00
R010560807	56.00	76.00	10.00	R010580840	58.00	90.00	10.00
R010560824	56.00	78.00	10.00	R010600839	60.00	70.00	5.00
R010560826	56.00	80.00	8.00	R0106008C6	60.00	70.00	7.00
R010560827	56.00	85.00	8.00	R010600838	60.00	70.00	10.00
R010570879	57.00	72.00	10.00	R010600801	60.00	72.00	8.00
R010570873	57.00	76.00	9.00	R020600875	60.00	72.00	8.00
R010570806	57.00	76.00	10.00	R0106008G2	60.00	72.00	10.00
R010570868	57.00	80.00	10.00	R0106008C9	60.00	74.00	10.00
R010570805	57.00	85.00	12.00	R010600887	60.00	75.00	5.00
R010570842	57.15	69.85	9.52	R010600807	60.00	75.00	8.00
R010570877	57.15	73.02	12.70	R020600815	60.00	75.00	8.00
R010570801	57.15	76.20	9.52	R150600812	60.00	75.00	8.00
R010571901	57.15	76.20	9.52	R170600809	60.00	75.00	8.00
R020570803	57.15	76.20	9.52	R010600806	60.00	75.00	9.00
R150570818	57.15	76.20	9.52	R010600841	60.00	75.00	10.00
R010570850	57.15	76.20	12.70	R020600842	60.00	75.00	10.00
R010570878	57.15	82.55	9.52	R150600810	60.00	75.00	10.00
R010570854	57.15	82.55	12.70	R010600831	60.00	75.00	12.00
R010570851	57.15	85.72	9.52	R010600834	60.00	76.00	10.00
R010570831	57.15	85.72	12.70	R010600851	60.00	78.00	10.00
R010570852	57.15	88.90	12.70	R010600811	60.00	80.00	6.00
R010580819	58.00	70.00	10.00	R0106008B2	60.00	80.00	7.00
R010580823	58.00	72.00	8.00	R010600802	60.00	80.00	8.00



**R01**

The **R01** type rotary shaft seal has a metal inserts (Bonded) encased in rubber.



**R15**

The **R15** type rotary shaft seal has a metal encased on the outer diameter.



**R02**

The **R02** type rotary shaft seal is similar to R01 type but with an additional dust lip.

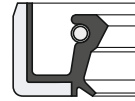

**R17**

The **R17** type rotary shaft seal is similar to R15 type but with an additional dust lip.

Max Spare Part No.	Shaft Dia.	Hsg. Dia.	Seal Ht.	Max Spare Part No.	Shaft Dia.	Hsg. Dia.	Seal Ht.
R020600801	60.00	80.00	8.00	R0106008A1	60.00	110.00	10.00
R150600836	60.00	80.00	8.00	R0106008E1	60.00	110.00	12.00
R170600803	60.00	80.00	8.00	R010600813	60.00	110.00	13.00
R010600816	60.00	80.00	9.00	R010600888	60.00	130.00	13.00
R010600804	60.00	80.00	10.00	R0106008B6	60.32	85.72	12.70
R020600819	60.00	80.00	10.00	R010620841	62.00	80.00	8.00
R150600832	60.00	80.00	10.00	R150620810	62.00	80.00	8.00
R170600819	60.00	80.00	10.00	R010620806	62.00	80.00	10.00
R010600855	60.00	80.00	12.00	R010620803	62.00	82.00	10.00
R020600873	60.00	80.00	12.00	R010620844	62.00	83.00	9.50
R010600857	60.00	80.00	13.00	R010620811	62.00	85.00	10.00
R010600819	60.00	82.00	7.00	R010620833	62.00	85.00	12.00
R010600845	60.00	82.00	10.00	R010620804	62.00	90.00	10.00
R010600822	60.00	82.00	12.00	R010620821	62.00	90.00	12.00
R020600804	60.00	82.00	12.00	R010620801	62.00	90.00	13.00
R010600823	60.00	85.00	8.00	R010620836	62.00	100.00	10.00
R020600833	60.00	85.00	8.00	R010620846	62.00	120.00	12.00
R010600803	60.00	85.00	10.00	R0106308G3	63.00	80.00	8.00
R020600822	60.00	85.00	10.00	R010630804	63.00	80.00	9.00
R150600820	60.00	85.00	10.00	R010630815	63.00	80.00	10.00
R010600808	60.00	85.00	12.00	R0106308F3	63.00	85.00	8.00
R020600803	60.00	85.00	12.00	R010630867	63.00	85.00	10.00
R010600809	60.00	85.00	13.00	R020630821	63.00	85.00	10.00
R020600851	60.00	85.00	13.00	R010630820	63.00	90.00	10.00
R010600810	60.00	90.00	8.00	R010630808	63.00	90.00	12.00
R020600835	60.00	90.00	8.00	R010630802	63.00	90.00	13.00
R010600826	60.00	90.00	10.00	R0106308A9	63.50	76.20	9.52
R020600810	60.00	90.00	10.00	R010630849	63.50	76.20	12.70
R150600831	60.00	90.00	10.00	R0106308C1	63.50	79.25	9.52
R010600889	60.00	90.00	11.00	R0106308C2	63.50	79.25	12.70
R010600833	60.00	90.00	12.00	R010630886	63.50	82.55	9.52
R010600890	60.00	90.00	13.00	R020630804	63.50	82.55	9.52
R010600805	60.00	95.00	10.00	R150630818	63.50	82.55	9.52
R020600858	60.00	95.00	10.00	R010630873	63.50	82.55	12.70
R010600821	60.00	95.00	13.00	R0106308B1	63.50	85.72	12.70
R010600817	60.00	100.00	10.00	R0106308B2	63.50	88.90	9.52
R010600898	60.00	100.00	13.00	R0106308C5	63.50	88.90	11.12



**R01**

The **R01** type rotary shaft seal has a metal inserts (Bonded) encased in rubber.

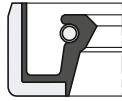

**R15**

The **R15** type rotary shaft seal has a metal encased on the outer diameter.



**R02**

The **R02** type rotary shaft seal is similar to R01 type but with an additional dust lip.



**R17**

The **R17** type rotary shaft seal is similar to R15 type but with an additional dust lip.

Max Spare Part No.	Shaft Dia.	Hsg. Dia.	Seal Ht.	Max Spare Part No.	Shaft Dia.	Hsg. Dia.	Seal Ht.
R010630895	63.50	88.90	12.70	R010650862	65.00	86.00	12.00
R020630842	63.50	89.91	11.93	R010650842	65.00	88.00	8.00
R010630851	63.50	89.91	12.70	R010650845	65.00	88.00	12.00
R020630827	63.50	89.91	12.70	R020650816	65.00	88.00	12.00
R0106308E5	63.50	89.92	9.52	R010650879	65.00	89.00	8.00
R0106308C3	63.50	89.92	10.92	R020650840	65.00	90.00	7.00
R010630801	63.50	89.92	11.94	R010650844	65.00	90.00	8.00
R0106308B3	63.50	90.04	12.06	R010650802	65.00	90.00	10.00
R0106308C4	63.50	91.95	14.22	R020650825	65.00	90.00	10.00
R0106308B4	63.50	95.25	9.52	R150650810	65.00	90.00	10.00
R0106308B5	63.50	95.25	12.70	R170650805	65.00	90.00	10.00
R010640807	64.00	80.00	8.00	R010650827	65.00	90.00	12.00
R010640829	64.00	80.00	10.00	R020650803	65.00	90.00	12.00
R010640802	64.00	88.00	12.00	R010650801	65.00	90.00	13.00
R010640843	64.00	90.00	10.00	R020650801	65.00	90.00	13.00
R010640803	64.00	90.00	13.00	R0106508D6	65.00	92.00	10.00
R010650840	65.00	75.00	5.00	R010650830	65.00	95.00	10.00
R010650838	65.00	75.00	8.00	R020650847	65.00	95.00	10.00
R010650857	65.00	75.00	10.00	R0106508A2	65.00	95.00	12.00
R010650899	65.00	80.00	6.00	R010650828	65.00	95.00	13.00
R170650804	65.00	80.00	7.00	R010650807	65.00	100.00	10.00
R010650855	65.00	80.00	8.00	R020650807	65.00	100.00	10.00
R020650812	65.00	80.00	8.00	R010650812	65.00	100.00	12.00
R150650816	65.00	80.00	8.00	R010650811	65.00	100.00	13.00
R010650803	65.00	80.00	10.00	R010650826	65.00	110.00	10.00
R020650813	65.00	80.00	10.00	R010650865	65.00	110.00	13.00
R010650836	65.00	80.00	12.00	R150650823	65.00	120.00	8.00
R010650825	65.00	82.00	10.00	R010650892	65.00	120.00	10.00
R010650816	65.00	85.00	8.00	R010650885	65.00	120.00	12.00
R020650836	65.00	85.00	8.00	R020650821	65.00	120.00	12.00
R010650804	65.00	85.00	10.00	R010650880	65.00	120.00	13.00
R020650805	65.00	85.00	10.00	R170650824	65.10	92.02	11.91
R150650818	65.00	85.00	10.00	R010660802	66.00	92.00	12.00
R170650807	65.00	85.00	10.00	R010660837	66.67	85.72	9.52
R010650805	65.00	85.00	12.00	R010680821	68.00	80.00	10.00
R020650833	65.00	85.00	12.00	R010680803	68.00	85.00	10.00
R010650843	65.00	85.00	13.00	R010680801	68.00	90.00	10.00



**R01**

The **R01** type rotary shaft seal has a metal inserts (Bonded) encased in rubber.



**R15**

The **R15** type rotary shaft seal has a metal encased on the outer diameter.



**R02**

The **R02** type rotary shaft seal is similar to R01 type but with an additional dust lip.

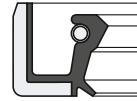

**R17**

The **R17** type rotary shaft seal is similar to R15 type but with an additional dust lip.

Max Spare Part No.	Shaft Dia.	Hsg. Dia.	Seal Ht.	Max Spare Part No.	Shaft Dia.	Hsg. Dia.	Seal Ht.
R020680811	68.00	90.00	10.00	R020700807	70.00	90.00	13.00
R010680809	68.00	90.00	12.00	R010700840	70.00	92.00	12.00
R010680805	68.00	90.00	13.00	R010700850	70.00	92.00	13.00
R010680823	68.00	95.00	10.00	R010700829	70.00	95.00	10.00
R010680807	68.00	100.00	10.00	R020700849	70.00	95.00	10.00
R010680825	68.00	100.00	12.00	R010700826	70.00	95.00	12.00
R010680833	68.00	100.00	13.00	R020700821	70.00	95.00	12.00
R010690856	69.82	79.75	9.52	R150700807	70.00	95.00	12.00
R010690857	69.85	88.39	12.70	R010700844	70.00	95.00	13.00
R010690840	69.85	88.90	9.52	R020700810	70.00	95.00	13.00
R020690802	69.85	88.90	9.52	R170700808	70.00	95.40	14.00
R010690832	69.85	88.90	12.70	R010700837	70.00	100.00	10.00
R010690845	69.85	95.25	9.52	R020700802	70.00	100.00	10.00
R010690858	69.85	95.25	12.70	R010700839	70.00	100.00	12.00
R010690846	69.85	95.85	12.70	R020700801	70.00	100.00	12.00
R0107008B7	70.00	80.00	6.00	R010700864	70.00	100.00	13.00
R010700848	70.00	80.00	10.00	R020700813	70.00	100.00	13.00
R010700816	70.00	85.00	6.00	R010700879	70.00	105.00	10.00
R010700809	70.00	85.00	7.00	R010700846	70.00	105.00	13.00
R010700802	70.00	85.00	8.00	R010700902	70.00	110.00	8.00
R020700806	70.00	85.00	8.00	R010700820	70.00	110.00	10.00
R150700816	70.00	85.00	8.00	R010700865	70.00	110.00	12.00
R010700835	70.00	85.00	10.00	R020700844	70.00	110.00	12.00
R020700804	70.00	85.00	10.00	R010700814	70.00	110.00	13.00
R010700877	70.00	86.00	8.00	R0107008B5	70.00	120.00	10.00
R010700878	70.00	88.00	8.00	R010700805	70.00	125.00	12.00
R020700839	70.00	88.00	12.00	R020700831	70.00	125.00	12.00
R010700807	70.00	90.00	7.00	R010720828	72.00	84.00	9.00
R010700866	70.00	90.00	8.00	R010720837	72.00	86.00	7.00
R020700864	70.00	90.00	8.00	R010720815	72.00	90.00	10.00
R010700803	70.00	90.00	10.00	R020720701	72.00	90.00	10.00
R020700818	70.00	90.00	10.00	R020720804	72.00	90.00	10.00
R150700801	70.00	90.00	10.00	R010720813	72.00	95.00	10.00
R170700802	70.00	90.00	10.00	R010720820	72.00	95.00	12.00
R010700801	70.00	90.00	12.00	R010720826	72.00	100.00	10.00
R020700843	70.00	90.00	12.00	R020720812	72.00	100.00	10.00
R010700804	70.00	90.00	13.00	R010720817	72.00	100.00	13.00



**R01**

The **R01** type rotary shaft seal has a metal inserts (Bonded) encased in rubber.



**R15**

The **R15** type rotary shaft seal has a metal encased on the outer diameter.



**R02**

The **R02** type rotary shaft seal is similar to R01 type but with an additional dust lip.

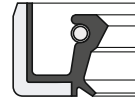

**R17**

The **R17** type rotary shaft seal is similar to R15 type but with an additional dust lip.

Max Spare Part No.	Shaft Dia.	Hsg. Dia.	Seal Ht.	Max Spare Part No.	Shaft Dia.	Hsg. Dia.	Seal Ht.
R010720805	72.00	105.00	13.00	R010750817	75.00	120.00	12.00
R010720832	72.00	110.00	13.00	R010750824	75.00	130.00	12.00
R010720852	72.00	140.00	12.00	R020750828	75.00	130.00	12.00
R010740811	74.00	95.00	10.00	R0107508D7	75.00	140.00	12.00
R010750841	75.00	85.00	10.00	R020750840	75.00	140.00	12.00
R010750801	75.00	90.00	8.00	R010760863	76.00	95.00	10.00
R020750804	75.00	90.00	8.00	R010760851	76.00	102.00	13.00
R010750802	75.00	90.00	10.00	R010760802	76.20	95.25	9.52
R020750829	75.00	90.00	10.00	R020760801	76.20	95.25	9.52
R010750807	75.00	95.00	8.00	R010760834	76.20	95.25	12.70
R020750857	75.00	95.00	8.00	R150760804	76.20	95.27	9.52
R010750835	75.00	95.00	10.00	R010760823	76.20	101.60	9.52
R020750812	75.00	95.00	10.00	R010760830	76.20	101.60	12.70
R150750806	75.00	95.00	10.00	R020760808	76.20	101.60	12.70
R010750804	75.00	95.00	12.00	R010760852	76.20	114.30	10.92
R020750838	75.00	95.00	12.00	R010760832	76.20	114.30	12.70
R010750805	75.00	95.00	13.00	R010780832	78.00	95.00	13.00
R020750810	75.00	95.00	13.00	R010780813	78.00	100.00	10.00
R010750806	75.00	100.00	10.00	R020780804	78.00	100.00	10.00
R020750809	75.00	100.00	10.00	R010780807	78.00	100.00	12.00
R150750802	75.00	100.00	10.00	R010780809	78.00	100.00	13.00
R170750801	75.00	100.00	10.00	R010780820	78.00	105.00	12.00
R010750829	75.00	100.00	12.00	R010780821	78.00	110.00	12.00
R020750830	75.00	100.00	12.00	R010800883	80.00	90.00	10.00
R150750812	75.00	100.00	12.00	R010800830	80.00	95.00	8.00
R010750803	75.00	100.00	13.00	R010800838	80.00	95.00	10.00
R020750823	75.00	100.00	13.00	R010800832	80.00	100.00	7.00
R010750813	75.00	105.00	10.00	R170800803	80.00	100.00	7.50
R010750812	75.00	105.00	12.00	R010800833	80.00	100.00	8.00
R010750851	75.00	105.00	13.00	R010800801	80.00	100.00	10.00
R020750821	75.00	105.00	13.00	R020800801	80.00	100.00	10.00
R010750808	75.00	110.00	10.00	R150800804	80.00	100.00	10.00
R010750819	75.00	110.00	12.00	R170800804	80.00	100.00	10.00
R010750811	75.00	115.00	10.00	R010800803	80.00	100.00	12.00
R020750811	75.00	115.00	10.00	R020800808	80.00	100.00	12.00
R010750823	75.00	115.00	12.00	R010800811	80.00	100.00	13.00
R010750899	75.00	115.00	13.00	R020800828	80.00	100.00	13.00

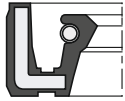

**R01**

The **R01** type rotary shaft seal has a metal inserts (Bonded) encased in rubber.



**R15**

The **R15** type rotary shaft seal has a metal encased on the outer diameter.



**R02**

The **R02** type rotary shaft seal is similar to R01 type but with an additional dust lip.



**R17**

The **R17** type rotary shaft seal is similar to R15 type but with an additional dust lip.

Max Spare Part No.	Shaft Dia.	Hsg. Dia.	Seal Ht.	Max Spare Part No.	Shaft Dia.	Hsg. Dia.	Seal Ht.
R150800803	80.00	100.00	13.00	R010820852	82.55	110.99	12.70
R010800812	80.00	100.00	15.00	R010820853	82.55	114.30	10.92
R010800822	80.00	105.00	10.00	R010820830	82.55	114.30	12.70
R010800815	80.00	105.00	12.00	R020820804	82.55	114.30	12.70
R020800825	80.00	105.00	12.00	R0108508C4	85.00	100.00	7.00
R010800802	80.00	105.00	13.00	R020850808	85.00	100.00	7.00
R020800803	80.00	105.00	13.00	R0108508C2	85.00	100.00	9.00
R010800820	80.00	110.00	10.00	R010850802	85.00	100.00	10.00
R020800824	80.00	110.00	10.00	R020850822	85.00	100.00	10.00
R150800801	80.00	110.00	10.00	R010850840	85.00	100.00	12.00
R010800821	80.00	110.00	12.00	R020850834	85.00	100.00	12.00
R020800816	80.00	110.00	12.00	R010850838	85.00	100.00	13.00
R010800805	80.00	110.00	13.00	R010850801.	85.00	105.00	10.00
R020800817	80.00	110.00	13.00	R020850804	85.00	105.00	10.00
R170800801	80.00	110.00	13.00	R150850817	85.00	105.00	10.00
R010800898	80.00	115.00	10.00	R010850836	85.00	105.00	12.00
R010800823	80.00	115.00	13.00	R020850824	85.00	105.00	12.00
R010800804	80.00	120.00	10.00	R010850803	85.00	105.00	13.00
R010800844	80.00	120.00	12.00	R150850818	85.00	105.00	13.00
R010800825	80.00	120.00	13.00	R010850853	85.00	110.00	10.00
R010800899	80.00	125.00	10.00	R020850833	85.00	110.00	10.00
R010800893	80.00	125.00	12.00	R010850889	85.00	110.00	11.00
R020800832	80.00	125.00	12.00	R020850801	85.00	110.00	11.00
R010800842	80.00	125.00	13.00	R010850815	85.00	110.00	12.00
R020800830	80.00	125.00	13.00	R020850806	85.00	110.00	12.00
R010800814	80.00	130.00	13.00	R020851006	85.00	110.00	12.00
R010800866	80.00	150.00	15.00	R170850802	85.00	110.00	12.00
R010810801	81.00	105.00	13.00	R010850831	85.00	110.00	13.00
R010820840	82.00	105.00	10.00	R020850803	85.00	110.00	13.00
R010820804	82.00	105.00	12.00	R010850856	85.00	110.00	15.00
R010820820	82.00	105.00	13.00	R020850839	85.00	110.00	15.00
R010820802	82.00	110.00	12.00	R150850807	85.00	110.00	12.00
R010820850	82.00	110.00	13.00	R010850805	85.00	115.00	10.00
R010820851	82.00	120.00	13.00	R010850816	85.00	115.00	12.00
R010820827	82.55	101.60	12.70	R010850827	85.00	115.00	13.00
R170820802	82.55	107.92	9.52	R010850813	85.00	120.00	10.00
R010820828	82.55	107.95	12.70	R010850817	85.00	120.00	12.00



**R01**

The **R01** type rotary shaft seal has a metal inserts (Bonded) encased in rubber.



**R15**

The **R15** type rotary shaft seal has a metal encased on the outer diameter.



**R02**

The **R02** type rotary shaft seal is similar to R01 type but with an additional dust lip.

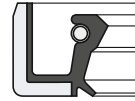

**R17**

The **R17** type rotary shaft seal is similar to R15 type but with an additional dust lip.

Max Spare Part No.	Shaft Dia.	Hsg. Dia.	Seal Ht.	Max Spare Part No.	Shaft Dia.	Hsg. Dia.	Seal Ht.
R020850811	85.00	120.00	12.00	R010900846	90.00	115.00	12.00
R010850847	85.00	120.00	13.00	R020900821	90.00	115.00	12.00
R020850810	85.00	120.00	13.00	R010900802	90.00	115.00	13.00
R0108508B4	85.00	130.00	10.00	R020900816	90.00	115.00	13.00
R020850809	85.00	130.00	10.00	R010900831	90.00	120.00	10.00
R010850811	85.00	130.00	12.00	R020900837	90.00	120.00	10.00
R020850828	85.00	130.00	12.00	R010900809	90.00	120.00	12.00
R010850891	85.00	130.00	13.00	R020900804	90.00	120.00	12.00
R010850804	85.00	140.00	12.00	R020902002	90.00	120.00	12.00
R0108508B6	85.00	140.00	13.00	R150900803	90.00	120.00	12.00
R010850857	85.00	150.00	12.00	R010900805	90.00	120.00	13.00
R010880846	88.00	105.00	10.00	R020900802	90.00	120.00	13.00
R010880857	88.00	110.00	10.00	R010900824	90.00	120.00	15.00
R010880835	88.90	114.30	9.52	R160900802	90.00	120.00	15.00
R010880822	88.90	114.30	12.70	R010900828	90.00	125.00	12.00
R020880810	88.90	114.30	12.70	R010900813	90.00	125.00	13.00
R010880801	88.90	127.00	12.70	R010900860	90.00	130.00	12.00
R010890810	89.00	127.00	13.00	R010900807	90.00	130.00	13.00
R010890811	89.90	114.30	9.52	R020900805	90.00	130.00	13.00
R010890812	89.90	114.30	10.92	R010900880	90.00	140.00	10.00
R010890813	89.90	120.65	15.75	R010900864	90.00	140.00	11.00
R010900845	90.00	100.00	10.00	R010900870	90.00	140.00	12.00
R010900819	90.00	105.00	10.00	R020900817	90.00	140.00	12.00
R010900858	90.00	105.00	13.00	R010900867	90.00	140.00	13.00
R010900804	90.00	110.00	8.00	R0109008A7	90.00	170.00	12.00
R010900814	90.00	110.00	10.00	R010920802	92.00	110.00	12.00
R020900818	90.00	110.00	10.00	R010920822	92.00	120.00	12.00
R150900821	90.00	110.00	10.00	R010920819	92.00	120.00	13.00
R010900803	90.00	110.00	12.00	R170950802	95.00	110.00	7.00
R020900801	90.00	110.00	12.00	R010950801	95.00	110.00	10.00
R150900807	90.00	110.00	12.00	R010950822	95.00	110.00	12.00
R170900807	90.00	110.00	12.00	R010950824	95.00	110.00	13.00
R010900827	90.00	110.00	13.00	R010950833	95.00	115.00	10.00
R020900807	90.00	110.00	13.00	R010950813	95.00	115.00	12.00
R150900819	90.00	110.00	13.00	R010950849	95.00	115.00	13.00
R010900822	90.00	115.00	9.00	R020950813	95.00	115.00	13.00
R010900801	90.00	115.00	10.00	R010950832	95.00	120.00	10.00

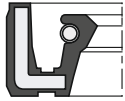

**R01**

The **R01** type rotary shaft seal has a metal inserts (Bonded) encased in rubber.



**R15**

The **R15** type rotary shaft seal has a metal encased on the outer diameter.



**R02**

The **R02** type rotary shaft seal is similar to R01 type but with an additional dust lip.

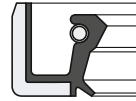

**R17**

The **R17** type rotary shaft seal is similar to R15 type but with an additional dust lip.

Max Spare Part No.	Shaft Dia.	Hsg. Dia.	Seal Ht.	Max Spare Part No.	Shaft Dia.	Hsg. Dia.	Seal Ht.
R010950802	95.00	120.00	12.00	R011000801	100.00	125.00	12.00
R020950804	95.00	120.00	12.00	R021000813	100.00	125.00	12.00
R150950805	95.00	120.00	12.00	R021002002	100.00	125.00	12.00
R010950803	95.00	120.00	13.00	R151000804	100.00	125.00	12.00
R020950812	95.00	120.00	13.00	R011000803	100.00	125.00	13.00
R150950806	95.00	120.00	13.00	R021000811	100.00	125.00	13.00
R010950829	95.00	120.00	15.00	R151000813	100.00	125.00	13.00
R010950831	95.00	125.00	10.00	R011000897	100.00	127.00	13.00
R010950837	95.00	125.00	12.00	R011000840	100.00	130.00	10.00
R020950806	95.00	125.00	12.00	R011000804	100.00	130.00	12.00
R150950826	95.00	125.00	12.00	R021000804	100.00	130.00	12.00
R170950801	95.00	125.00	12.00	R151000810	100.00	130.00	12.00
R010950814	95.00	125.00	13.00	R011000831	100.00	130.00	13.00
R020950803	95.00	125.00	13.00	R021000807	100.00	130.00	13.00
R010950820	95.00	130.00	12.00	R0110008A4	100.00	130.00	15.00
R020950829	95.00	130.00	12.00	R021000801	100.00	130.00	15.00
R010950835	95.00	130.00	13.00	R011000854	100.00	135.00	12.00
R010950863	95.00	135.00	10.00	R011000817	100.00	135.00	15.00
R010950887	95.00	145.00	10.00	R011000815	100.00	140.00	12.00
R020950809	95.00	145.00	10.00	R011000812	100.00	140.00	13.00
R010950868	95.00	145.00	13.00	R011000842	100.00	150.00	12.00
R010950857	95.00	170.00	13.00	R021000821	100.00	150.00	12.00
R020950811	95.00	170.00	13.00	R011000859	100.00	150.00	13.00
R010950847	95.25	120.65	12.70	R011010808	101.60	127.00	12.70
R010980820	98.00	120.00	10.00	R011010801	101.60	133.35	12.70
R010980807	98.00	120.00	13.00	R011020808	102.00	125.00	14.00
R011000836	100.00	115.00	9.00	R171050803	105.00	120.00	8.00
R011000833	100.00	120.00	8.00	R011050837	105.00	120.00	12.00
R011000820	100.00	120.00	10.00	R011050815	105.00	125.00	10.00
R021000805	100.00	120.00	10.00	R011050818	105.00	125.00	12.00
R011000805	100.00	120.00	12.00	R011050811	105.00	125.00	13.00
R021000814	100.00	120.00	12.00	R011050819	105.00	130.00	10.00
R151000809	100.00	120.00	12.00	R011050801	105.00	130.00	12.00
R011000829	100.00	120.00	13.00	R021050801	105.00	130.00	12.00
R021000822	100.00	120.00	13.00	R151050801	105.00	130.00	12.00
R011000862	100.00	125.00	10.00	R171050802	105.00	130.00	12.00
R021000830	100.00	125.00	10.00	R011050803	105.00	130.00	13.00



**R01**

The **R01** type rotary shaft seal has a metal inserts (Bonded) encased in rubber.



**R15**

The **R15** type rotary shaft seal has a metal encased on the outer diameter.



**R02**

The **R02** type rotary shaft seal is similar to R01 type but with an additional dust lip.



**R17**

The **R17** type rotary shaft seal is similar to R15 type but with an additional dust lip.

Max Spare Part No.	Shaft Dia.	Hsg. Dia.	Seal Ht.	Max Spare Part No.	Shaft Dia.	Hsg. Dia.	Seal Ht.
R021050808	105.00	130.00	13.00	R011100804	110.00	140.00	14.00
R011050804	105.00	130.00	15.00	R021100804	110.00	140.00	14.00
R011050807	105.00	135.00	12.00	R011100832	110.00	140.00	15.00
R011050810	105.00	135.00	13.00	R151100807	110.00	140.00	15.00
R011050821	105.00	135.00	14.00	R011100875	110.00	150.00	12.00
R011050805	105.00	140.00	12.00	R011100821	110.00	150.00	13.00
R021050809	105.00	140.00	12.00	R011100819	110.00	150.00	15.00
R011050814	105.00	140.00	13.00	R021100817	110.00	170.00	15.00
R011050808	105.00	140.00	15.00	R021100813	110.00	200.00	15.00
R011050825	105.00	150.00	15.00	R011120804	112.00	140.00	13.00
R011050832	105.00	160.00	12.00	R011120815	112.00	150.00	25.00
R021050806	105.00	160.00	12.00	R011140841	114.00	140.00	13.00
R011050861	105.00	170.00	15.00	R021140804	114.30	139.70	12.70
R011070812	107.95	133.35	12.70	R011140843	114.30	158.80	15.00
R011100837	110.00	128.00	9.00	R011150847	115.00	135.00	10.00
R011100810	110.00	130.00	8.00	R011150801	115.00	140.00	12.00
R011100831	110.00	130.00	10.00	R021150802	115.00	140.00	12.00
R021100820	110.00	130.00	10.00	R151150801	115.00	140.00	12.00
R011100826	110.00	130.00	12.00	R011150802	115.00	140.00	13.00
R021100809	110.00	130.00	12.00	R021150803	115.00	140.00	13.00
R171100801	110.00	130.00	12.00	R151150802	115.00	140.00	13.00
R151100803	110.00	130.00	12.00	R011150842	115.00	140.00	14.00
R011100803	110.00	130.00	13.00	R011150817	115.00	140.00	15.00
R021100808	110.00	130.00	13.00	R021150852	115.00	140.00	15.00
R151100801	110.00	130.00	13.00	R011150822	115.00	140.00	16.00
R011100802	110.00	130.00	15.00	R011150823	115.00	145.00	13.00
R011100811	110.00	135.00	12.00	R011150829	115.00	145.00	14.00
R011100806	110.00	135.00	13.00	R021150806	115.00	145.00	14.00
R011100855	110.00	136.00	10.00	R011150818	115.00	145.00	15.00
R011100870	110.00	140.00	10.00	R011150816	115.00	150.00	12.00
R021100822	110.00	140.00	10.00	R021150809	115.00	150.00	12.00
R011100801	110.00	140.00	12.00	R011150845	115.00	150.00	13.00
R021100807	110.00	140.00	12.00	R011150804	115.00	150.00	15.00
R151100808	110.00	140.00	12.00	R011150830	115.00	152.00	12.00
R011100808	110.00	140.00	13.00	R011180801	118.00	150.00	12.00
R021100801	110.00	140.00	13.00	R021180801	118.00	150.00	12.00
R151100804	110.00	140.00	13.00	R021180803	118.00	150.00	14.00



**R01**

The **R01** type rotary shaft seal has a metal inserts (Bonded) encased in rubber.



**R15**

The **R15** type rotary shaft seal has a metal encased on the outer diameter.



**R02**

The **R02** type rotary shaft seal is similar to R01 type but with an additional dust lip.

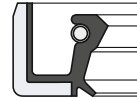

**R17**

The **R17** type rotary shaft seal is similar to R15 type but with an additional dust lip.

Max Spare Part No.	Shaft Dia.	Hsg. Dia.	Seal Ht.	Max Spare Part No.	Shaft Dia.	Hsg. Dia.	Seal Ht.
R011200831	120.00	140.00	10.00	R011250802	125.00	150.00	15.00
R021200833	120.00	140.00	10.00	R011250836	125.00	155.00	12.00
R011200839	120.00	140.00	12.00	R011250835	125.00	155.00	14.00
R011200802	120.00	140.00	13.00	R011250821	125.00	160.00	12.00
R021200808	120.00	140.00	13.00	R021250801	125.00	160.00	12.00
R011200855	120.00	140.00	15.00	R011250818	125.00	160.00	13.00
R011200853	120.00	145.00	13.00	R021250803	125.00	160.00	13.00
R011200850	120.00	150.00	7.00	R011250814	125.00	160.00	15.00
R011200805	120.00	150.00	10.00	R011270802	127.00	152.40	12.70
R011200804	120.00	150.00	12.00	R011270833	127.00	178.00	13.00
R021200807	120.00	150.00	12.00	R011300847	130.00	150.00	7.50
R151200802	120.00	150.00	12.00	R011300820	130.00	150.00	10.00
R171200807	120.00	150.00	12.00	R021300802	130.00	150.00	10.00
R011200803	120.00	150.00	13.00	R011300827	130.00	150.00	12.00
R021200802	120.00	150.00	13.00	R021300814	130.00	150.00	12.00
R151200806	120.00	150.00	13.00	R011300821	130.00	150.00	13.00
R011200848	120.00	150.00	14.00	R021300804	130.00	150.00	13.00
R021200801	120.00	150.00	14.00	R011300802	130.00	150.00	15.00
R171200810	120.00	150.00	14.00	R011300845	130.00	152.00	14.00
R011200801	120.00	150.00	15.00	R011300819	130.00	155.00	10.00
R021200805	120.00	150.00	15.00	R011300814	130.00	155.00	13.00
R171200806	120.00	160.00	10.00	R011300878	130.00	156.00	12.00
R011200832	120.00	160.00	12.00	R011300801	130.00	160.00	12.00
R021200812	120.00	160.00	12.00	R021300813	130.00	160.00	12.00
R011200822	120.00	160.00	13.00	R151300805	130.00	160.00	12.00
R021200806	120.00	160.00	13.00	R171300802	130.00	160.00	12.00
R011200870	120.00	160.00	14.00	R011300813	130.00	160.00	13.00
R011200840	120.00	160.00	15.00	R021300805	130.00	160.00	13.00
R011200896	120.00	180.00	12.00	R011300804	130.00	160.00	14.00
R011200815	120.00	180.00	15.00	R021300812	130.00	160.00	14.00
R011250808	125.00	145.00	10.00	R011300803	130.00	160.00	15.00
R011250803	125.00	145.00	13.00	R021300801	130.00	160.00	15.00
R011250820	125.00	150.00	12.00	R151300803	130.00	160.00	15.00
R021250811	125.00	150.00	12.00	R011300846	130.00	162.00	14.00
R151250810	125.00	150.00	12.00	R011300830	130.00	170.00	12.00
R011250825	125.00	150.00	13.00	R011300822	130.00	170.00	15.00
R021250810	125.00	150.00	13.00	R021300818	130.00	200.00	12.00

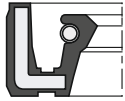

**R01**

The **R01** type rotary shaft seal has a metal inserts (Bonded) encased in rubber.

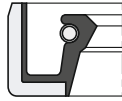

**R15**

The **R15** type rotary shaft seal has a metal encased on the outer diameter.



**R02**

The **R02** type rotary shaft seal is similar to R01 type but with an additional dust lip.

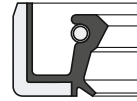

**R17**

The **R17** type rotary shaft seal is similar to R15 type but with an additional dust lip.

Max Spare Part No.	Shaft Dia.	Hsg. Dia.	Seal Ht.	Max Spare Part No.	Shaft Dia.	Hsg. Dia.	Seal Ht.
R011300881	130.00	200.00	15.00	R011400854	140.00	210.00	15.00
R011330820	133.35	158.75	14.35	R011450810	145.00	165.00	13.00
R011350812	135.00	160.00	12.00	R011450832	145.00	167.00	13.00
R011350818	135.00	160.00	13.00	R011450836	145.00	170.00	13.00
R021350802	135.00	160.00	15.00	R011450820	145.00	170.00	15.00
R011350822	135.00	165.00	12.00	R011450819	145.00	175.00	12.00
R011350814	135.00	165.00	14.00	R011450813	145.00	175.00	13.00
R021350809	135.00	165.00	14.00	R011450812	145.00	175.00	15.00
R011350802	135.00	165.00	15.00	R021450809	145.00	175.00	15.00
R171350801	135.00	170.00	10.00	R011450805	145.00	180.00	13.00
R011350807	135.00	170.00	12.00	R011450802	145.00	180.00	15.00
R021350804	135.00	170.00	12.00	R011460811	146.05	177.80	12.70
R011350813	135.00	170.00	13.00	R011500849	150.00	170.00	10.00
R011350817	135.00	170.00	15.00	R011500810	150.00	170.00	12.00
R151390806	139.70	171.45	12.70	R011500821	150.00	170.00	13.00
R011400806	140.00	160.00	10.00	R011500813	150.00	170.00	15.00
R011400823	140.00	160.00	12.00	R011500836	150.00	175.00	13.00
R021400803	140.00	160.00	12.00	R011500803	150.00	180.00	12.00
R011400822	140.00	160.00	13.00	R021500816	150.00	180.00	12.00
R011400807	140.00	165.00	13.00	R011500817	150.00	180.00	13.00
R011400817	140.00	170.00	12.00	R021500806	150.00	180.00	13.00
R021400815	140.00	170.00	12.00	R011500804	150.00	180.00	14.00
R151400808	140.00	170.00	12.00	R021500818	150.00	180.00	14.00
R011400820	140.00	170.00	13.00	R011500801	150.00	180.00	15.00
R021400802	140.00	170.00	13.00	R021500801	150.00	180.00	15.00
R011400826	140.00	170.00	14.00	R151500805	150.00	180.00	15.00
R021400812	140.00	170.00	14.00	R171500801	150.00	180.00	15.00
R151400811	140.00	170.00	14.00	R011500830	150.00	180.00	16.00
R011400801	140.00	170.00	15.00	R011500822	150.00	190.00	13.00
R021400805	140.00	170.00	15.00	R011500819	150.00	190.00	15.00
R151400801	140.00	170.00	15.00	R011500850	150.00	225.00	15.00
R011400816	140.00	170.00	16.00	R011520812	152.40	171.45	11.94
R021400819	140.00	170.00	16.00	R011520806	152.40	177.80	12.70
R011400847	140.00	175.00	15.00	R011550802	155.00	174.00	12.00
R011400839	140.00	175.00	16.00	R011550807	155.00	180.00	13.00
R011400803	140.00	180.00	15.00	R011550809	155.00	180.00	15.00
R011400835	140.00	190.00	15.00	R171550804	155.00	180.00	15.00



**R01**

The **R01** type rotary shaft seal has a metal inserts (Bonded) encased in rubber.



**R15**

The **R15** type rotary shaft seal has a metal encased on the outer diameter.



**R02**

The **R02** type rotary shaft seal is similar to R01 type but with an additional dust lip.

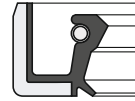

**R17**

The **R17** type rotary shaft seal is similar to R15 type but with an additional dust lip.

Max Spare Part No.	Shaft Dia.	Hsg. Dia.	Seal Ht.	Max Spare Part No.	Shaft Dia.	Hsg. Dia.	Seal Ht.
R011550819	155.00	185.00	15.00	R011700832	170.00	200.00	16.00
R011550822	155.00	190.00	13.00	R021700815	170.00	200.00	16.00
R171550801	155.00	190.00	15.00	R011700813	170.00	210.00	15.00
R011560801	156.00	186.00	15.00	R011700821	170.00	220.00	15.00
R011590803	159.00	183.00	13.00	R171700804	170.00	200.00	15.00
R011600810	160.00	180.00	10.00	R011750806	175.00	200.00	12.00
R021600802	160.00	180.00	10.00	R011750810	175.00	200.00	13.00
R011600806	160.00	180.00	13.00	R011750807	175.00	200.00	15.00
R011600815	160.00	180.00	15.00	R021750802	175.00	200.00	15.00
R011600812	160.00	185.00	10.00	R011750809	175.00	205.00	13.00
R011600817	160.00	185.00	13.00	R011750817	175.00	205.00	15.00
R011600809	160.00	185.00	15.00	R021750803	175.00	205.00	15.00
R011600807	160.00	190.00	10.00	R011750804	175.00	210.00	15.00
R021600807	160.00	190.00	10.00	R011800812	180.00	200.00	12.00
R011600846	160.00	190.00	12.00	R011800814	180.00	200.00	15.00
R011600811	160.00	190.00	13.00	R011800813	180.00	210.00	13.00
R021600804	160.00	190.00	13.00	R011800829	180.00	210.00	14.00
R011600801	160.00	190.00	15.00	R011800803	180.00	210.00	15.00
R021600801	160.00	190.00	15.00	R021800817	180.00	210.00	15.00
R151600802	160.00	190.00	15.00	R151800805	180.00	210.00	15.00
R011600820	160.00	190.00	16.00	R011800825	180.00	210.00	16.00
R011600814	160.00	200.00	12.00	R011800807	180.00	215.00	15.00
R011600816	160.00	200.00	15.00	R011800817	180.00	215.00	16.00
R011600831	160.00	200.00	16.00	R021800818	180.00	215.00	16.00
R011650820	165.00	190.00	13.00	R011800826	180.00	220.00	15.00
R021650802	165.00	190.00	13.00	R011800811	180.00	220.00	16.00
R011650823	165.00	190.00	15.00	R021800833	180.00	220.00	16.00
R021650805	165.00	190.00	15.00	R011800840	180.00	220.00	18.00
R011650822	165.00	195.00	15.00	R021840802	184.00	214.00	10.00
R011650840	165.00	200.00	15.00	R011850807	185.00	210.00	13.00
R011700841	170.00	190.00	10.00	R011900829	190.00	215.00	15.00
R011700815	170.00	200.00	12.00	R011900826	190.00	215.00	16.00
R011700806	170.00	200.00	13.00	R011900806	190.00	220.00	12.00
R021700816	170.00	200.00	13.00	R021900802	190.00	220.00	12.00
R011700809	170.00	200.00	15.00	R011900807	190.00	220.00	13.00
R021700801	170.00	200.00	15.00	R011900810	190.00	220.00	15.00
R151700801	170.00	200.00	15.00	R021900803	190.00	220.00	15.00



**R01**

The **R01** type rotary shaft seal has a metal inserts (Bonded) encased in rubber.



**R15**

The **R15** type rotary shaft seal has a metal encased on the outer diameter.



**R02**

The **R02** type rotary shaft seal is similar to R01 type but with an additional dust lip.

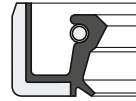

**R17**

The **R17** type rotary shaft seal is similar to R15 type but with an additional dust lip.

Max Spare Part No.	Shaft Dia.	Hsg. Dia.	Seal Ht.	Max Spare Part No.	Shaft Dia.	Hsg. Dia.	Seal Ht.
R151900803	190.00	220.00	15.00	R012200814	220.00	250.00	13.00
R011900814	190.00	220.00	16.00	R012200805	220.00	250.00	15.00
R011900801	190.00	225.00	16.00	R022200802	220.00	250.00	15.00
R011900819	190.00	230.00	15.00	R012200801	220.00	250.00	16.00
R011900848	190.00	230.00	16.00	R022200814	220.00	250.00	16.00
R011950809	195.00	220.00	16.00	R152200809	220.00	250.00	16.00
R011950815	195.00	230.00	15.00	R012200804	220.00	260.00	15.00
R012000865	200.00	220.00	12.00	R012200827	220.00	260.00	16.00
R012000853	200.00	225.00	15.00	R012200837	220.00	260.00	18.00
R012000850	200.00	230.00	12.00	R022250801	225.00	250.00	12.00
R012000803	200.00	230.00	13.00	R012250809	225.00	250.00	16.00
R012000806	200.00	230.00	15.00	R012300806	230.00	260.00	15.00
R022000802	200.00	230.00	15.00	R022300801	230.00	260.00	15.00
R012000846	200.00	230.00	18.00	R152300805	230.00	260.00	15.00
R012000808	200.00	235.00	18.00	R012300823	230.00	260.00	16.00
R012000819	200.00	240.00	15.00	R012300808	230.00	270.00	15.00
R022000801	200.00	240.00	15.00	R012400819	240.00	265.00	15.00
R012000838	200.00	240.00	16.00	R012400814	240.00	270.00	7.00
R012000840	200.00	240.00	18.00	R022400802	240.00	270.00	13.00
R012000835	200.00	240.00	20.00	R012400802	240.00	270.00	15.00
R012000822	200.00	250.00	15.00	R022400808	240.00	270.00	15.00
R012050802	205.00	230.00	16.00	R152400801	240.00	270.00	15.00
R012050805	205.00	235.00	15.00	R012400809	240.00	270.00	16.00
R012100829	210.00	230.00	13.00	R012400801	240.00	280.00	15.00
R012100827	210.00	240.00	10.00	R012400805	240.00	280.00	16.00
R022100803	210.00	240.00	12.00	R012450803	245.00	265.00	10.00
R012100801	210.00	240.00	15.00	R012450802	245.00	270.00	16.00
R022100802	210.00	240.00	15.00	R012500805	250.00	280.00	15.00
R152100803	210.00	240.00	15.00	R022500801	250.00	280.00	15.00
R012100809	210.00	250.00	15.00	R152500813	250.00	280.00	15.00
R012100803	210.00	250.00	16.00	R172500802	250.00	285.00	18.00
R012150807	215.00	240.00	12.00	R012500815	250.00	290.00	15.00
R012150826	215.00	245.00	15.00	R012500802	250.00	290.00	16.00
R022150807	215.00	248.00	15.00	R012600815	260.00	280.00	16.00
R012150817	215.00	248.00	15.00	R012600802	260.00	285.00	12.00
R012150818	215.00	250.00	15.00	R012600810	260.00	290.00	15.00
R012200840	220.00	240.00	15.00	R022600806	260.00	290.00	15.00



**R01**

The **R01** type rotary shaft seal has a metal inserts (Bonded) encased in rubber.



**R15**

The **R15** type rotary shaft seal has a metal encased on the outer diameter.



**R02**

The **R02** type rotary shaft seal is similar to R01 type but with an additional dust lip.

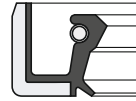

**R17**

The **R17** type rotary shaft seal is similar to R15 type but with an additional dust lip.

Max Spare Part No.	Shaft Dia.	Hsg. Dia.	Seal Ht.	Max Spare Part No.	Shaft Dia.	Hsg. Dia.	Seal Ht.
R012600808	260.00	290.00	16.00	R013000819	300.00	330.00	15.00
R022600802	260.00	290.00	16.00	R023000810	300.00	330.00	15.00
R152600803	260.00	290.00	16.00	R013000807	300.00	335.00	15.00
R012600807	260.00	300.00	15.00	R013000805	300.00	340.00	16.00
R022600803	260.00	300.00	15.00	R013000816	300.00	340.00	18.00
R012600832	260.00	300.00	18.00	R023000801	300.00	340.00	18.00
R012600801	260.00	300.00	20.00	R153000802	300.00	340.00	18.00
R022600801	260.00	300.00	20.00	R013000801	300.00	340.00	20.00
R152600801	260.00	300.00	20.00	R023000803	300.00	340.00	20.00
R012600840	260.00	320.00	15.00	R153000809	300.00	340.00	20.00
R012650809	265.00	290.00	16.00	R013100806	310.00	340.00	15.00
R012700810	270.00	300.00	15.00	R013100807	310.00	350.00	15.00
R012700802	270.00	310.00	16.00	R013100805	310.00	350.00	18.00
R012700814	270.00	310.00	18.00	R013150804	315.00	345.00	15.00
R012700813	270.00	310.00	20.00	R013200805	320.00	350.00	15.00
R012750811	275.00	310.00	15.00	R013200813	320.00	350.00	18.00
R022750802	275.00	310.00	15.00	R013200807	320.00	360.00	15.00
R012750808	275.00	315.00	15.00	R013200810	320.00	360.00	17.00
R012750814	275.00	315.00	18.00	R013200802	320.00	360.00	18.00
R012800804	280.00	310.00	15.00	R023200808	320.00	360.00	18.00
R022800808	280.00	310.00	15.00	R013200801	320.00	360.00	20.00
R012800802	280.00	310.00	16.00	R023200801	320.00	360.00	20.00
R022800802	280.00	310.00	16.00	R153200802	320.00	360.00	20.00
R012800835	280.00	318.00	15.00	R013200815	320.00	364.00	20.00
R012800819	280.00	320.00	15.00	R013300812	330.00	370.00	20.00
R152800819	280.00	320.00	15.00	R013400802	340.00	380.00	15.00
R012800807	280.00	320.00	18.00	R013400810	340.00	380.00	18.00
R152800808	280.00	320.00	18.00	R013400801	340.00	380.00	20.00
R012800808	280.00	320.00	20.00	R013500804	350.00	380.00	15.00
R022800801	280.00	320.00	20.00	R013500803	350.00	390.00	18.00
R012850806	285.00	310.00	15.00	R013550801	355.00	390.00	20.00
R012900807	290.00	320.00	15.00	R013600802	360.00	400.00	18.00
R012900817	290.00	325.00	18.00	R013600801	360.00	400.00	20.00
R012900805	290.00	330.00	18.00	R023600802	360.00	400.00	20.00
R012900802	290.00	330.00	20.00	R013700802	370.00	410.00	20.00
R012950804	295.00	325.00	16.00	R013800801	380.00	420.00	20.00



**R01**

The **R01** type rotary shaft seal has a metal inserts (Bonded) encased in rubber.



**R15**

The **R15** type rotary shaft seal has a metal encased on the outer diameter.



**R02**

The **R02** type rotary shaft seal is similar to R01 type but with an additional dust lip.

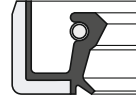

**R17**

The **R17** type rotary shaft seal is similar to R15 type but with an additional dust lip.

Max Spare Part No.	Shaft Dia.	Hsg. Dia.	Seal Ht.	Max Spare Part No.	Shaft Dia.	Hsg. Dia.	Seal Ht.
R013800805	380.00	420.00	18.00	R014400802	440.00	480.00	20.00
R023800804	380.00	420.00	20.00	R014500807	450.00	490.00	20.00
R013900806	390.00	430.00	18.00	R014600802	460.00	500.00	20.00
R013900812	390.00	440.00	20.00	R014800801	480.00	520.00	20.00
R014000801	400.00	440.00	20.00	R025000802	500.00	540.00	20.00
R024000801	400.00	440.00	20.00	R015400803	540.00	580.00	20.00
R014200801	420.00	460.00	20.00				



**R01**

The **R01** type rotary shaft seal has a metal inserts (Bonded) encased in rubber.



**R02**

The **R02** type rotary shaft seal is similar to R01 type but with an additional dust lip.

Max Spare Part No.	Shaft Dia.	Hsg. Dia.	Seal Ht.	Max Spare Part No.	Shaft Dia.	Hsg. Dia.	Seal Ht.
R010066407	6.00	14.00	6.00	R020206411	20.00	30.00	6.00
R020086407	8.00	18.00	5.00	R010206404	20.00	30.00	7.00
R020086408	8.00	19.00	7.00	R020206408	20.00	30.00	7.00
R010086403	8.00	22.00	7.00	R010206406	20.00	32.00	7.00
R010126465	12.00	21.00	7.00	R020206414	20.00	32.00	7.00
R010126416	12.00	22.00	4.00	R010206422	20.00	32.00	8.00
R010126402	12.00	22.00	7.00	R010206426	20.00	35.00	6.00
R020126404	12.00	22.00	7.00	R010206405	20.00	35.00	7.00
R010126431	12.00	22.00	8.00	R020206404	20.00	35.00	7.00
R010126428	12.00	24.00	7.00	R010206424	20.00	40.00	7.00
R010126462	12.00	25.00	6.00	R010206430	20.00	42.00	7.00
R020126417	12.00	28.00	5.00	R010226407	22.00	32.00	7.00
R010126424	12.70	21.44	6.35	R010226409	22.00	35.00	7.00
R010146403	14.00	24.00	7.00	R020226407	22.00	35.00	7.00
R010146409	14.00	28.00	7.00	R010226463	22.00	35.00	8.00
R010156403	15.00	24.00	7.00	R010226421	22.00	35.00	10.00
R020156420	15.00	25.00	5.00	R010226402	22.00	40.00	7.00
R010156415	15.00	30.00	7.00	R010246409	24.00	35.00	7.00
R020156407	15.00	30.00	7.00	R020246404	24.00	40.00	8.00
R010156401	15.00	35.00	7.00	R010246414	24.00	42.00	8.00
R0101564B6	15.00	35.00	10.00	R020256422	25.00	35.00	6.00
R010166404	16.00	28.00	7.00	R010256402	25.00	35.00	7.00
R010166407	16.00	28.00	10.00	R020256401	25.00	35.00	7.00
R010166423	16.00	30.00	7.00	R010256413	25.00	37.00	7.00
R010166412	16.00	32.00	10.00	R010256446	25.00	38.00	7.00
R010166418	16.00	35.00	7.00	R010256451	25.00	38.00	8.00
R010176402	17.00	28.00	7.00	R010256449	25.00	40.00	5.00
R010176403	17.00	30.00	7.00	R010256416	25.00	40.00	7.00
R020176405	17.00	30.00	7.00	R020256419	25.00	40.00	7.00
R010176416	17.00	35.00	7.00	R010256439	25.00	40.00	8.00
R010186404	18.00	30.00	7.00	R010256421	25.00	40.00	10.00
R020186401	18.00	30.00	7.00	R010256443	25.00	42.00	6.00
R010186410	18.00	32.00	7.00	R010256409	25.00	42.00	7.00
R010196414	19.00	30.00	7.00	R020256426	25.00	42.00	7.00
R020196406	19.00	30.00	7.00	R010256482	25.00	42.00	8.00
R020196405	19.00	35.00	7.00	R010256425	25.00	42.00	10.00
R010206415	20.00	30.00	5.00	R020256433	25.00	45.00	10.00



**R01**

The **R01** type rotary shaft seal has a metal inserts (Bonded) encased in rubber.



**R02**

The **R02** type rotary shaft seal is similar to R01 type but with an additional dust lip.

Max Spare Part No.	Shaft Dia.	Hsg. Dia.	Seal Ht.	Max Spare Part No.	Shaft Dia.	Hsg. Dia.	Seal Ht.
R010256453	25.00	47.00	6.00	R010306440	30.00	62.00	7.00
R010256405	25.00	47.00	7.00	R020306413	30.00	62.00	7.00
R010256412	25.00	47.00	10.00	R010306450	30.00	62.00	8.00
R010256403	25.00	52.00	7.00	R010306444	30.00	72.00	8.00
R020256409	25.00	52.00	7.00	R010326403	32.00	45.00	7.00
R010256474	25.00	52.00	10.00	R020326409	32.00	45.00	7.00
R010256462	25.00	62.00	7.50	R020326416	32.00	47.00	6.00
R010256479	25.00	62.00	8.00	R010326402	32.00	47.00	7.00
R010286422	28.00	38.00	7.00	R010326410	32.00	52.00	7.00
R010286402	28.00	40.00	7.00	R020326402	32.00	52.00	7.00
R010286410	28.00	42.00	7.00	R020326406	32.00	52.00	10.00
R010286416	28.00	47.00	10.00	R010356441	35.00	45.00	7.00
R010286440	28.00	50.00	7.00	R020356443	35.00	45.00	7.00
R010306468	30.00	40.00	5.00	R010356454	35.00	47.00	6.00
R010306403	30.00	40.00	7.00	R010356401	35.00	47.00	7.00
R020306406	30.00	40.00	7.00	R020356434	35.00	47.00	7.00
R010306409	30.00	42.00	7.00	R010356438	35.00	47.00	8.00
R020306402	30.00	42.00	7.00	R010356432	35.00	47.00	10.00
R010306435	30.00	42.00	10.00	R010356453	35.00	48.00	7.00
R010306419	30.00	45.00	7.00	R010356407	35.00	50.00	7.00
R020306410	30.00	45.00	7.00	R020356401	35.00	50.00	7.00
R010306442	30.00	45.00	8.00	R010356446	35.00	50.00	8.00
R010306405	30.00	47.00	7.00	R020356448	35.00	50.00	8.00
R020306408	30.00	47.00	7.00	R020356456	35.00	50.00	10.00
R010306430	30.00	47.00	10.00	R010356404	35.00	52.00	7.00
R010306458	30.00	50.00	7.00	R020356435	35.00	52.00	7.00
R020306444	30.00	50.00	7.00	R010356421	35.00	52.00	8.00
R010306470	30.00	50.00	8.00	R010356406	35.00	52.00	10.00
R010306402	30.00	50.00	10.00	R020356459	35.00	55.00	7.00
R010306433	30.00	52.00	5.00	R010356413	35.00	55.00	8.00
R020306439	30.00	52.00	5.00	R010356426	35.00	55.00	10.00
R010306410	30.00	52.00	7.00	R010356460	35.00	55.00	11.00
R020306403	30.00	52.00	7.00	R020356436	35.00	56.00	10.00
R010306436	30.00	52.00	8.00	R010356440	35.00	56.00	12.00
R010306401	30.00	52.00	10.00	R010356448	35.00	60.00	10.00
R020306414	30.00	52.00	10.00	R020356445	35.00	60.00	12.00
R010306461	30.00	55.00	7.00	R010356433	35.00	62.00	7.00



**R01**

The **R01** type rotary shaft seal has a metal inserts (Bonded) encased in rubber.



**R02**

The **R02** type rotary shaft seal is similar to R01 type but with an additional dust lip.

Max Spare Part No.	Shaft Dia.	Hsg. Dia.	Seal Ht.	Max Spare Part No.	Shaft Dia.	Hsg. Dia.	Seal Ht.
R010356439	35.00	72.00	10.00	R020406414	40.00	80.00	10.00
R020356440	35.00	72.00	10.00	R010426402	42.00	55.00	8.00
R010356466	35.00	72.00	12.00	R020426406	42.00	55.00	8.00
R020366411	36.00	52.00	7.00	R010426401	42.00	62.00	8.00
R010386423	38.00	50.00	7.00	R020426416	42.00	62.00	8.00
R010386440	38.00	52.00	7.00	R010426404	42.00	63.00	9.00
R010386424	38.00	55.00	7.00	R020426405	42.00	63.00	9.00
R010406408	40.00	50.00	7.00	R010426416	42.00	65.00	10.00
R020406426	40.00	50.00	7.00	R010426443	42.00	72.00	10.00
R010406431	40.00	50.00	8.00	R010446404	44.45	63.50	9.52
R010406404	40.00	52.00	7.00	R020446402	44.45	63.50	9.52
R020406416	40.00	52.00	7.00	R010456448	45.00	55.00	10.00
R010406458	40.00	52.00	8.00	R010456404	45.00	60.00	7.00
R010406443	40.00	52.00	10.00	R020456413	45.00	60.00	7.00
R010406433	40.00	55.00	7.00	R010456403	45.00	60.00	8.00
R020406409	40.00	55.00	7.00	R020456426	45.00	60.00	8.00
R010406415	40.00	55.00	8.00	R010456401	45.00	60.00	10.00
R010406439	40.00	55.00	10.00	R010456407	45.00	62.00	7.00
R020406428	40.00	55.00	10.00	R020456419	45.00	62.00	7.00
R020406411	40.00	58.00	8.00	R010456402	45.00	62.00	8.00
R010406428	40.00	58.00	8.00	R020456421	45.00	62.00	8.00
R010406448	40.00	58.00	10.00	R010456410	45.00	62.00	10.00
R010406441	40.00	60.00	8.00	R020456440	45.00	62.00	10.00
R010406406	40.00	60.00	10.00	R010456432	45.00	62.00	12.00
R020406419	40.00	60.00	10.00	R010456454	45.00	65.00	7.00
R010406401	40.00	62.00	7.00	R010456405	45.00	65.00	8.00
R020406407	40.00	62.00	7.00	R020456407	45.00	65.00	8.00
R010406435	40.00	62.00	8.00	R010456406	45.00	65.00	10.00
R020406420	40.00	62.00	8.00	R020456416	45.00	65.00	10.00
R010406405	40.00	62.00	10.00	R010456436	45.00	68.00	12.00
R020406421	40.00	62.00	10.00	R010456408	45.00	70.00	10.00
R010406466	40.00	65.00	8.00	R010456440	45.00	72.00	8.00
R010406407	40.00	65.00	10.00	R020456433	45.00	72.00	8.00
R010406452	40.00	68.00	8.00	R010456427	45.00	72.00	10.00
R010406453	40.00	68.00	10.00	R010456426	45.00	75.00	8.00
R010406426	40.00	72.00	7.00	R020456434	45.00	75.00	8.00
R010406463	40.00	72.00	10.00	R010456420	45.00	75.00	10.00



**R01**

The **R01** type rotary shaft seal has a metal inserts (Bonded) encased in rubber.



**R02**

The **R02** type rotary shaft seal is similar to R01 type but with an additional dust lip.

Max Spare Part No.	Shaft Dia.	Hsg. Dia.	Seal Ht.	Max Spare Part No.	Shaft Dia.	Hsg. Dia.	Seal Ht.
R020456424	45.00	75.00	10.00	R010506406	50.00	90.00	10.00
R020456423	45.00	80.00	10.00	R010526402	52.00	68.00	8.00
R010456450	45.00	80.00	12.00	R020526412	52.00	68.00	10.00
R020456437	45.00	85.00	10.00	R010526403	52.00	72.00	8.00
R010486401	48.00	62.00	8.00	R010526412	52.00	72.00	10.00
R020486406	48.00	62.00	8.00	R020526409	52.00	72.00	10.00
R010486418	48.00	62.00	10.00	R010526411	52.00	72.00	12.00
R010486410	48.00	65.00	8.00	R010546406	54.00	72.00	10.00
R010486415	48.00	65.00	10.00	R010556416	55.00	70.00	8.00
R020486405	48.00	72.00	8.00	R020556420	55.00	70.00	8.00
R010486422	48.00	72.00	10.00	R010556433	55.00	70.00	10.00
R010506421	50.00	62.00	7.00	R020556444	55.00	72.00	7.00
R020506433	50.00	62.00	7.00	R010556411	55.00	72.00	8.00
R010506432	50.00	62.00	8.00	R020556416	55.00	72.00	8.00
R010506446	50.00	62.00	10.00	R010556403	55.00	72.00	10.00
R010506401	50.00	65.00	8.00	R020556455	55.00	72.00	10.00
R020506419	50.00	65.00	8.00	R010556449	55.00	75.00	8.00
R010506420	50.00	65.00	10.00	R010556435	55.00	75.00	9.00
R020506405	50.00	65.00	10.00	R010556401	55.00	75.00	10.00
R010506407	50.00	68.00	8.00	R020556402	55.00	75.00	10.00
R020506432	50.00	68.00	8.00	R010556431	55.00	75.00	12.00
R010506445	50.00	68.00	10.00	R020556446	55.00	78.00	12.00
R010506435	50.00	70.00	8.00	R010556405	55.00	80.00	8.00
R010506402	50.00	70.00	10.00	R020556415	55.00	80.00	8.00
R020506421	50.00	70.00	10.00	R010556410	55.00	80.00	10.00
R010506436	50.00	70.00	12.00	R020556401	55.00	80.00	10.00
R010506442	50.00	72.00	7.00	R010556425	55.00	80.00	12.00
R010506417	50.00	72.00	8.00	R010556439	55.00	85.00	10.00
R020506411	50.00	72.00	8.00	R020556422	55.00	85.00	10.00
R010506416	50.00	72.00	10.00	R010556428	55.00	90.00	8.00
R020506410	50.00	72.00	10.00	R020556435	55.00	90.00	10.00
R010506444	50.00	72.00	12.00	R010556417	55.00	90.00	10.00
R010506423	50.00	80.00	8.00	R010556465	55.00	100.00	10.00
R020506424	50.00	80.00	8.00	R020556414	55.00	100.00	10.00
R010506426	50.00	80.00	10.00	R010576406	57.15	76.20	9.52
R020506425	50.00	80.00	10.00	R020576402	57.15	76.20	9.52
R010506472	50.00	85.00	10.00	R010586401	58.00	72.00	8.00



**R01**

The **R01** type rotary shaft seal has a metal inserts (Bonded) encased in rubber.



**R02**

The **R02** type rotary shaft seal is similar to R01 type but with an additional dust lip.

Max Spare Part No.	Shaft Dia.	Hsg. Dia.	Seal Ht.	Max Spare Part No.	Shaft Dia.	Hsg. Dia.	Seal Ht.
R020586402	58.00	72.00	8.00	R020656440	65.00	90.00	10.00
R010586411	58.00	80.00	8.00	R010656404	65.00	90.00	13.00
R020586406	58.00	80.00	8.00	R010656423	65.00	95.00	10.00
R010586405	58.00	80.00	10.00	R020656437	65.00	95.00	10.00
R020586403	58.00	80.00	10.00	R010656427	65.00	100.00	10.00
R020606430	60.00	70.00	10.00	R020656416	65.00	100.00	10.00
R010606401	60.00	75.00	8.00	R010666408	66.67	85.72	9.52
R020606401	60.00	75.00	8.00	R010686408	68.00	85.00	10.00
R010606429	60.00	75.00	10.00	R010686407	68.00	90.00	10.00
R010606465	60.00	80.00	7.00	R020686401	68.00	90.00	10.00
R020606407	60.00	80.00	7.00	R010706409	70.00	85.00	8.00
R010606405	60.00	80.00	8.00	R010706418	70.00	90.00	7.00
R020606406	60.00	80.00	8.00	R020706419	70.00	90.00	7.00
R010606404	60.00	80.00	10.00	R010706404	70.00	90.00	10.00
R020606402	60.00	80.00	10.00	R020706407	70.00	90.00	10.00
R010606422	60.00	80.00	12.00	R010706410	70.00	90.00	12.00
R010606420	60.00	85.00	8.00	R010706421	70.00	90.00	13.00
R010606407	60.00	85.00	10.00	R010706412	70.00	95.00	10.00
R020606419	60.00	85.00	10.00	R010706411	70.00	100.00	10.00
R010606412	60.00	85.00	12.00	R020706406	70.00	100.00	10.00
R020606416	60.00	85.00	12.00	R010706425	70.00	100.00	12.00
R010606409	60.00	90.00	8.00	R010706458	70.00	110.00	12.00
R010606406	60.00	90.00	10.00	R010726403	72.00	90.00	10.00
R020606424	60.00	90.00	12.00	R020726408	72.00	90.00	10.00
R010606425	60.00	95.00	10.00	R010756422	75.00	90.00	10.00
R010626401	62.00	85.00	10.00	R010756402	75.00	95.00	10.00
R010636418	63.00	85.00	10.00	R020756401	75.00	95.00	10.00
R010636402	63.50	82.55	9.52	R010756404	75.00	95.00	12.00
R010656408	65.00	80.00	8.00	R010756414	75.00	95.00	13.00
R020656417	65.00	80.00	8.00	R010756408	75.00	100.00	10.00
R010656446	65.00	80.00	10.00	R020756404	75.00	100.00	10.00
R010656421	65.00	85.00	8.00	R010756403	75.00	100.00	12.00
R020656419	65.00	85.00	8.00	R020756410	75.00	100.00	12.00
R010656402	65.00	85.00	10.00	R010756401	75.00	100.00	13.00
R020656401	65.00	85.00	10.00	R020756403	75.00	100.00	13.00
R010656463	65.00	85.00	13.00	R010786401	78.00	100.00	10.00
R010656401	65.00	90.00	10.00	R010806421	80.00	100.00	7.00

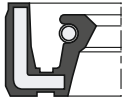

**R01**

The **R01** type rotary shaft seal has a metal inserts (Bonded) encased in rubber.



**R02**

The **R02** type rotary shaft seal is similar to R01 type but with an additional dust lip.

Max Spare Part No.	Shaft Dia.	Hsg. Dia.	Seal Ht.	Max Spare Part No.	Shaft Dia.	Hsg. Dia.	Seal Ht.
R010806401	80.00	100.00	10.00	R020956405	95.00	125.00	12.00
R020806416	80.00	100.00	10.00	R010956404	95.00	125.00	13.00
R010806410	80.00	100.00	12.00	R010956421	95.00	130.00	12.00
R020806402	80.00	100.00	12.00	R010956418	95.00	130.00	13.00
R010806405	80.00	100.00	13.00	R020956428	95.00	170.00	13.00
R020806401	80.00	100.00	13.00	R011006421	100.00	120.00	10.00
R010806409	80.00	105.00	12.00	R021006406	100.00	120.00	10.00
R010806417	80.00	105.00	13.00	R011006401	100.00	120.00	12.00
R010806402	80.00	110.00	10.00	R021006401	100.00	120.00	12.00
R020806407	80.00	110.00	10.00	R011006403	100.00	120.00	13.00
R010806430	80.00	110.00	12.00	R011006424	100.00	125.00	10.00
R020806405	80.00	110.00	12.00	R011006405	100.00	125.00	12.00
R020826405	82.55	114.30	12.70	R021006405	100.00	125.00	12.00
R010856414	85.00	105.00	10.00	R011006407	100.00	130.00	12.00
R010856420	85.00	110.00	10.00	R021006413	100.00	130.00	12.00
R020856434	85.00	110.00	10.00	R011006417	100.00	130.00	13.00
R010856402	85.00	110.00	12.00	R021006409	100.00	130.00	13.00
R020856402	85.00	110.00	12.00	R011056440	105.00	125.00	12.00
R010856405	85.00	120.00	12.00	R011056404	105.00	130.00	12.00
R010856422	85.00	130.00	10.00	R021056401	105.00	130.00	12.00
R020856414	85.00	150.00	12.00	R011056402	105.00	130.00	13.00
R010906404	90.00	110.00	10.00	R021056403	105.00	130.00	13.00
R020906412	90.00	110.00	10.00	R011056406	105.00	140.00	12.00
R010906401	90.00	110.00	12.00	R011056428	105.00	160.00	12.00
R020906401	90.00	110.00	12.00	R011106407	110.00	130.00	10.00
R010906402	90.00	110.00	13.00	R011106406	110.00	130.00	12.00
R010906409	90.00	115.00	13.00	R021106405	110.00	130.00	12.00
R010906406	90.00	120.00	12.00	R011106402	110.00	130.00	13.00
R020906409	90.00	120.00	12.00	R011106405	110.00	140.00	12.00
R010906403	90.00	120.00	13.00	R021106410	110.00	140.00	12.00
R020906402	90.00	120.00	13.00	R011106401	110.00	140.00	13.00
R010956417	95.00	120.00	10.00	R021106404	110.00	140.00	13.00
R010956405	95.00	120.00	12.00	R011106415	110.00	140.00	14.00
R020956423	95.00	120.00	12.00	R021106403	110.00	140.00	14.00
R010956410	95.00	120.00	13.00	R011106408	110.00	150.00	13.00
R020956418	95.00	120.00	13.00	R011156401	115.00	140.00	12.00
R010956408	95.00	125.00	12.00	R021156406	115.00	140.00	12.00



**R01**

The **R01** type rotary shaft seal has a metal inserts (Bonded) encased in rubber.



**R02**

The **R02** type rotary shaft seal is similar to R01 type but with an additional dust lip.

Max Spare Part No.	Shaft Dia.	Hsg. Dia.	Seal Ht.	Max Spare Part No.	Shaft Dia.	Hsg. Dia.	Seal Ht.
R011156411	115.00	140.00	13.00	R021506401	150.00	180.00	13.00
R021156404	115.00	140.00	13.00	R011506406	150.00	180.00	14.00
R011156402	115.00	150.00	12.00	R011506401	150.00	180.00	15.00
R011206414	120.00	140.00	12.00	R021506404	150.00	180.00	15.00
R021206422	120.00	140.00	12.00	R011606407	160.00	185.00	10.00
R011206402	120.00	150.00	12.00	R011606402	160.00	190.00	15.00
R021206406	120.00	150.00	12.00	R021606401	160.00	190.00	15.00
R021206403	120.00	150.00	13.00	R021606406	160.00	240.00	14.00
R011206401	120.00	150.00	13.00	R021606414	160.00	290.00	18.00
R011206407	120.00	150.00	15.00	R011656408	165.00	190.00	15.00
R021206420	120.00	150.00	15.00	R011706403	170.00	200.00	12.00
R011206412	120.00	160.00	12.00	R021706408	170.00	200.00	13.00
R011256401	125.00	150.00	12.00	R011706402	170.00	200.00	15.00
R021256409	125.00	150.00	12.00	R021706404	170.00	200.00	15.00
R011256404	125.00	150.00	13.00	R021756403	175.00	210.00	15.00
R011256403	125.00	160.00	12.00	R011756402	175.00	200.00	15.00
R011306411	130.00	150.00	13.00	R021756404	175.00	200.00	15.00
R011306404	130.00	160.00	12.00	R011806422	180.00	200.00	15.00
R021306401	130.00	160.00	12.00	R011806402	180.00	210.00	15.00
R011306401	130.00	160.00	13.00	R021806402	180.00	210.00	15.00
R021306406	130.00	160.00	13.00	R011856403	185.00	210.00	13.00
R011306413	130.00	160.00	15.00	R011906401	190.00	220.00	15.00
R021306402	130.00	160.00	15.00	R012006404	200.00	230.00	15.00
R011356409	135.00	160.00	12.00	R022006407	200.00	230.00	15.00
R021356409	135.00	160.00	12.00	R012106401	210.00	240.00	15.00
R011356407	135.00	160.00	13.00	R022106401	210.00	240.00	15.00
R011356402	135.00	170.00	12.00	R012206401	220.00	250.00	15.00
R021356404	135.00	170.00	12.00	R022206404	220.00	250.00	15.00
R011406407	140.00	170.00	12.00	R012306401	230.00	260.00	15.00
R011406403	140.00	170.00	13.00	R022306401	230.00	260.00	15.00
R011406404	140.00	170.00	15.00	R012406406	240.00	270.00	15.00
R021406401	140.00	170.00	15.00	R022406408	240.00	270.00	15.00
R011456401	145.00	175.00	15.00	R012506401	250.00	280.00	15.00
R011466402	146.00	166.00	10.00	R022506401	250.00	280.00	15.00
R011506420	150.00	170.00	12.00	R012606406	260.00	290.00	15.00
R011506402	150.00	180.00	12.00	R012606401	260.00	300.00	20.00
R011506404	150.00	180.00	13.00	R022606403	260.00	300.00	20.00



**R01**

The **R01** type rotary shaft seal has a metal inserts (Bonded) encased in rubber.



**R02**

The **R02** type rotary shaft seal is similar to R01 type but with an additional dust lip.

Max Spare Part No.	Shaft Dia.	Hsg. Dia.	Seal Ht.	Max Spare Part No.	Shaft Dia.	Hsg. Dia.	Seal Ht.
R012806402	280.00	310.00	15.00	R013406403	340.00	380.00	20.00
R012806409	280.00	320.00	20.00	R013806401	380.00	420.00	20.00
R022806401	280.00	320.00	20.00	R023806401	380.00	420.00	20.00
R013006401	300.00	340.00	20.00	R024206401	420.00	460.00	20.00
R013206401	320.00	360.00	20.00				

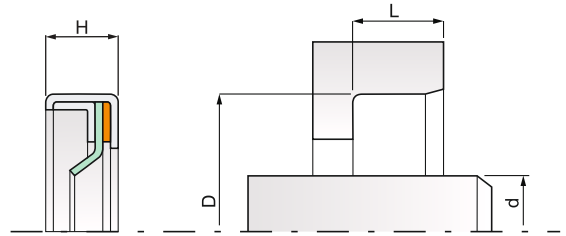

**MATERIAL :**

- A) Sealing Lip : Carbon filled Teflon
- B) Spacer : Rubber
- C) Metal Case : SS 304

**MAX OPERATING CONDITIONS :**

Temp.	-200°C to +260°C	Pressure	10 BAR	Speed	30.0 mtr./sec.
-------	------------------	----------	--------	-------	----------------

Max Spare Part No.	d (mm)	D (mm)	H (mm)	Max Spare Part No.	d (mm)	D (mm)	H (mm)
R560207311	20.00	30.00	7.00	R560557307	55.00	80.00	8.00
R560207315	20.00	32.00	7.00	R560607303	60.00	75.00	8.00
R560257305	25.00	35.00	7.00	R560607301	60.00	80.00	10.00
R560287301	28.00	40.00	7.00	R560627301	62.00	80.00	10.00
R560327302	32.00	55.00	8.00	R560657301	65.00	85.00	10.00
R560357301	35.00	55.00	8.00	R560657313	65.00	90.00	10.00
R560377301	37.00	47.00	5.00	R560707301	70.00	90.00	10.00
R560407308	40.00	55.00	8.00	R560757302	75.00	95.00	10.00
R560407301	40.00	55.00	10.00	R560807302	80.00	100.00	10.00
R560407312	40.00	62.00	8.00	R560907302	90.00	110.00	10.00
R560427301	42.00	55.00	8.00	R560907303	90.00	110.00	12.00
R560457303	45.00	65.00	10.00	R560997302	99.00	130.00	12.00
R560487306	48.00	65.00	8.00	R561007302	100.00	130.00	12.00
R560507315	50.00	62.00	8.00	R561107305	110.00	130.00	12.00
R560507314	50.00	65.00	10.00	R561107303	110.00	140.00	12.00
R560507316	50.00	68.00	8.00	R561207302	120.00	150.00	12.00
R560507313	50.00	70.00	10.00	R561507303	150.00	180.00	12.00
R560557302	55.00	72.00	8.00	R561507302	150.00	180.00	15.00
R560557309	55.00	72.00	10.00				

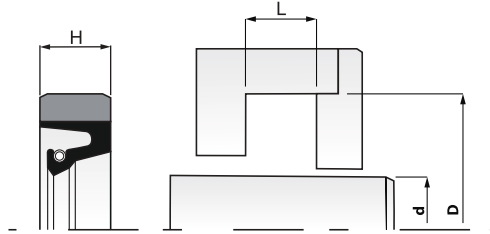

**MATERIAL :** Fabric reinforced NBR

**MAX OPERATING CONDITIONS :**

Temp.	-30°C to +100°C	Pressure	0.5 BAR	Speed	10.0 mtr./sec.
-------	-----------------	----------	---------	-------	----------------

Max Spare Part No.	d (mm)	D (mm)	H (mm)	Max Spare Part No.	d (mm)	D (mm)	H (mm)
R310908405	90.00	110.00	12.00	R312008402	200.00	230.00	15.00
R310958401	95.00	127.00	12.50	R312208401	220.00	260.00	16.00
R311208402	120.00	160.00	16.00	R312208402	220.00	250.00	15.00
R311408403	140.00	170.00	15.00	R312408401	240.00	270.00	15.00
R311508401	150.00	180.00	15.00	R312408402	240.00	280.00	16.00
R311608401	160.00	190.00	15.00	R312608401	260.00	290.00	16.00
R311708404	170.00	200.00	15.00	R312608407	260.00	300.00	20.00
R311808401	180.00	220.00	16.00	R313308401	330.00	374.00	20.00
R311908401	190.00	220.00	15.00	R313408402	340.00	380.00	20.00

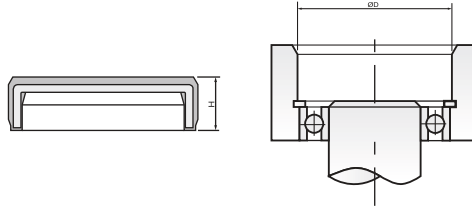

**MATERIAL:** NBR 70 / 75 Shore 'A'

**MAX OPERATING CONDITIONS :**

Temp.	-30°C to +100°C	Pressure	0.5 BAR	Speed	10 m/s
-------	-----------------	----------	---------	-------	--------

Ordering Information (Dimensions in mm)

Max Spare Part No.	D	H	Max Spare Part No.	D	H	Max Spare Part No.	D	H
RB70250805	25.00	7.00	RB70520805	52.00	8.00	RB70850806	85.00	10.00
RB70300802	30.00	7.00	RB70520809	52.00	10.00	RB70900803	90.00	8.00
RB70320802	32.00	7.00	RB70550802	55.00	10.00	RB70900802	90.00	10.00
RB70350807	35.00	5.00	RB70620802	62.00	7.00	RB70900804	90.00	12.00
RB70350803	35.00	7.00	RB70620804	62.00	8.00	RB71000802	100.00	10.00
RB70350802	35.00	8.00	RB70620803	62.00	10.00	RB71000804	100.00	12.00
RB70370803	37.00	7.00	RB70650801	65.00	8.00	RB71100802	110.00	10.00
RB70400803	40.00	7.00	RB70680803	68.00	8.00	RB71100804	110.00	12.00
RB70400804	40.00	8.00	RB70720809	72.00	7.00	RB71200801	120.00	12.00
RB70420802	42.00	7.00	RB70720808	72.00	8.00	RB71250801	125.00	12.00
RB70420805	42.00	8.00	RB70720807	72.00	9.00	RB71300802	130.00	12.00
RB70470805	47.00	6.50	RB70720803	72.00	10.00	RB71400803	140.00	12.00
RB70470803	47.00	7.00	RB70720805	72.00	12.00	RB71400801	140.00	15.00
RB70470807	47.00	10.00	RB70800805	80.00	8.00	RB71500802	150.00	15.00
RB70520806	52.00	6.50	RB70800802	80.00	10.00	RB71600801	160.00	15.00
RB70520803	52.00	7.00	RB70800806	80.00	12.00	RB71800803	180.00	12.00

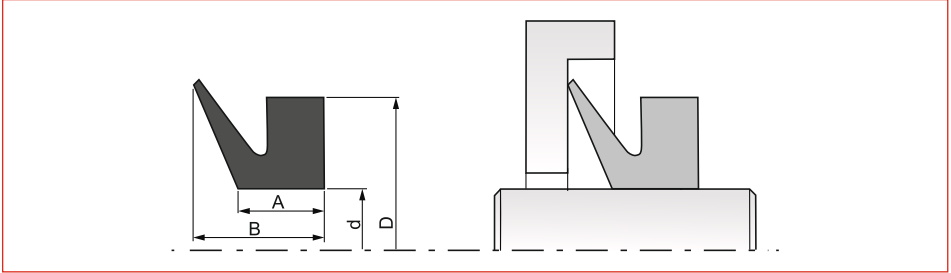

**MATERIAL :** NBR 65<sup>°</sup> / 70<sup>°</sup> Shore 'A'

**MAX OPERATING CONDITIONS :**

Temp.	-30C to +100C	Speed	10.0 mtr./sec.
-------	---------------	-------	----------------

Max Spare Part No.	V Ring Type	d (mm)	D (mm)	Width A / B	Max Spare Part No.	V Ring Type	d (mm)	D (mm)	Width A / B
V010120701	V-14 A	12.50	18.50	3.4/5.5	V011170701	V-130 A	117.00	131.00	7.9/12.8
V010140701	V-16 A	14.00	20.00	3.4/5.5	V011260701	V-140 A	126.00	140.00	7.9/12.8
V010180701	V-20 A	18.00	26.00	4.7/7.5	V011350701	V-150 A	135.00	149.00	7.9/12.8
V010200701	V-22 A	20.00	28.00	4.7/7.5	V011440701	V-160 A	144.00	160.00	9.0/14.5
V010220701	V-25 A	22.00	30.00	4.7/7.5	V011530701	V-170 A	153.00	169.00	9.0/14.5
V010270701	V-30 A	27.00	35.00	4.7/7.5	V011620701	V-180 A	162.00	178.00	9.0/14.5
V010290701	V-32 A	29.00	37.00	4.7/7.5	V011710701	V-190 A	171.00	187.00	9.0/14.5
V010310701	V-35 A	31.00	39.00	4.7/7.5	V011800701	V-199 A	180.00	196.00	9.0/14.5
V010340701	V-38 A	34.00	42.00	4.7 / 7.5	V011800702	V-200 A	180.00	210.00	14.3/25
V010360701	V-40 A	36.00	46.00	5.5/9.0	V011980701	V-220 A	198.00	228.00	14.3/25
V010400701	V-45 A	40.00	50.00	5.5/9.0	V012250701	V-250 A	225.00	255.00	14.3/25
V010450701	V-50 A	45.00	55.00	5.5/9.0	V012330801	-	233.60	246.00	7/11.00
V010490701	V-55 A	49.00	59.00	5.5/9.0	V012470701	V-275 A	247.00	277.00	14.3/25
V010540701	V-60 A	54.00	64.00	5.5/9.0	V012500701	-	250.00	280.00	14.00/25
V010580701	V-65 A	58.00	68.00	5.5/9.0	V012700701	V-300 A	270.00	300.00	14.3/25
V010630701	V-70 A	63.00	75.00	6.8/11.0	V012920701	V-325 A	292.00	322.00	14.3/25
V010670701	V-75 A	67.00	79.00	6.8/11.0	V013000704	-	300.00	330.00	14.30/25
V010720701	V-80 A	72.00	84.00	6.8/11.0	V013150701	V-350 A	315.00	345.00	14.3/25
V010760601	V-85 A	76.00	88.00	6.8/11.0	V013370701	V-375 A	337.00	367.00	14.3/25
V010810701	V-90 A	81.00	93.00	6.8/11.0	V013600701	V-400 A	360.00	390.00	14.3/25
V010850701	V-95 A	85.00	97.00	6.8/11.0	V014050701	V-450 A	405.00	435.00	14.3/30
V010900701	V-100 A	90.00	102.00	6.8/11.0	V014500701	V-500 A	450.00	480.00	14.3/25
V010990701	V-110 A	99.00	113.00	7.9/12.8	V014950701	V-550 A	495.00	525.00	14.3/25
V011080701	V-120 A	108.00	122.00	7.9/12.8					

For other technical details refer our Technical Catalogue.

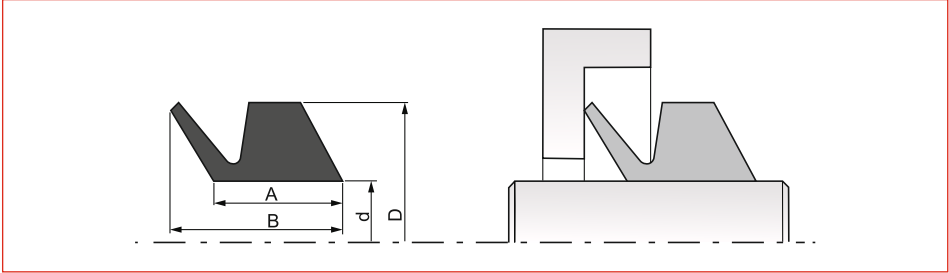

**MATERIAL :** NBR 65 / 70<sup>o</sup> Shore 'A'

**MAX OPERATING CONDITIONS :**

Temp.	-30C to +100C	Speed	10.0 mtr./sec.
-------	---------------	-------	----------------

Max Spare Part No.	V Ring Type	d (mm)	D (mm)	Width A / B	Max Spare Part No.	V Ring Type	d (mm)	D (mm)	Width A / B
V020120701	V-14 S	12.50	18.50	5.60/7.70	V020720701	V-80 S	72.00	84.00	11.30/15.50
V020180701	V-20 S	18.00	26.00	7.9 / 10.5	V020760701	V-85 S	76.00	88.00	11.30/15.50
V020220701	V-25 S	22.00	30.00	7.90/10.50	V020810701	V-90 S	81.00	93.00	11.30/15.50
V020270701	V-30 S	27.00	35.00	7.90/10.50	V020850701	V-95 S	85.00	97.00	11.30/15.50
V020290701	V-32 S	29.00	37.00	7.90/10.50	V020900701	V-100 S	90.00	102.00	11.3 / 15.5
V020310701	V-35 S	31.00	39.00	7.90/10.50	V020990701	V-110 S	99.00	113.00	13.10/18.00
V020360701	V-40 S	36.00	46.00	9.50/13.00	V021080701	V-120 S	108.00	122.00	13.10/18.00
V020400701	V-45 S	40.00	50.00	9.50/13.00	V021170701	V-130 S	117.00	131.00	13.10/18.00
V020450701	V-50 S	45.00	55.00	9.50/13.00	V021260701	V-140 S	126.00	140.00	13.10/18.00
V020490701	V-55 S	49.00	59.00	9.50/13.00	V021350701	V-150 S	135.00	149.00	13.10/18.00
V020540701	V-60 S	54.00	64.00	9.50/13.00	V021440701	V-160 S	144.00	160.00	15.00/20.50
V020580701	V-65 S	58.00	68.00	9.50/13.00	V021530701	V-170 S	153.00	169.00	15.00/20.50
V020630701	V-70 S	63.00	75.00	11.30/15.50	V021710701	V-190 S	171.00	187.00	15.00/20.50
V020670701	V-75 S	67.00	79.00	11.30/15.50	V021800701	V-199 S	180.00	196.00	15.00/20.50

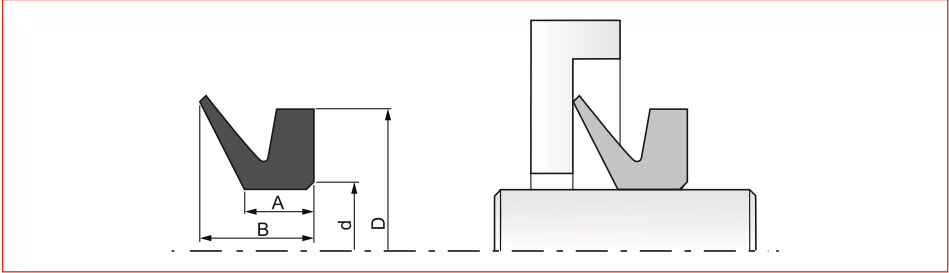

**MATERIAL :** NBR 65 / 70 Shore 'A'

**MAX OPERATING CONDITIONS :**

Temp.	-30C to +100C	Speed	10.0 mtr./sec.
-------	---------------	-------	----------------

Max Spare Part No.	V Ring Type	d (mm)	D (mm)	Width A / B	Max Spare Part No.	V Ring Type	d (mm)	D (mm)	Width A / B
V031170701	V-130 L	117.00	130.00	6.00/10.50	V032470701	V-275 L	247.00	260.00	6.00/10.50
V031260701	V-140 L	126.00	139.00	6.00/10.50	V032700701	V-300 L	270.00	283.00	6.00/10.50
V031350701	V-150 L	135.00	148.00	6.00/10.50	V032920701	V-325 L	292.00	305.00	6.00/10.50
V031440701	V-160 L	144.00	157.00	6.00/10.50	V033150701	V-350 L	315.00	328.00	6.00/10.50
V031710701	V-190 L	171.00	184.00	6.00/10.50	V033370701	V-375 L	337.00	350.00	6.00/10.50
V031820701	V-200 L	182.00	195.00	6.00/10.50	V033600701	V-400 L	360.00	373.00	6.00/10.50
V031980701	V-220 L	198.00	211.00	6.00/10.50	V034050701	V-450 L	405.00	418.00	6.00/10.50
V032250701	V-250 L	225.00	238.00	6.00/10.50	V035400701	V-600 L	540.00	553.00	6.00/10.50

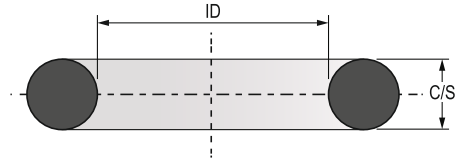
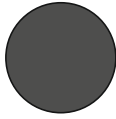

**MATERIAL:** NBR 70° / 75° Shore 'A'

**MAX OPERATING CONDITIONS :**

Temp. -30°C to +100°C      Pressure 100 BAR

Ordering Information (Dimensions in mm)

IS : 9975 - Dimension Tolerance

Max Spare Part No.	ID (mm)	C/S (mm)	Max Spare Part No.	ID (mm)	C/S (mm)	Max Spare Part No.	ID (mm)	C/S (mm)
OR15200142-08	1.42	1.52	OR30000400-08	4.00	3.00	OR19000580-10	5.80	1.90
OR20000200-08	2.00	2.00	OR25000400-08	4.00	2.50	OR18000580-10	5.80	1.80
OR10000200-08	2.00	1.00	OR15000400-08	4.00	1.50	OR35300594-08	5.94	3.53
OR15000200-08	2.00	1.50	OR35300434-08	4.34	3.53	OR20000600-08	6.00	2.00
OR26200206-08	2.06	2.62	OR26200442-08	4.42	2.62	OR25000600-08	6.00	2.50
OR17000240-08	2.40	1.70	OR17800447-08	4.47	1.78	OR15000600-08	6.00	1.50
OR20000250-08	2.50	2.00	OR15000450-08	4.50	1.50	OR30000600-08	6.00	3.00
OR15000250-08	2.50	1.50	OR20000450-08	4.50	2.00	OR22000600-08	6.00	2.20
OR17800257-08	2.57	1.78	OR17000470-08	4.70	1.70	OR40000600-08	6.00	4.00
OR16000280-08	2.80	1.60	OR19000480-10	4.80	1.90	OR20000600-11	6.00	2.00
OR26200284-08	2.84	2.62	OR19000480-08	4.80	1.90	OR12500600-08	6.00	1.25
OR17800290-08	2.90	1.78	OR19000490-10	4.90	1.90	OR10000600-08	6.00	1.00
OR10000300-08	3.00	1.00	OR20000500-08	5.00	2.00	OR26200602-08	6.02	2.62
OR15000300-08	3.00	1.50	OR25000500-08	5.00	2.50	OR17800607-10	6.07	1.78
OR30000300-08	3.00	3.00	OR10000500-08	5.00	1.00	OR17800607-08	6.07	1.78
OR12500300-08	3.00	1.25	OR17800500-08	5.00	1.78	OR24000630-08	6.30	2.40
OR20000300-08	3.00	2.00	OR25000500-10	5.00	2.50	OR18000630-08	6.30	1.80
OR25000300-08	3.00	2.50	OR30000500-08	5.00	3.00	OR15000650-08	6.50	1.50
OR15000330-08	3.30	1.50	OR35000500-08	5.00	3.50	OR20000650-08	6.50	2.00
OR20000350-08	3.50	2.00	OR15000500-08	5.00	1.50	OR20000650-10	6.50	2.00
OR15000350-08	3.50	1.50	OR26200523-08	5.23	2.62	OR25000650-08	6.50	2.50
OR10000350-08	3.50	1.00	OR17800528-10	5.28	1.78	OR17800675-08	6.75	1.78
OR25000350-08	3.50	2.50	OR17800528-08	5.28	1.78	OR20000680-10	6.80	2.00
OR26200363-08	3.63	2.62	OR24000530-08	5.30	2.40	OR19000680-10	6.80	1.90
OR17800368-08	3.68	1.78	OR22500530-08	5.30	2.25	OR10000700-08	7.00	1.00
OR10000400-08	4.00	1.00	OR24000530-10	5.30	2.40	OR15000700-08	7.00	1.50
OR18000400-08	4.00	1.80	OR20000550-08	5.50	2.00	OR20000700-08	7.00	2.00
OR20000400-08	4.00	2.00	OR19000550-10	5.50	1.90	OR25000700-08	7.00	2.50
OR50000400-08	4.00	5.00	OR15000550-08	5.50	1.50	OR35000700-08	7.00	3.50
OR12000400-08	4.00	1.20	OR12000560-08	5.60	1.20	OR40000700-08	7.00	4.00
OR17000400-08	4.00	1.70	OR24000560-08	5.60	2.40	OR17800700-08	7.00	1.78

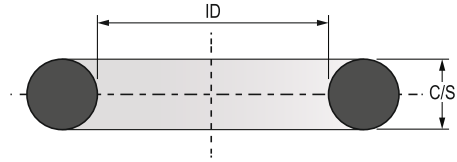
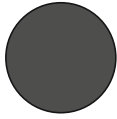

Max Spare Part No.	ID (mm)	C/S (mm)	Max Spare Part No.	ID (mm)	C/S (mm)	Max Spare Part No.	ID (mm)	C/S (mm)
OR17800700-08	7.00	1.78	OR24000830-10	8.30	2.40	OR25000950-08	9.50	2.50
OR30000700-08	7.00	3.00	OR18000840-08	8.40	1.80	OR24000960-10	9.60	2.40
OR16000710-08	7.10	1.60	OR27000850-08	8.50	2.70	OR17800975-08	9.75	1.78
OR32000720-08	7.20	3.20	OR25000850-08	8.50	2.50	OR17800975-10	9.75	1.78
OR20000720-08	7.20	2.00	OR15000850-08	8.50	1.50	OR20000980-10	9.80	2.00
OR19000720-08	7.20	1.90	OR15000850-10	8.50	1.50	OR24000980-10	9.80	2.40
OR24000730-10	7.30	2.40	OR20000850-08	8.50	2.00	OR24000980-10	9.80	2.40
OR23000740-08	7.40	2.30	OR32000850-08	8.50	3.20	OR19000980-10	9.80	1.90
OR23000740-10	7.40	2.30	OR17800873-08	8.73	1.78	OR24000980-08	9.80	2.40
OR15000750-08	7.50	1.50	OR19000880-10	8.80	1.90	OR26200985-10	9.85	2.62
OR17500750-08	7.50	1.75	OR19000880-08	8.80	1.90	OR26200985-10	9.85	2.62
OR20000750-11	7.50	2.00	OR20000900-10	9.00	2.00	OR15001000-08	10.00	1.50
OR20000750-08	7.50	2.00	OR25000900-08	9.00	2.50	OR20001000-08	10.00	2.00
OR35300752-08	7.52	3.53	OR16000900-08	9.00	1.60	OR25001000-08	10.00	2.50
OR26200759-08	7.59	2.62	OR35000900-08	9.00	3.50	OR22001000-08	10.00	2.20
OR24000760-08	7.60	2.40	OR10000900-08	9.00	1.00	OR20001000-10	10.00	2.00
OR25000760-08	7.60	2.50	OR18000900-10	9.00	1.80	OR26201000-08	10.00	2.62
OR17800765-10	7.65	1.78	OR30000900-08	9.00	3.00	OR30001000-08	10.00	3.00
OR17800765-11	7.65	1.78	OR15000900-11	9.00	1.50	OR40001000-08	10.00	4.00
OR17800765-08	7.65	1.78	OR40000900-08	9.00	4.00	OR35001000-08	10.00	3.50
OR16500766-08	7.66	1.65	OR15000900-08	9.00	1.50	OR10001000-08	10.00	1.00
OR19000780-10	7.80	1.90	OR20000900-08	9.00	2.00	OR18001000-08	10.00	1.80
OR19000780-08	7.80	1.90	OR18000900-08	9.00	1.80	OR15001050-08	10.50	1.50
OR20000800-08	8.00	2.00	OR35300912-08	9.12	3.53	OR27001050-08	10.50	2.70
OR40000800-08	8.00	4.00	OR26200919-10	9.19	2.62	OR23001050-08	10.50	2.30
OR22000800-08	8.00	2.20	OR26200919-08	9.19	2.62	OR18001050-08	10.50	1.80
OR10000800-08	8.00	1.00	OR17800925-08	9.25	1.78	OR25001050-08	10.50	2.50
OR30000800-08	8.00	3.00	OR17800925-10	9.25	1.78	OR30001050-08	10.50	3.00
OR12500800-08	8.00	1.25	OR17800925-11	9.25	1.78	OR20001050-08	10.50	2.00
OR35000800-08	8.00	3.50	OR22000930-08	9.30	2.20	OR25001050-10	10.50	2.50
OR18000800-08	8.00	1.80	OR24000930-08	9.30	2.40	OR24001060-10	10.60	2.40
OR19000800-10	8.00	1.90	OR20000950-10	9.50	2.00	OR35301069-08	10.69	3.53
OR15000800-08	8.00	1.50	OR30000950-08	9.50	3.00	OR25001070-10	10.70	2.50
OR25000800-08	8.00	2.50	OR25000950-10	9.50	2.50	OR26201077-10	10.77	2.62
OR20000800-10	8.00	2.00	OR20000950-08	9.50	2.00	OR26201077-08	10.77	2.62
OR19000800-08	8.00	1.90	OR18000950-08	9.50	1.80	OR24001080-08	10.80	2.40
OR16000810-08	8.10	1.60	OR15000950-08	9.50	1.50	OR24001080-10	10.80	2.40

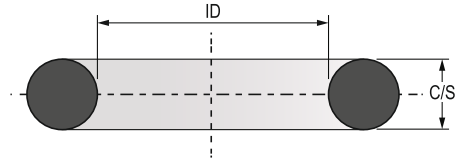
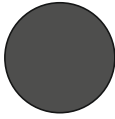

Max Spare Part No.	ID (mm)	C/S (mm)	Max Spare Part No.	ID (mm)	C/S (mm)	Max Spare Part No.	ID (mm)	C/S (mm)
OR17801082-10	10.82	1.78	OR40001200-08	12.00	4.00	OR24001360-10	13.60	2.40
OR17801082-11	10.82	1.78	OR18001200-10	12.00	1.80	OR27001360-10	13.60	2.70
OR17801082-08	10.82	1.78	OR18001200-08	12.00	1.80	OR27001360-08	13.60	2.70
OR10001100-08	11.00	1.00	OR18001220-10	12.20	1.80	OR53301364-08	13.64	5.33
OR20001100-08	11.00	2.00	OR19001220-10	12.20	1.90	OR24001380-10	13.80	2.40
OR25001100-10	11.00	2.50	OR35301229-08	12.29	3.53	OR24001380-08	13.80	2.40
OR40001100-08	11.00	4.00	OR24001230-10	12.30	2.40	OR35301387-08	13.87	3.53
OR24001100-10	11.00	2.40	OR26201237-08	12.37	2.62	OR26201394-10	13.94	2.62
OR30001100-08	11.00	3.00	OR17801242-10	12.42	1.78	OR26201394-08	13.94	2.62
OR35001100-08	11.00	3.50	OR17801242-11	12.42	1.78	OR17801399-10	13.99	1.78
OR18001100-08	11.00	1.80	OR17801242-08	12.42	1.78	OR10001400-08	14.00	1.00
OR15001100-08	11.00	1.50	OR25001250-08	12.50	2.50	OR30001400-08	14.00	3.00
OR25001100-08	11.00	2.50	OR20001250-08	12.50	2.00	OR20001400-10	14.00	2.00
OR23801111-08	11.11	2.38	OR20001250-10	12.50	2.00	OR25001400-10	14.00	2.50
OR22001140-08	11.40	2.20	OR35001250-08	12.50	3.50	OR40001400-08	14.00	4.00
OR20001150-08	11.50	2.00	OR15001250-08	12.50	1.50	OR19001400-10	14.00	1.90
OR17501150-08	11.50	1.75	OR31001270-08	12.70	3.10	OR25001400-08	14.00	2.50
OR25001150-08	11.50	2.50	OR16001270-08	12.70	1.60	OR17001400-08	14.00	1.70
OR43001150-08	11.50	4.30	OR24001280-10	12.80	2.40	OR17801400-10	14.00	1.78
OR15001150-08	11.50	1.50	OR24001281-10	12.81	2.40	OR17801400-08	14.00	1.78
OR25001150-10	11.50	2.50	OR25001300-08	13.00	2.50	OR20001400-08	14.00	2.00
OR30001150-08	11.50	3.00	OR10001300-08	13.00	1.00	OR15001400-08	14.00	1.50
OR23001160-08	11.60	2.30	OR20001300-08	13.00	2.00	OR16001410-08	14.10	1.60
OR25001170-10	11.70	2.50	OR40001300-08	13.00	4.00	OR15101437-10	14.37	1.51
OR24001180-10	11.80	2.40	OR26201300-10	13.00	2.62	OR25001450-08	14.50	2.50
OR24001180-08	11.80	2.40	OR20001300-10	13.00	2.00	OR20001450-08	14.50	2.00
OR19801189-11	11.89	1.98	OR35001300-08	13.00	3.50	OR15001450-08	14.50	1.50
OR26201191-08	11.91	2.62	OR17801300-08	13.00	1.78	OR30001450-08	14.50	3.00
OR15001200-08	12.00	1.50	OR30001300-08	13.00	3.00	OR24001450-10	14.50	2.40
OR20001200-08	12.00	2.00	OR15001300-08	13.00	1.50	OR35001450-08	14.50	3.50
OR25001200-08	12.00	2.50	OR26201310-08	13.10	2.62	OR24001480-10	14.80	2.40
OR10001200-08	12.00	1.00	OR20001350-08	13.50	2.00	OR25001500-08	15.00	2.50
OR35001200-08	12.00	3.50	OR40001350-08	13.50	4.00	OR50001500-08	15.00	5.00
OR20001200-11	12.00	2.00	OR25001350-10	13.50	2.50	OR30001500-10	15.00	3.00
OR30001200-08	12.00	3.00	OR15001350-08	13.50	1.50	OR40001500-08	15.00	4.00
OR22001200-08	12.00	2.20	OR25001350-08	13.50	2.50	OR17801500-08	15.00	1.78
OR20001200-10	12.00	2.00	OR20001350-10	13.50	2.00	OR10001500-08	15.00	1.00

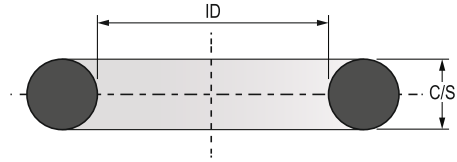
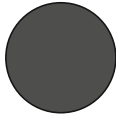

Max Spare Part No.	ID (mm)	C/S (mm)	Max Spare Part No.	ID (mm)	C/S (mm)	Max Spare Part No.	ID (mm)	C/S (mm)
OR15001500-08	15.00	1.50	OR30001650-08	16.50	3.00	OR35001800-08	18.00	3.50
OR25001500-10	15.00	2.50	OR25001650-10	16.50	2.50	OR10001800-08	18.00	1.00
OR35001500-08	15.00	3.50	OR35001650-10	16.50	3.50	OR40001800-08	18.00	4.00
OR20001500-08	15.00	2.00	OR25001650-08	16.50	2.50	OR50001800-08	18.00	5.00
OR30001500-08	15.00	3.00	OR34001670-10	16.70	3.40	OR35001800-10	18.00	3.50
OR26201508-08	15.08	2.62	OR35001680-10	16.80	3.50	OR18001800-08	18.00	1.80
OR24001530-10	15.30	2.40	OR53301682-08	16.82	5.33	OR25001800-10	18.00	2.50
OR24001530-08	15.30	2.40	OR15001700-08	17.00	1.50	OR24001830-08	18.30	2.40
OR35301547-08	15.47	3.53	OR15001700-11	17.00	1.50	OR36001830-10	18.30	3.60
OR20001550-08	15.50	2.00	OR50001700-08	17.00	5.00	OR53301842-08	18.42	5.33
OR25001550-10	15.50	2.50	OR20001700-08	17.00	2.00	OR30001850-08	18.50	3.00
OR15001550-10	15.50	1.50	OR10001700-08	17.00	1.00	OR15001850-08	18.50	1.50
OR30001550-08	15.50	3.00	OR40001700-08	17.00	4.00	OR25001850-08	18.50	2.50
OR26201554-11	15.54	2.62	OR30001700-08	17.00	3.00	OR24001860-10	18.60	2.40
OR26201554-10	15.54	2.62	OR25001700-08	17.00	2.50	OR35301864-10	18.64	3.53
OR26201554-08	15.54	2.62	OR35301704-08	17.04	3.53	OR35301864-11	18.64	3.53
OR17801560-08	15.60	1.78	OR26201710-10	17.10	2.62	OR35301864-08	18.64	3.53
OR17801560-11	15.60	1.78	OR16001710-08	17.10	1.60	OR26201872-08	18.72	2.62
OR23001560-08	15.60	2.30	OR26201712-10	17.12	2.62	OR26201872-10	18.72	2.62
OR24001580-10	15.80	2.40	OR26201712-08	17.12	2.62	OR17801877-08	18.77	1.78
OR10001600-08	16.00	1.00	OR17801717-08	17.17	1.78	OR17801877-11	18.77	1.78
OR40001600-08	16.00	4.00	OR17801717-10	17.17	1.78	OR17801877-10	18.77	1.78
OR30001600-10	16.00	3.00	OR24001730-10	17.30	2.40	OR25001900-08	19.00	2.50
OR35001600-10	16.00	3.50	OR24001730-08	17.30	2.40	OR30001900-08	19.00	3.00
OR50001600-08	16.00	5.00	OR25001750-10	17.50	2.50	OR35001900-08	19.00	3.50
OR15001600-08	16.00	1.50	OR20001750-08	17.50	2.00	OR40001900-08	19.00	4.00
OR17001600-08	16.00	1.70	OR30001750-08	17.50	3.00	OR50001900-08	19.00	5.00
OR30001600-08	16.00	3.00	OR25001750-08	17.50	2.50	OR27501900-08	19.00	2.75
OR25001600-08	16.00	2.50	OR22501755-08	17.55	2.25	OR18001900-10	19.00	1.80
OR35001600-08	16.00	3.50	OR24001780-10	17.80	2.40	OR20001900-08	19.00	2.00
OR20001600-08	16.00	2.00	OR24001780-11	17.80	2.40	OR10001900-10	19.00	1.00
OR16001610-10	16.10	1.60	OR26201796-08	17.96	2.62	OR15001900-08	19.00	1.50
OR24001630-11	16.30	2.40	OR26201796-10	17.96	2.62	OR18001900-08	19.00	1.80
OR24001630-10	16.30	2.40	OR15001800-08	18.00	1.50	OR20001900-10	19.00	2.00
OR24001630-08	16.30	2.40	OR20001800-08	18.00	2.00	OR25001900-10	19.00	2.50
OR22001635-08	16.35	2.20	OR25001800-08	18.00	2.50	OR31701905-08	19.05	3.17
OR20001650-08	16.50	2.00	OR30001800-08	18.00	3.00	OR16001920-10	19.20	1.60

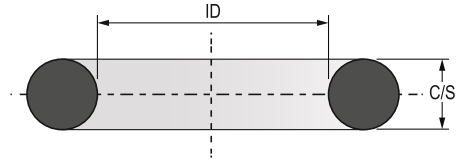
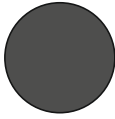

Max Spare Part No.	ID (mm)	C/S (mm)	Max Spare Part No.	ID (mm)	C/S (mm)	Max Spare Part No.	ID (mm)	C/S (mm)
OR25001950-08	19.50	2.50	OR40002100-08	21.00	4.00	OR20002300-10	23.00	2.00
OR30001950-08	19.50	3.00	OR50002100-08	21.00	5.00	OR30002300-10	23.00	3.00
OR25001950-10	19.50	2.50	OR30002100-08	21.00	3.00	OR15002300-08	23.00	1.50
OR35301950-10	19.50	3.53	OR60002100-08	21.00	6.00	OR30002300-08	23.00	3.00
OR24001980-10	19.80	2.40	OR10002100-08	21.00	1.00	OR40002300-08	23.00	4.00
OR53301999-08	19.99	5.33	OR18002100-11	21.00	1.80	OR53302316-08	23.16	5.33
OR15002000-08	20.00	1.50	OR25002100-08	21.00	2.50	OR19002322-10	23.22	1.90
OR20002000-08	20.00	2.00	OR20002140-08	21.40	2.00	OR17802325-10	23.25	1.78
OR25002000-08	20.00	2.50	OR25002150-10	21.50	2.50	OR35302339-08	23.39	3.53
OR35002000-08	20.00	3.50	OR25002150-08	21.50	2.50	OR35302339-10	23.39	3.53
OR35002000-10	20.00	3.50	OR30002150-08	21.50	3.00	OR26202347-10	23.47	2.62
OR50002000-08	20.00	5.00	OR53302160-08	21.60	5.33	OR26202347-08	23.47	2.62
OR10002000-08	20.00	1.00	OR24002180-10	21.80	2.40	OR35002350-08	23.50	3.50
OR18002000-10	20.00	1.80	OR35302182-08	21.82	3.53	OR35002350-10	23.50	3.50
OR20002000-10	20.00	2.00	OR26202189-08	21.89	2.62	OR20002350-10	23.50	2.00
OR25002000-10	20.00	2.50	OR26202189-10	21.89	2.62	OR30002350-10	23.50	3.00
OR22002000-08	20.00	2.20	OR17802195-08	21.95	1.78	OR17802352-08	23.52	1.78
OR30002000-08	20.00	3.00	OR17802195-10	21.95	1.78	OR17802352-10	23.52	1.78
OR40002000-08	20.00	4.00	OR25002200-08	22.00	2.50	OR35002360-10	23.60	3.55
OR35302022-10	20.22	3.53	OR30002200-08	22.00	3.00	OR25002360-08	23.60	2.50
OR35302022-08	20.22	3.53	OR40002200-08	22.00	4.00	OR35002370-10	23.70	3.50
OR26202029-10	20.29	2.62	OR35002200-08	22.00	3.50	OR20002400-08	24.00	2.00
OR26202029-08	20.29	2.62	OR50002200-08	22.00	5.00	OR35002400-08	24.00	3.50
OR24002030-11	20.30	2.40	OR20002200-08	22.00	2.00	OR45002400-08	24.00	4.50
OR24002030-08	20.30	2.40	OR15002200-08	22.00	1.50	OR40002400-08	24.00	4.00
OR17802035-08	20.35	1.78	OR26202223-10	22.23	2.62	OR50002400-08	24.00	5.00
OR34002040-10	20.40	3.40	OR26202223-08	22.23	2.62	OR30002400-10	24.00	3.00
OR35002050-10	20.50	3.50	OR24002230-08	22.30	2.40	OR15002400-08	24.00	1.50
OR20002050-10	20.50	2.00	OR15002250-08	22.50	1.50	OR30002400-08	24.00	3.00
OR24002060-10	20.60	2.40	OR20002250-10	22.50	2.00	OR35002400-10	24.00	3.50
OR35002070-10	20.70	3.50	OR31002250-08	22.50	3.10	OR25002400-08	24.00	2.50
OR34002070-10	20.70	3.40	OR35302270-10	22.70	3.53	OR25002440-08	24.40	2.50
OR24002080-10	20.80	2.40	OR20002300-08	23.00	2.00	OR31002440-10	24.40	3.10
OR25002080-10	20.80	2.50	OR35002300-08	23.00	3.50	OR35002450-08	24.50	3.50
OR20002100-08	21.00	2.00	OR10002300-08	23.00	1.00	OR35002450-10	24.50	3.50
OR35002100-08	21.00	3.50	OR25002300-08	23.00	2.50	OR40002450-08	24.50	4.00
OR15002100-08	21.00	1.50	OR50002300-08	23.00	5.00	OR30002450-08	24.50	3.00

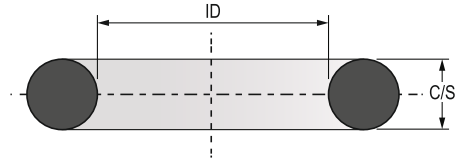
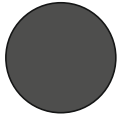

Max Spare Part No.	ID (mm)	C/S (mm)	Max Spare Part No.	ID (mm)	C/S (mm)	Max Spare Part No.	ID (mm)	C/S (mm)
OR36002460-10	24.60	3.60	OR30002600-10	26.00	3.00	OR35302817-08	28.17	3.53
OR35302470-10	24.70	3.53	OR40002600-08	26.00	4.00	OR35302817-10	28.17	3.53
OR17802470-10	24.70	1.78	OR20002600-10	26.00	2.00	OR26202824-08	28.24	2.62
OR53302477-08	24.77	5.33	OR60002600-08	26.00	6.00	OR26202824-10	28.24	2.62
OR35302499-08	24.99	3.53	OR35002600-08	26.00	3.50	OR17802830-08	28.30	1.78
OR35302499-10	24.99	3.53	OR20002600-08	26.00	2.00	OR35302840-10	28.40	3.53
OR35302499-11	24.99	3.53	OR53302634-08	26.34	5.33	OR36002850-10	28.50	3.60
OR25002500-08	25.00	2.50	OR30002650-10	26.50	3.00	OR35002870-10	28.70	3.50
OR26202500-10	25.00	2.62	OR36002650-10	26.50	3.60	OR30002900-08	29.00	3.00
OR30002500-08	25.00	3.00	OR30002650-08	26.50	3.00	OR50002900-08	29.00	5.00
OR35302500-10	25.00	3.53	OR35302657-10	26.57	3.53	OR30002900-10	29.00	3.00
OR55002500-08	25.00	5.50	OR35302657-08	26.57	3.53	OR40002900-08	29.00	4.00
OR10002500-08	25.00	1.00	OR26202664-10	26.64	2.62	OR35002900-08	29.00	3.50
OR17502500-08	25.00	1.75	OR26202664-08	26.64	2.62	OR15002900-08	29.00	1.50
OR40002500-08	25.00	4.00	OR17802670-08	26.70	1.78	OR20002900-08	29.00	2.00
OR60002500-08	25.00	6.00	OR30002700-08	27.00	3.00	OR25002900-08	29.00	2.50
OR15002500-08	25.00	1.50	OR35002700-08	27.00	3.50	OR35302917-10	29.17	3.53
OR32002500-08	25.00	3.20	OR40002700-08	27.00	4.00	OR35002920-10	29.20	3.50
OR50002500-08	25.00	5.00	OR50002700-08	27.00	5.00	OR32002920-10	29.20	3.20
OR20002500-08	25.00	2.00	OR35002700-10	27.00	3.50	OR31002940-10	29.40	3.10
OR26202507-10	25.07	2.62	OR20002700-08	27.00	2.00	OR25002940-08	29.40	2.50
OR26202507-08	25.07	2.62	OR15002700-08	27.00	1.50	OR30002950-08	29.50	3.00
OR17802512-08	25.12	1.78	OR25002700-08	27.00	2.50	OR53302951-08	29.51	5.33
OR17802512-10	25.12	1.78	OR35302740-10	27.40	3.53	OR29402974-11	29.74	2.94
OR24002530-11	25.30	2.40	OR35002750-10	27.50	3.50	OR35302974-08	29.74	3.53
OR24002530-08	25.30	2.40	OR30002750-08	27.50	3.00	OR29402974-08	29.74	2.94
OR35002540-10	25.40	3.50	OR24002760-10	27.60	2.40	OR35302974-10	29.74	3.53
OR30002550-08	25.50	3.00	OR35002770-10	27.70	3.50	OR26202982-10	29.82	2.62
OR35002570-10	25.70	3.50	OR36002780-10	27.80	3.60	OR26202982-08	29.82	2.62
OR35302580-10	25.80	3.53	OR53302794-08	27.94	5.33	OR17802987-10	29.87	1.78
OR35302580-08	25.80	3.53	OR25002800-08	28.00	2.50	OR17802987-08	29.87	1.78
OR25002600-08	26.00	2.50	OR35002800-08	28.00	3.50	OR10003000-08	30.00	1.00
OR30002600-08	26.00	3.00	OR15002800-08	28.00	1.50	OR25003000-08	30.00	2.50
OR50002600-08	26.00	5.00	OR20002800-08	28.00	2.00	OR35003000-08	30.00	3.50
OR15002600-08	26.00	1.50	OR30002800-08	28.00	3.00	OR40003000-08	30.00	4.00
OR45002600-08	26.00	4.50	OR40002800-08	28.00	4.00	OR45003000-08	30.00	4.50
OR10002600-08	26.00	1.00	OR50002800-08	28.00	5.00	OR20003000-08	30.00	2.00

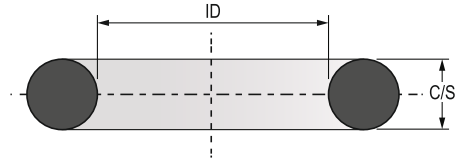
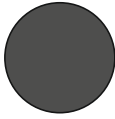

Max Spare Part No.	ID (mm)	C/S (mm)	Max Spare Part No.	ID (mm)	C/S (mm)	Max Spare Part No.	ID (mm)	C/S (mm)
OR28003000-08	30.00	2.80	OR15003200-08	32.00	1.50	OR26203459-10	34.59	2.62
OR60003000-08	30.00	6.00	OR30003250-08	32.50	3.00	OR26203459-08	34.59	2.62
OR20003000-10	30.00	2.00	OR35003250-10	32.50	3.50	OR17803465-10	34.65	1.78
OR15003000-08	30.00	1.50	OR35003250-08	32.50	3.50	OR17803465-08	34.65	1.78
OR30003000-08	30.00	3.00	OR53303269-08	32.69	5.33	OR35003470-10	34.70	3.50
OR50003000-08	30.00	5.00	OR35303292-10	32.92	3.53	OR25003500-08	35.00	2.50
OR40003050-08	30.50	4.00	OR35303292-11	32.92	3.53	OR30003500-08	35.00	3.00
OR35303053-10	30.53	3.53	OR35303292-08	32.92	3.53	OR35003500-08	35.00	3.50
OR35003100-08	31.00	3.50	OR26203299-08	32.99	2.62	OR20003500-08	35.00	2.00
OR20003100-08	31.00	2.00	OR26203299-10	32.99	2.62	OR15003500-08	35.00	1.50
OR15003100-08	31.00	1.50	OR20003300-08	33.00	2.00	OR10003500-08	35.00	1.00
OR40003100-08	31.00	4.00	OR40003300-08	33.00	4.00	OR50003500-08	35.00	5.00
OR50003100-08	31.00	5.00	OR30003300-08	33.00	3.00	OR40003500-08	35.00	4.00
OR25003100-10	31.00	2.50	OR35003300-08	33.00	3.50	OR30003550-08	35.50	3.00
OR17803100-10	31.00	1.78	OR15003300-08	33.00	1.50	OR26203576-08	35.76	2.62
OR30003100-08	31.00	3.00	OR50003300-08	33.00	5.00	OR40003600-08	36.00	4.00
OR25003100-08	31.00	2.50	OR25003300-08	33.00	2.50	OR25003600-08	36.00	2.50
OR53303112-08	31.12	5.33	OR17803305-08	33.05	1.78	OR50003600-08	36.00	5.00
OR30003120-08C	31.20	3.00	OR24003330-08	33.30	2.40	OR30003600-08	36.00	3.00
OR35303134-08	31.34	3.53	OR24003330-11	33.30	2.40	OR18003600-08	36.00	1.80
OR35303134-10	31.34	3.53	OR35303340-10	33.40	3.53	OR20003600-08	36.00	2.00
OR26203142-08	31.42	2.62	OR35003370-10	33.70	3.50	OR15003600-08	36.00	1.50
OR26203142-10	31.42	2.62	OR20003400-08	34.00	2.00	OR35303609-08	36.09	3.53
OR17803147-08	31.47	1.78	OR35003400-10	34.00	3.50	OR35303609-10	36.09	3.53
OR18503150-10	31.50	1.85	OR15003400-08	34.00	1.50	OR26203617-10	36.17	2.62
OR25003150-08	31.50	2.50	OR30003400-08	34.00	3.00	OR26203617-08	36.17	2.62
OR30003150-08	31.50	3.00	OR40003400-08	34.00	4.00	OR17803627-08	36.27	1.78
OR35003170-10	31.70	3.50	OR35003400-08	34.00	3.50	OR30003650-08	36.50	3.00
OR35003170-08	31.70	3.50	OR50003400-08	34.00	5.00	OR25003650-08	36.50	2.50
OR20003200-08	32.00	2.00	OR25003400-08	34.00	2.50	OR40003700-08	37.00	4.00
OR40003200-08	32.00	4.00	OR53303429-08	34.29	5.33	OR30003700-08	37.00	3.00
OR32003200-08	32.00	3.20	OR31003440-11	34.40	3.10	OR20003700-08	37.00	2.00
OR50003200-08	32.00	5.00	OR31003440-10	34.40	3.10	OR10003700-08	37.00	1.00
OR10003200-08	32.00	1.00	OR40003450-08	34.50	4.00	OR15003700-08	37.00	1.50
OR30003200-08	32.00	3.00	OR30003450-08	34.50	3.00	OR50003700-08	37.00	5.00
OR35003200-08	32.00	3.50	OR35303452-08	34.52	3.53	OR35003700-08	37.00	3.50
OR25003200-08	32.00	2.50	OR35303452-10	34.52	3.53	OR25003700-08	37.00	2.50

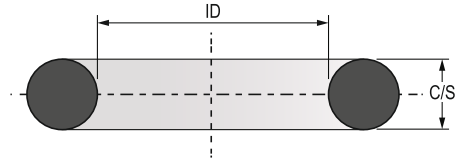
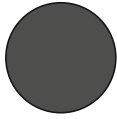

Max Spare Part No.	ID (mm)	C/S (mm)	Max Spare Part No.	ID (mm)	C/S (mm)	Max Spare Part No.	ID (mm)	C/S (mm)
OR16003710-08	37.10	1.60	OR30003950-08	39.50	3.00	OR40004200-08	42.00	4.00
OR31003740-10	37.40	3.10	OR35303970-10	39.70	3.53	OR45004200-08	42.00	4.50
OR35003740-08	37.40	3.50	OR35303970-08	39.70	3.53	OR32004200-08	42.00	3.20
OR53303747-08	37.47	5.33	OR30004000-08	40.00	3.00	OR25004200-08	42.00	2.50
OR53303747-10	37.47	5.33	OR25004000-10	40.00	2.50	OR15004200-08	42.00	1.50
OR25003750-08	37.50	2.50	OR50004000-08	40.00	5.00	OR30004250-08	42.50	3.00
OR30003750-08	37.50	3.00	OR15004000-08	40.00	1.50	OR26204252-10	42.52	2.62
OR35303769-08	37.69	3.53	OR55004000-08	40.00	5.50	OR26204252-08	42.52	2.62
OR35303769-10	37.69	3.53	OR10004000-08	40.00	1.00	OR35304286-08	42.86	3.53
OR35303769-11	37.69	3.53	OR35004000-10	40.00	3.50	OR25004300-08	43.00	2.50
OR35003770-10	37.70	3.50	OR30004000-10	40.00	3.00	OR50004300-08	43.00	5.00
OR26203777-08	37.77	2.62	OR53004000-08	40.00	5.30	OR30004300-08	43.00	3.00
OR17803782-10	37.82	1.78	OR40004000-08	40.00	4.00	OR40004300-08	43.00	4.00
OR17803782-08	37.82	1.78	OR20004000-08	40.00	2.00	OR20004300-08	43.00	2.00
OR25003800-08	38.00	2.50	OR25004000-08	40.00	2.50	OR35304350-10	43.50	3.53
OR50003800-08	38.00	5.00	OR30004020-08	40.20	3.00	OR35504370-10	43.70	3.55
OR45003800-08	38.00	4.50	OR15004050-08	40.50	1.50	OR53304382-08	43.82	5.33
OR40003800-08	38.00	4.00	OR53304064-08	40.64	5.33	OR20004400-08	44.00	2.00
OR55003800-08	38.00	5.50	OR35304087-08	40.87	3.53	OR55004400-08	44.00	5.50
OR30003800-08	38.00	3.00	OR26204094-08	40.94	2.62	OR24004400-08	44.00	2.40
OR15003800-08	38.00	1.50	OR17804100-10	41.00	1.78	OR25004400-08	44.00	2.50
OR35003800-08	38.00	3.50	OR45004100-08	41.00	4.50	OR50004400-08	44.00	5.00
OR20003800-08	38.00	2.00	OR55004100-08	41.00	5.50	OR40004400-08	44.00	4.00
OR30003870-08	38.70	3.00	OR20004100-08	41.00	2.00	OR30004400-10	44.00	3.00
OR30003900-08	39.00	3.00	OR30004100-08	41.00	3.00	OR30004400-08	44.00	3.00
OR35003900-08	39.00	3.50	OR17804100-08	41.00	1.78	OR35304404-08	44.04	3.53
OR35003900-10	39.00	3.50	OR25004100-08	41.00	2.50	OR35304404-10	44.04	3.53
OR20003900-08	39.00	2.00	OR40004100-08	41.00	4.00	OR26204412-08	44.12	2.62
OR15003900-08	39.00	1.50	OR35304128-10	41.28	3.53	OR26204412-10	44.12	2.62
OR55003900-08	39.00	5.50	OR35304128-08	41.28	3.53	OR17804417-08	44.17	1.78
OR40003900-08	39.00	4.00	OR30004150-08	41.50	3.00	OR57004430-08	44.30	5.70
OR25003900-08	39.00	2.50	OR26204170-10	41.70	2.62	OR31004440-10	44.40	3.10
OR26203934-08	39.34	2.62	OR20004200-08	42.00	2.00	OR35304445-10	44.45	3.53
OR26203934-10	39.34	2.62	OR30004200-08	42.00	3.00	OR30004450-08	44.50	3.00
OR31003940-10	39.40	3.10	OR35004200-08	42.00	3.50	OR18004450-08	44.50	1.80
OR17803945-08	39.45	1.78	OR50004200-08	42.00	5.00	OR55004450-08	44.50	5.50
OR20003950-08	39.50	2.00	OR60004200-08	42.00	6.00	OR35304453-10	44.53	3.53

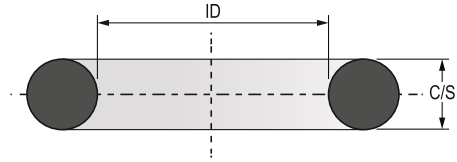
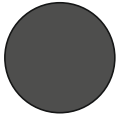

Max Spare Part No.	ID (mm)	C/S (mm)	Max Spare Part No.	ID (mm)	C/S (mm)	Max Spare Part No.	ID (mm)	C/S (mm)
OR25004500-08	45.00	2.50	OR35304722-10	47.22	3.53	OR45005000-08	50.00	4.50
OR30004500-08	45.00	3.00	OR26204729-08	47.29	2.62	OR15005000-08	50.00	1.50
OR35004500-08	45.00	3.50	OR17804735-08	47.35	1.78	OR40005000-08	50.00	4.00
OR45004500-08	45.00	4.50	OR19004800-10	48.00	1.90	OR53305017-08	50.17	5.33
OR70004500-08	45.00	7.00	OR35004800-08	48.00	3.50	OR36005030-10	50.30	3.60
OR55004500-08	45.00	5.50	OR25004800-10	48.00	2.50	OR35305039-08	50.39	3.53
OR60004500-08	45.00	6.00	OR50004800-08	48.00	5.00	OR35305039-11	50.39	3.53
OR40004500-08	45.00	4.00	OR40004800-08	48.00	4.00	OR26205047-10	50.47	2.62
OR50004500-08	45.00	5.00	OR30004800-08	48.00	3.00	OR26205047-08	50.47	2.62
OR18004500-08	45.00	1.80	OR35004800-10	48.00	3.50	OR17805052-08	50.52	1.78
OR20004500-08	45.00	2.00	OR25004800-08	48.00	2.50	OR35305080-10	50.80	3.53
OR35304536-10	45.36	3.53	OR60004800-08	48.00	6.00	OR30005100-08	51.00	3.00
OR50004550-08	45.50	5.00	OR20004800-08	48.00	2.00	OR50005100-08	51.00	5.00
OR26204569-08	45.69	2.62	OR33204850-10	48.50	3.32	OR25005100-08	51.00	2.50
OR35004570-10	45.70	3.50	OR57004860-10	48.60	5.70	OR40005100-08	51.00	4.00
OR20004600-08	46.00	2.00	OR31004880-10	48.80	3.10	OR20005100-08	51.00	2.00
OR50004600-08	46.00	5.00	OR26204890-10	48.90	2.62	OR35005100-08	51.00	3.50
OR18004600-08	46.00	1.80	OR26204890-08	48.90	2.62	OR35005150-08	51.50	3.50
OR15004600-08	46.00	1.50	OR20004900-08	49.00	2.00	OR20005150-08	51.50	2.00
OR35004600-10	46.00	3.50	OR35004900-08	49.00	3.50	OR24005160-08	51.60	2.40
OR35004600-08	46.00	3.50	OR35004900-10	49.00	3.50	OR57005160-10	51.60	5.70
OR30004600-08	46.00	3.00	OR40004900-08	49.00	4.00	OR25005200-08	52.00	2.50
OR40004600-08	46.00	4.00	OR30004900-08	49.00	3.00	OR50005200-08	52.00	5.00
OR25004600-08	46.00	2.50	OR50004900-08	49.00	5.00	OR60005200-08	52.00	6.00
OR35004650-10	46.50	3.50	OR15004900-08	49.00	1.50	OR20005200-08	52.00	2.00
OR26204678-08	46.78	2.62	OR25004900-08	49.00	2.50	OR18005200-08	52.00	1.80
OR26204678-10	46.78	2.62	OR57004920-08	49.20	5.70	OR35005200-08	52.00	3.50
OR53304699-08	46.99	5.33	OR31004940-10	49.40	3.10	OR40005200-08	52.00	4.00
OR40004700-08	47.00	4.00	OR20004950-10	49.50	2.00	OR30005200-08	52.00	3.00
OR15004700-08	47.00	1.50	OR30004950-08	49.50	3.00	OR26205207-08	52.07	2.62
OR20004700-10	47.00	2.00	OR20005000-08	50.00	2.00	OR57005230-10	52.30	5.70
OR30004700-08	47.00	3.00	OR25005000-08	50.00	2.50	OR57005230-08	52.30	5.70
OR50004700-08	47.00	5.00	OR30005000-08	50.00	3.00	OR25005300-08	53.00	2.50
OR20004700-08	47.00	2.00	OR60005000-08	50.00	6.00	OR40005300-08	53.00	4.00
OR25004700-08	47.00	2.50	OR35005000-08	50.00	3.50	OR20005300-08	53.00	2.00
OR35304722-08	47.22	3.53	OR55005000-08	50.00	5.50	OR50005300-08	53.00	5.00
OR35304722-11	47.22	3.53	OR50005000-08	50.00	5.00	OR60005300-08	53.00	6.00

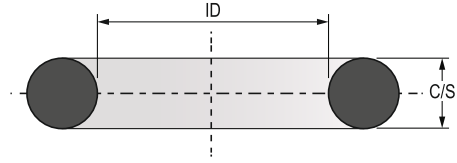
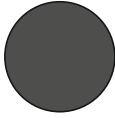

Max Spare Part No.	ID (mm)	C/S (mm)	Max Spare Part No.	ID (mm)	C/S (mm)	Max Spare Part No.	ID (mm)	C/S (mm)
OR55005300-08	53.00	5.50	OR25005600-08	56.00	2.50	OR30005850-08	58.50	3.00
OR30005300-08	53.00	3.00	OR30005600-08	56.00	3.00	OR35305874-08	58.74	3.53
OR35005300-08	53.00	3.50	OR60005600-08	56.00	6.00	OR25005900-08	59.00	2.50
OR53305334-08	53.34	5.33	OR45005600-08	56.00	4.50	OR31005900-10	59.00	3.10
OR31005340-10	53.40	3.10	OR35005600-08	56.00	3.50	OR40005900-08	59.00	4.00
OR35305357-08	53.57	3.53	OR17505600-08	56.00	1.75	OR20005900-08	59.00	2.00
OR35305357-10	53.57	3.53	OR40005600-08	56.00	4.00	OR35005900-08	59.00	3.50
OR35305357-11	53.57	3.53	OR20005600-08	56.00	2.00	OR30005900-08	59.00	3.00
OR26205364-08	53.64	2.62	OR50005600-08	56.00	5.00	OR31005940-10	59.40	3.10
OR17805370-08	53.70	1.78	OR53305652-08	56.52	5.33	OR30005950-08	59.50	3.00
OR31005380-10	53.80	3.10	OR35305674-08	56.74	3.53	OR57005960-10	59.60	5.70
OR35005400-08	54.00	3.50	OR35305674-10	56.74	3.53	OR57005960-08	59.60	5.70
OR33005400-08	54.00	3.30	OR35305674-11	56.74	3.53	OR53305969-08	59.69	5.33
OR15005400-08	54.00	1.50	OR26205682-08	56.82	2.62	OR35305992-10	59.92	3.53
OR55005400-08	54.00	5.50	OR26205682-10	56.82	2.62	OR35305992-08	59.92	3.53
OR25005400-08	54.00	2.50	OR17805687-08	56.87	1.78	OR26205999-08	59.99	2.62
OR40005400-08	54.00	4.00	OR25005700-08	57.00	2.50	OR15006000-08	60.00	1.50
OR50005400-08	54.00	5.00	OR30005700-08	57.00	3.00	OR30006000-08	60.00	3.00
OR180054000-08	54.00	1.80	OR35005700-08	57.00	3.50	OR60006000-08	60.00	6.00
OR20005400-08	54.00	2.00	OR30005700-10	57.00	3.00	OR35006000-10	60.00	3.50
OR30005400-08	54.00	3.00	OR20005700-08	57.00	2.00	OR55006000-08	60.00	5.50
OR31005440-10	54.40	3.10	OR40005700-08	57.00	4.00	OR50006000-10	60.00	5.00
OR20005443-08	54.43	2.00	OR50005700-08	57.00	5.00	OR35006000-08	60.00	3.50
OR30005450-08	54.50	3.00	OR35305715-10	57.15	3.53	OR40006000-08	60.00	4.00
OR57005460-08	54.60	5.70	OR31005740-10	57.40	3.10	OR50006000-08	60.00	5.00
OR25005500-08	55.00	2.50	OR31005750-10	57.50	3.10	OR70006000-08	60.00	7.00
OR30005500-08	55.00	3.00	OR31005750-08	57.50	3.10	OR25006000-08	60.00	2.50
OR40005500-08	55.00	4.00	OR25005800-08	58.00	2.50	OR20006000-08	60.00	2.00
OR35005500-10	55.00	3.50	OR35005800-08	58.00	3.50	OR17806005-08	60.05	1.78
OR55005500-08	55.00	5.50	OR40005800-08	58.00	4.00	OR17506032-08	60.32	1.75
OR60005500-08	55.00	6.00	OR60005800-08	58.00	6.00	OR25006100-08	61.00	2.50
OR15005500-08	55.00	1.50	OR20005800-08	58.00	2.00	OR40006100-08	61.00	4.00
OR35005500-08	55.00	3.50	OR50005800-08	58.00	5.00	OR20006100-08	61.00	2.00
OR50005500-08	55.00	5.00	OR30005800-08	58.00	3.00	OR35006100-08	61.00	3.50
OR20005500-08	55.00	2.00	OR20005815-08	58.15	2.00	OR50006100-08	61.00	5.00
OR26205525-08	55.25	2.62	OR26205842-10	58.42	2.62	OR30006100-08	61.00	3.00
OR30005550-08	55.50	3.00	OR26205842-08	58.42	2.62	OR55006150-08	61.50	5.50

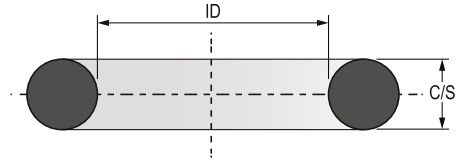
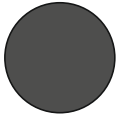

Max Spare Part No.	ID (mm)	C/S (mm)	Max Spare Part No.	ID (mm)	C/S (mm)	Max Spare Part No.	ID (mm)	C/S (mm)
OR26206160-08	61.60	2.62	OR30006450-08	64.50	3.00	OR35006700-08	67.00	3.50
OR35306190-10	61.90	3.53	OR57006460-08	64.60	5.70	OR55006700-08	67.00	5.50
OR35306190-08	61.90	3.53	OR57006460-10	64.60	5.70	OR40006700-08	67.00	4.00
OR50006200-08	62.00	5.00	OR20006477-10	64.77	2.00	OR30006700-08	67.00	3.00
OR60006200-08	62.00	6.00	OR20006477-08	64.77	2.00	OR50006700-08	67.00	5.00
OR25006200-08	62.00	2.50	OR26206477-10	64.77	2.62	OR26206795-08	67.95	2.62
OR40006200-08	62.00	4.00	OR26206477-08	64.77	2.62	OR35006800-08	68.00	3.50
OR30006200-08	62.00	3.00	OR15006500-08	65.00	1.50	OR40006800-08	68.00	4.00
OR20006200-08	62.00	2.00	OR53006500-08	65.00	5.30	OR20006800-08	68.00	2.00
OR31006240-10	62.40	3.10	OR60006500-08	65.00	6.00	OR50006800-08	68.00	5.00
OR53306287-08	62.87	5.33	OR20006500-08	65.00	2.00	OR25006800-08	68.00	2.50
OR25006300-08	63.00	2.50	OR30006500-08	65.00	3.00	OR30006800-08	68.00	3.00
OR30006300-08	63.00	3.00	OR40006500-08	65.00	4.00	OR60006800-08	68.00	6.00
OR20006300-08	63.00	2.00	OR20006500-10	65.00	2.00	OR25006900-08	69.00	2.50
OR60006300-08	63.00	6.00	OR25006500-08	65.00	2.50	OR20006900-08	69.00	2.00
OR40006300-08	63.00	4.00	OR50006500-10	65.00	5.00	OR45006900-08	69.00	4.50
OR15006300-08	63.00	1.50	OR45006500-08	65.00	4.50	OR30006900-08	69.00	3.00
OR35006300-10	63.00	3.50	OR55006500-08	65.00	5.50	OR20006900-10	69.00	2.00
OR50006300-08	63.00	5.00	OR50006500-08	65.00	5.00	OR40006900-08	69.00	4.00
OR35306309-10	63.09	3.53	OR35306509-10	65.09	3.53	OR55006900-08	69.00	5.50
OR35306309-08	63.09	3.53	OR35306509-08	65.09	3.53	OR15006900-08	69.00	1.50
OR26206317-10	63.17	2.62	OR17806540-08	65.40	1.78	OR57006920-10	69.20	5.70
OR26206317-08	63.17	2.62	OR40006600-08	66.00	4.00	OR57006920-08	69.20	5.70
OR17806322-08	63.22	1.78	OR30006600-08	66.00	3.00	OR53306922-08	69.22	5.33
OR50006350-08	63.50	5.00	OR25006600-08	66.00	2.50	OR31006940-10	69.40	3.10
OR31706350-08	63.50	3.17	OR20006600-10	66.00	2.00	OR35306944-10	69.44	3.53
OR18006380-08	63.80	1.80	OR20006600-08	66.00	2.00	OR35306944-08	69.44	3.53
OR15006400-08	64.00	1.50	OR53306604-08	66.04	5.33	OR35306944-11	69.44	3.53
OR20006400-08	64.00	2.00	OR35306627-10	66.27	3.53	OR30006950-08	69.50	3.00
OR50006400-08	64.00	5.00	OR35306627-08	66.27	3.53	OR26206952-08	69.52	2.62
OR35006400-08	64.00	3.50	OR26206634-08	66.34	2.62	OR17806957-08	69.57	1.78
OR30006400-08	64.00	3.00	OR26206635-10	66.35	2.62	OR50007000-08	70.00	5.00
OR25006400-08	64.00	2.50	OR17806640-08	66.40	1.78	OR55007000-08	70.00	5.50
OR40006400-08	64.00	4.00	OR50006650-08	66.50	5.00	OR57007000-08	70.00	5.70
OR57006430-08	64.30	5.70	OR57006660-08	66.60	5.70	OR60007000-08	70.00	6.00
OR57006430-10	64.30	5.70	OR20006700-08	67.00	2.00	OR25007000-08	70.00	2.50
OR31006440-10	64.40	3.10	OR25006700-08	67.00	2.50	OR36007000-10	70.00	3.60

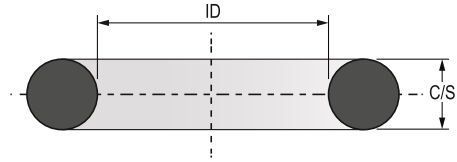
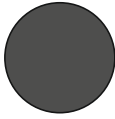

Max Spare Part No.	ID (mm)	C/S (mm)	Max Spare Part No.	ID (mm)	C/S (mm)	Max Spare Part No.	ID (mm)	C/S (mm)
OR35007000-10	70.00	3.50	OR50007400-08	74.00	5.00	OR50007800-08	78.00	5.00
OR35007000-08	70.00	3.50	OR20007400-08	74.00	2.00	OR60007800-08	78.00	6.00
OR40007000-08	70.00	4.00	OR35007400-08	74.00	3.50	OR35007800-10	78.00	3.50
OR20007000-10	70.00	2.00	OR57007420-08	74.20	5.70	OR40007800-08	78.00	4.00
OR30007000-08	70.00	3.00	OR26207430-08	74.30	2.62	OR31007800-10	78.00	3.10
OR20007000-08	70.00	2.00	OR31007440-10	74.40	3.10	OR30007800-08	78.00	3.00
OR40007100-08	71.00	4.00	OR30007450-08	74.50	3.00	OR53007800-10	78.00	5.30
OR50007100-08	71.00	5.00	OR57007460-08	74.60	5.70	OR20007800-08	78.00	2.00
OR25007100-08	71.00	2.50	OR31707470-08	74.70	3.17	OR30007850-10	78.50	3.00
OR30007100-08	71.00	3.00	OR25007500-08	75.00	2.50	OR30007850-08	78.50	3.00
OR20007100-08	71.00	2.00	OR35007500-08	75.00	3.50	OR53307874-08	78.74	5.33
OR26207118-08	71.18	2.62	OR15007500-08	75.00	1.50	OR53307874-10	78.74	5.33
OR35307144-10	71.44	3.53	OR55007500-08	75.00	5.50	OR35307897-10	78.97	3.53
OR35307144-08	71.44	3.53	OR60007500-08	75.00	6.00	OR35307897-08	78.97	3.53
OR25007160-08	71.60	2.50	OR50007500-08	75.00	5.00	OR50007900-08	79.00	5.00
OR60007200-08	72.00	6.00	OR30007500-08	75.00	3.00	OR40007900-08	79.00	4.00
OR30007200-08	72.00	3.00	OR20007500-08	75.00	2.00	OR30007900-08	79.00	3.00
OR50007200-08	72.00	5.00	OR40007500-08	75.00	4.00	OR20007900-08	79.00	2.00
OR57007200-10	72.00	5.70	OR53307557-08	75.57	5.33	OR17807900-08	79.00	1.78
OR35007200-08	72.00	3.50	OR35307579-08	75.79	3.53	OR57007920-10	79.20	5.70
OR40007200-08	72.00	4.00	OR26207587-08	75.87	2.62	OR57007920-08	79.20	5.70
OR20007200-08	72.00	2.00	OR26207587-10	75.87	2.62	OR31007940-10	79.40	3.10
OR53307239-08	72.39	5.33	OR17807592-08	75.92	1.78	OR30007950-08	79.50	3.00
OR53307239-10	72.39	5.33	OR20007600-08	76.00	2.00	OR57007960-10	79.60	5.70
OR35307262-08	72.62	3.53	OR35007600-08	76.00	3.50	OR53307973-10	79.73	5.33
OR35307262-11	72.62	3.53	OR30007600-08	76.00	3.00	OR53307973-08	79.73	5.33
OR26207269-08	72.69	2.62	OR25007600-08	76.00	2.50	OR25008000-08	80.00	2.50
OR17807275-08	72.75	1.78	OR40007600-08	76.00	4.00	OR50008000-08	80.00	5.00
OR30007300-08	73.00	3.00	OR50007600-08	76.00	5.00	OR40008000-08	80.00	4.00
OR40007300-08	73.00	4.00	OR20007700-08	77.00	2.00	OR45008000-08	80.00	4.50
OR50007300-08	73.00	5.00	OR35007700-08	77.00	3.50	OR55008000-08	80.00	5.50
OR20007300-08	73.00	2.00	OR40007700-08	77.00	4.00	OR60008000-08	80.00	6.00
OR25007300-08	73.00	2.50	OR30007700-08	77.00	3.00	OR35008000-08	80.00	3.50
OR35007300-10	73.00	3.50	OR25007700-08	77.00	2.50	OR15008000-08	80.00	1.50
OR30007400-08	74.00	3.00	OR26207750-10	77.50	2.62	OR20008000-08	80.00	2.00
OR40007400-08	74.00	4.00	OR26207750-08	77.50	2.62	OR30008000-08	80.00	3.00
OR25007400-08	74.00	2.50	OR35007800-08	78.00	3.50	OR26208060-08	80.60	2.62

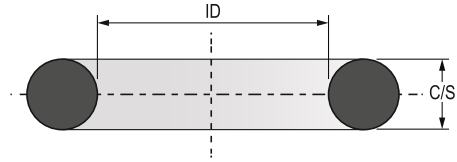
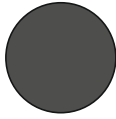

Max Spare Part No.	ID (mm)	C/S (mm)	Max Spare Part No.	ID (mm)	C/S (mm)	Max Spare Part No.	ID (mm)	C/S (mm)
OR20008100-08	81.00	2.00	OR40008500-08	85.00	4.00	OR57008920-08	89.20	5.70
OR30008100-08	81.00	3.00	OR30008500-08	85.00	3.00	OR31008940-10	89.40	3.10
OR15008100-08	81.00	1.50	OR25008500-08	85.00	2.50	OR57008960-10	89.60	5.70
OR35008100-08	81.00	3.50	OR53308509-08	85.09	5.33	OR53308969-08	89.69	5.33
OR50008100-08	81.00	5.00	OR35308532-10	85.32	3.53	OR60009000-08	90.00	6.00
OR34008134-10	81.34	3.40	OR35308532-11	85.32	3.53	OR35009000-10	90.00	3.50
OR53308192-08	81.92	5.33	OR35308532-08	85.32	3.53	OR30009000-08	90.00	3.00
OR20008200-08	82.00	2.00	OR17808534-08	85.34	1.78	OR40009000-08	90.00	4.00
OR25008200-08	82.00	2.50	OR40008600-08	86.00	4.00	OR55009000-08	90.00	5.50
OR50008200-08	82.00	5.00	OR20008600-08	86.00	2.00	OR25009000-08	90.00	2.50
OR30008200-08	82.00	3.00	OR30008600-08	86.00	3.00	OR35009000-08	90.00	3.50
OR40008200-08	82.00	4.00	OR35008600-08	86.00	3.50	OR20009000-08	90.00	2.00
OR35308214-10	82.14	3.53	OR53308700-10	87.00	5.33	OR50009000-08	90.00	5.00
OR35308214-08	82.14	3.53	OR20008700-08	87.00	2.00	OR70009000-08	90.00	7.00
OR26208222-08	82.22	2.62	OR40008700-08	87.00	4.00	OR25009100-08	91.00	2.50
OR17808227-08	82.27	1.78	OR30008700-08	87.00	3.00	OR35009100-10	91.00	3.50
OR60008300-08	83.00	6.00	OR15008700-08	87.00	1.50	OR45009100-10	91.00	4.50
OR35008300-08	83.00	3.50	OR35308732-10	87.32	3.53	OR40009100-08	91.00	4.00
OR25008300-08	83.00	2.50	OR50008750-08	87.50	5.00	OR30009100-08	91.00	3.00
OR30008300-08	83.00	3.00	OR60008800-08	88.00	6.00	OR50009100-08	91.00	5.00
OR20008300-08	83.00	2.00	OR15008800-08	88.00	1.50	OR53409144-10	91.44	5.34
OR26208380-08	83.80	2.62	OR40008800-08	88.00	4.00	OR53309144-08	91.44	5.33
OR35008400-08	84.00	3.50	OR30008800-08	88.00	3.00	OR35309167-08	91.67	3.53
OR40008400-08	84.00	4.00	OR20008800-08	88.00	2.00	OR35309167-10	91.67	3.53
OR20008400-08	84.00	2.00	OR50008800-08	88.00	5.00	OR17809170-08	91.70	1.78
OR50008400-08	84.00	5.00	OR25008800-08	88.00	2.50	OR60009200-08	92.00	6.00
OR30008400-08	84.00	3.00	OR53308827-08	88.27	5.33	OR20009200-08	92.00	2.00
OR57008430-08	84.30	5.70	OR35308827-08	88.27	3.53	OR50009200-08	92.00	5.00
OR31008440-10	84.40	3.10	OR35308849-08	88.49	3.53	OR40009200-08	92.00	4.00
OR30008450-08	84.50	3.00	OR35308849-10	88.49	3.53	OR25009200-08	92.00	2.50
OR57008460-10	84.60	5.70	OR26208857-08	88.57	2.62	OR30009200-08	92.00	3.00
OR57008460-08	84.60	5.70	OR17808862-08	88.62	1.78	OR20009300-08	93.00	2.00
OR55008500-08	85.00	5.50	OR50008900-08	89.00	5.00	OR35009300-08	93.00	3.50
OR52008500-08	85.00	5.20	OR50008900-10	89.00	5.00	OR30009300-08	93.00	3.00
OR60008500-08	85.00	6.00	OR30008900-10	89.00	3.00	OR60009300-08	93.00	6.00
OR20008500-08	85.00	2.00	OR30008900-08	89.00	3.00	OR40009300-08	93.00	4.00
OR50008500-08	85.00	5.00	OR55008900-08	89.00	5.50	OR35009400-08	94.00	3.50

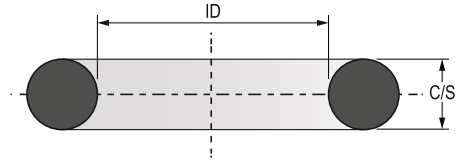
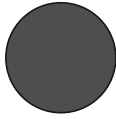

Max Spare Part No.	ID (mm)	C/S (mm)	Max Spare Part No.	ID (mm)	C/S (mm)	Max Spare Part No.	ID (mm)	C/S (mm)
OR60009400-08	94.00	6.00	OR30009800-08	98.00	3.00	OR26210127-10	101.27	2.62
OR25009400-08	94.00	2.50	OR20009800-08	98.00	2.00	OR26210127-08	101.27	2.62
OR40009400-08	94.00	4.00	OR25009800-08	98.00	2.50	OR17810132-08	101.32	1.78
OR30009400-08	94.00	3.00	OR50009800-08	98.00	5.00	OR35010200-08	102.00	3.50
OR20009400-08	94.00	2.00	OR60009800-08	98.00	6.00	OR50010200-08	102.00	5.00
OR31009440-10	94.40	3.10	OR35309802-08	98.02	3.53	OR25010200-08	102.00	2.50
OR30009450-08	94.50	3.00	OR35309802-10	98.02	3.53	OR30010200-08	102.00	3.00
OR57009460-10	94.60	5.70	OR17809805-08	98.05	1.78	OR20010200-08	102.00	2.00
OR57009460-08	94.60	5.70	OR35009850-08	98.50	3.50	OR40010200-08	102.00	4.00
OR53309462-08	94.62	5.33	OR30009900-08	99.00	3.00	OR20010300-08	103.00	2.00
OR35309484-10	94.84	3.53	OR35009900-08	99.00	3.50	OR30010300-10	103.00	3.00
OR35309484-08	94.84	3.53	OR30009900-10	99.00	3.00	OR60010300-08	103.00	6.00
OR26209492-08	94.92	2.62	OR57009930-08	99.30	5.70	OR30010300-08	103.00	3.00
OR17809497-08	94.97	1.78	OR57009930-10	99.30	5.70	OR40010400-08	104.00	4.00
OR20009500-08	95.00	2.00	OR31009940-10	99.40	3.10	OR25010400-08	104.00	2.50
OR25009500-08	95.00	2.50	OR30009950-08	99.50	3.00	OR30010400-10	104.00	3.00
OR30009500-08	95.00	3.00	OR30009950-10	99.50	3.00	OR50010400-08	104.00	5.00
OR45009500-08	95.00	4.50	OR57009960-10	99.60	5.70	OR17810400-08	104.00	1.78
OR30009500-10	95.00	3.00	OR30010000-08	100.00	3.00	OR30010400-08	104.00	3.00
OR60009500-08	95.00	6.00	OR32010000-08	100.00	3.20	OR53310414-08	104.14	5.33
OR50009500-08	95.00	5.00	OR53310000-10	100.00	5.33	OR57010430-08	104.30	5.70
OR35009500-08	95.00	3.50	OR53310000-08	100.00	5.33	OR35310437-08	104.37	3.53
OR40009500-08	95.00	4.00	OR25010000-08	100.00	2.50	OR35310437-10	104.37	3.53
OR25009600-08	96.00	2.50	OR55010000-08	100.00	5.50	OR31010440-10	104.40	3.10
OR50009600-08	96.00	5.00	OR50010000-10	100.00	5.00	OR32010440-08	104.40	3.20
OR35009600-08	96.00	3.50	OR15010000-08	100.00	1.50	OR30010500-08	105.00	3.00
OR30009600-08	96.00	3.00	OR35010000-08	100.00	3.50	OR25010500-08	105.00	2.50
OR40009600-08	96.00	4.00	OR100010000-08	100.00	10.00	OR40010500-08	105.00	4.00
OR20009600-08	96.00	2.00	OR70010000-08	100.00	7.00	OR60010500-08	105.00	6.00
OR25009700-08	97.00	2.50	OR20010000-08	100.00	2.00	OR50010500-08	105.00	5.00
OR20009700-08	97.00	2.00	OR60010000-08	100.00	6.00	OR20010500-08	105.00	2.00
OR30009700-08	97.00	3.00	OR50010000-08	100.00	5.00	OR30010600-08	106.00	3.00
OR50009700-08	97.00	5.00	OR40010000-08	100.00	4.00	OR60010600-08	106.00	6.00
OR40009700-08	97.00	4.00	OR53310097-08	100.97	5.33	OR35010600-08	106.00	3.50
OR35009700-10	97.00	3.50	OR53310097-10	100.97	5.33	OR20010600-08	106.00	2.00
OR53309779-08	97.79	5.33	OR30010100-08	101.00	3.00	OR25010700-08	107.00	2.50
OR40009800-08	98.00	4.00	OR35310119-08	101.19	3.53	OR35010700-08	107.00	3.50

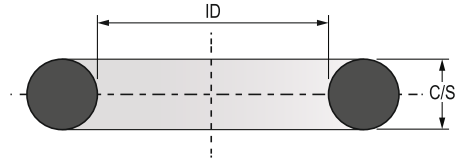
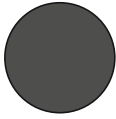

Max Spare Part No.	ID (mm)	C/S (mm)	Max Spare Part No.	ID (mm)	C/S (mm)	Max Spare Part No.	ID (mm)	C/S (mm)
OR50010700-08	107.00	5.00	OR50011200-08	112.00	5.00	OR40011700-08	117.00	4.00
OR20010700-08	107.00	2.00	OR40011200-08	112.00	4.00	OR30011700-08	117.00	3.00
OR40010700-08	107.00	4.00	OR30011200-08	112.00	3.00	OR35311707-08	117.07	3.53
OR53310732-08	107.32	5.33	OR35011200-08	112.00	3.50	OR17811710-08	117.10	1.78
OR35310754-08	107.54	3.53	OR35011300-08	113.00	3.50	OR20011800-08	118.00	2.00
OR26210762-10	107.62	2.62	OR50011300-08	113.00	5.00	OR60011800-08	118.00	6.00
OR26210762-08	107.62	2.62	OR40011300-08	113.00	4.00	OR40011800-08	118.00	4.00
OR17810767-08	107.67	1.78	OR60011300-08	113.00	6.00	OR30011800-08	118.00	3.00
OR35010800-10	108.00	3.50	OR31011350-10	113.50	3.10	OR50011800-08	118.00	5.00
OR60010800-08	108.00	6.00	OR69911367-08	113.67	6.99	OR35011850-08	118.50	3.50
OR25010800-08	108.00	2.50	OR53311367-10	113.67	5.33	OR30011900-08	119.00	3.00
OR35010800-08	108.00	3.50	OR53311367-08	113.67	5.33	OR57011920-08	119.20	5.70
OR20010800-08	108.00	2.00	OR35311389-08	113.89	3.53	OR31011940-10	119.40	3.10
OR30010800-08	108.00	3.00	OR53311389-10	113.89	5.33	OR57011960-10	119.60	5.70
OR50010800-08	108.00	5.00	OR53311389-08	113.89	5.33	OR25012000-10	120.00	2.50
OR30010900-08	109.00	3.00	OR26211397-08	113.97	2.62	OR30012000-08	120.00	3.00
OR30010900-10	109.00	3.00	OR40011400-08	114.00	4.00	OR25012000-08	120.00	2.50
OR40010900-08	109.00	4.00	OR30011400-08	114.00	3.00	OR55012000-08	120.00	5.50
OR35010900-08	109.00	3.50	OR17811402-08	114.02	1.78	OR20012000-08	120.00	2.00
OR57010930-08	109.30	5.70	OR57011430-10	114.30	5.70	OR40012000-08	120.00	4.00
OR31010940-10	109.40	3.10	OR57011430-08	114.30	5.70	OR30012000-10	120.00	3.00
OR57010960-08	109.60	5.70	OR31011440-10	114.40	3.10	OR60012000-08	120.00	6.00
OR15011000-08	110.00	1.50	OR30011450-08	114.50	3.00	OR50012000-08	120.00	5.00
OR60011000-08	110.00	6.00	OR57011470-10	114.70	5.70	OR53312002-08	120.02	5.33
OR20011000-08	110.00	2.00	OR50011500-08	115.00	5.00	OR69912019-08	120.19	6.99
OR50011000-10	110.00	5.00	OR25011500-08	115.00	2.50	OR35312024-10	120.24	3.53
OR25011000-08	110.00	2.50	OR20011500-08	115.00	2.00	OR35312024-08	120.24	3.53
OR55011000-08	110.00	5.50	OR60011500-08	115.00	6.00	OR26212032-08	120.32	2.62
OR40011000-08	110.00	4.00	OR57011500-08	115.00	5.70	OR17812037-08	120.37	1.78
OR30011000-08	110.00	3.00	OR40011500-08	115.00	4.00	OR45012050-08	120.50	4.50
OR35011000-08	110.00	3.50	OR55011500-08	115.00	5.50	OR25012200-08	122.00	2.50
OR50011000-08	110.00	5.00	OR35011500-08	115.00	3.50	OR53012200-08	122.00	5.30
OR53311049-08	110.49	5.33	OR30011500-08	115.00	3.00	OR20012200-08	122.00	2.00
OR35311072-10	110.72	3.53	OR20011600-08	116.00	2.00	OR40012200-08	122.00	4.00
OR35311072-08	110.72	3.53	OR50011600-08	116.00	5.00	OR30012200-08	122.00	3.00
OR17811074-08	110.74	1.78	OR53311684-08	116.84	5.33	OR35012200-08	122.00	3.50
OR20011200-08	112.00	2.00	OR69911684-08	116.84	6.99	OR40012300-08	123.00	4.00

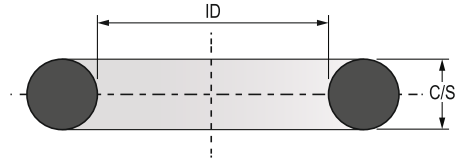
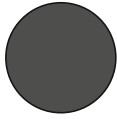

Max Spare Part No.	ID (mm)	C/S (mm)	Max Spare Part No.	ID (mm)	C/S (mm)	Max Spare Part No.	ID (mm)	C/S (mm)
OR50012300-08	123.00	5.00	OR55012900-08	129.00	5.50	OR20013500-08	135.00	2.00
OR69912319-08	123.19	6.99	OR57012930-08	129.30	5.70	OR50013500-08	135.00	5.00
OR53312319-08	123.19	5.33	OR17812940-08	129.40	1.78	OR25013500-08	135.00	2.50
OR35312342-08	123.42	3.53	OR31012940-10	129.40	3.10	OR17813576-08	135.76	1.78
OR17812344-08	123.44	1.78	OR53312954-08	129.54	5.33	OR69913589-08	135.89	6.99
OR40012400-08	124.00	4.00	OR69912954-08	129.54	6.99	OR53313589-08	135.89	5.33
OR30012400-10	124.00	3.00	OR35312977-10	129.77	3.53	OR30013600-08	136.00	3.00
OR32012400-08	124.00	3.20	OR35312977-08	129.77	3.53	OR60013600-08	136.00	6.00
OR57012430-08	124.30	5.70	OR30013000-08	130.00	3.00	OR35313612-08	136.12	3.53
OR31012440-10	124.40	3.10	OR40013000-08	130.00	4.00	OR35313612-10	136.12	3.53
OR35312442-10	124.42	3.53	OR25013000-08	130.00	2.50	OR60013800-08	138.00	6.00
OR30012450-08	124.50	3.00	OR20013000-08	130.00	2.00	OR40013800-08	138.00	4.00
OR57012460-10	124.60	5.70	OR70013000-08	130.00	7.00	OR20013800-08	138.00	2.00
OR30012500-08	125.00	3.00	OR55013000-08	130.00	5.50	OR50013800-08	138.00	5.00
OR50012500-08	125.00	5.00	OR50013000-08	130.00	5.00	OR35013800-08	138.00	3.50
OR60012500-08	125.00	6.00	OR60013000-08	130.00	6.00	OR30013800-08	138.00	3.00
OR70012500-08	125.00	7.00	OR35013000-08	130.00	3.50	OR35013900-10	139.00	3.50
OR40012500-08	125.00	4.00	OR30013200-08	132.00	3.00	OR53313907-08	139.07	5.33
OR12312500-10	125.00	12.30	OR40013200-08	132.00	4.00	OR69913907-08	139.07	6.99
OR25012500-08	125.00	2.50	OR60013200-08	132.00	6.00	OR35313929-10	139.29	3.53
OR35012500-08	125.00	3.50	OR35313200-10	132.00	3.53	OR35313929-08	139.29	3.53
OR20012500-08	125.00	2.00	OR50013200-08	132.00	5.00	OR57013930-08	139.30	5.70
OR69912637-08	126.37	6.99	OR26213270-10	132.70	2.62	OR26213937-08	139.37	2.62
OR53312637-08	126.37	5.33	OR69913272-08	132.72	6.99	OR31013940-10	139.40	3.10
OR35312659-08	126.59	3.53	OR53313272-08	132.72	5.33	OR57013960-10	139.60	5.70
OR35312659-10	126.59	3.53	OR35313294-08	132.94	3.53	OR35014000-08	140.00	3.50
OR26212667-08	126.67	2.62	OR30013300-08	133.00	3.00	OR55014000-08	140.00	5.50
OR17812672-08	126.72	1.78	OR26213302-08	133.02	2.62	OR40014000-08	140.00	4.00
OR40012700-08	127.00	4.00	OR17813307-08	133.07	1.78	OR70014000-08	140.00	7.00
OR25012700-08	127.00	2.50	OR40013400-08	134.00	4.00	OR25014000-08	140.00	2.50
OR50012700-08	127.00	5.00	OR57013430-08	134.30	5.70	OR60014000-08	140.00	6.00
OR35012700-08	127.00	3.50	OR31013440-10	134.40	3.10	OR20014000-08	140.00	2.00
OR30012800-08	128.00	3.00	OR30013450-08	134.50	3.00	OR30014000-08	140.00	3.00
OR60012800-08	128.00	6.00	OR36013480-10	134.80	3.60	OR50014000-08	140.00	5.00
OR45012800-08	128.00	4.50	OR35313500-08	135.00	3.53	OR35314173-10	141.73	3.53
OR20012800-08	128.00	2.00	OR60013500-08	135.00	6.00	OR40014200-08	142.00	4.00
OR50012800-08	128.00	5.00	OR40013500-08	135.00	4.00	OR30014200-08	142.00	3.00

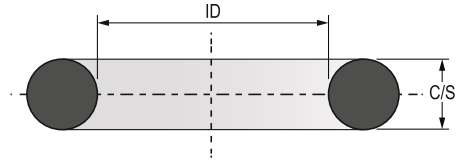
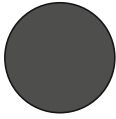

Max Spare Part No.	ID (mm)	C/S (mm)	Max Spare Part No.	ID (mm)	C/S (mm)	Max Spare Part No.	ID (mm)	C/S (mm)
OR50014200-08	142.00	5.00	OR35314882-10	148.82	3.53	OR40015500-08	155.00	4.00
OR20014200-08	142.00	2.00	OR35314882-08	148.82	3.53	OR26215576-08	155.76	2.62
OR25014200-08	142.00	2.50	OR57014920-10	149.20	5.70	OR20015600-08	156.00	2.00
OR53314224-08	142.24	5.33	OR57014920-08	149.20	5.70	OR35015600-08	156.00	3.50
OR69914224-08	142.24	6.99	OR35314930-10	149.30	3.53	OR35315694-10	156.94	3.53
OR35314247-08	142.47	3.53	OR31014940-10	149.40	3.10	OR15015700-08	157.00	1.50
OR35314247-10	142.47	3.53	OR60015000-08	150.00	6.00	OR50015800-08	158.00	5.00
OR35014300-08	143.00	3.50	OR35015000-10	150.00	3.50	OR69915812-08	158.12	6.99
OR30014300-08	143.00	3.00	OR35015000-08	150.00	3.50	OR53315812-08	158.12	5.33
OR36014350-10	143.50	3.60	OR10015000-10	150.00	10.00	OR35315834-10	158.34	3.53
OR35014400-10	144.00	3.50	OR80015000-08	150.00	8.00	OR35315834-08	158.34	3.53
OR57014430-10	144.30	5.70	OR50015000-08	150.00	5.00	OR26215842-08	158.42	2.62
OR57014430-08	144.30	5.70	OR25015000-08	150.00	2.50	OR57015930-08	159.30	5.70
OR31014440-10	144.40	3.10	OR20015000-08	150.00	2.00	OR30016000-08	160.00	3.00
OR20014500-08	145.00	2.00	OR30015000-08	150.00	3.00	OR35016000-08	160.00	3.50
OR25014500-08	145.00	2.50	OR70015000-08	150.00	7.00	OR60016000-08	160.00	6.00
OR55014500-08	145.00	5.50	OR55015000-08	150.00	5.50	OR20016000-08	160.00	2.00
OR35014500-10	145.00	3.50	OR40015000-08	150.00	4.00	OR70016000-08	160.00	7.00
OR50014500-08	145.00	5.00	OR50015100-08	151.00	5.00	OR40016000-08	160.00	4.00
OR40014500-08	145.00	4.00	OR53315177-08	151.77	5.33	OR53016000-08	160.00	5.30
OR30014500-08	145.00	3.00	OR69915177-08	151.77	6.99	OR55016000-08	160.00	5.50
OR53314542-08	145.42	5.33	OR35315199-10	151.99	3.53	OR25016000-08	160.00	2.50
OR69914542-08	145.42	6.99	OR35315199-08	151.99	3.53	OR50016000-08	160.00	5.00
OR35314564-10	145.64	3.53	OR40015200-08	152.00	4.00	OR70016100-08	161.00	7.00
OR35314564-08	145.64	3.53	OR30015200-08	152.00	3.00	OR20016200-08	162.00	2.00
OR26214572-10	145.72	2.62	OR20015200-08	152.00	2.00	OR40016200-08	162.00	4.00
OR26214572-08	145.72	2.62	OR26215207-08	152.07	2.62	OR30016200-08	162.00	3.00
OR50014700-08	147.00	5.00	OR30015400-08	154.00	3.00	OR70016200-08	162.00	7.00
OR35014700-08	147.00	3.50	OR40015400-08	154.00	4.00	OR57016260-10	162.60	5.70
OR30014800-08	148.00	3.00	OR35015400-08	154.00	3.50	OR35016300-08	163.00	3.50
OR35014800-10	148.00	3.50	OR57015430-08	154.30	5.70	OR35016300-10	163.00	3.50
OR40014800-08	148.00	4.00	OR70015500-08	155.00	7.00	OR35016386-10	163.86	3.50
OR35014800-08	148.00	3.50	OR50015500-08	155.00	5.00	OR40016400-08	164.00	4.00
OR60014800-08	148.00	6.00	OR25015500-08	155.00	2.50	OR60016400-08	164.00	6.00
OR69914859-08	148.59	6.99	OR20015500-08	155.00	2.00	OR30016400-08	164.00	3.00
OR53314859-10	148.59	5.33	OR30015500-08	155.00	3.00	OR57016420-10	164.20	5.70
OR53314859-08	148.59	5.33	OR55015500-08	155.00	5.50	OR57016420-08	164.20	5.70

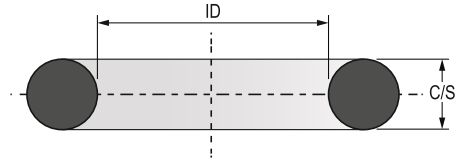
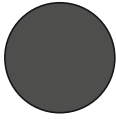

Max Spare Part No.	ID (mm)	C/S (mm)	Max Spare Part No.	ID (mm)	C/S (mm)	Max Spare Part No.	ID (mm)	C/S (mm)
OR57016430-10	164.30	5.70	OR30017400-08	174.00	3.00	OR26218382-08	183.82	2.62
OR31016430-10	164.30	3.10	OR84017450-08	174.50	8.40	OR60018400-08	184.00	6.00
OR53316447-10	164.47	5.33	OR50017500-08	175.00	5.00	OR57018430-10	184.30	5.70
OR53316447-08	164.47	5.33	OR35017500-10	175.00	3.50	OR57018430-08	184.30	5.70
OR69916447-08	164.47	6.99	OR20017500-08	175.00	2.00	OR20018500-08	185.00	2.00
OR84016450-08	164.50	8.40	OR30017500-08	175.00	3.00	OR40018500-08	185.00	4.00
OR30016450-08	164.50	3.00	OR40017500-08	175.00	4.00	OR35018500-08	185.00	3.50
OR35316469-10	164.69	3.53	OR25017500-08	175.00	2.50	OR30018500-08	185.00	3.00
OR35316469-08	164.69	3.53	OR35017626-10	176.26	3.50	OR50018500-08	185.00	5.00
OR26216477-08	164.77	2.62	OR69917717-08	177.17	6.99	OR30018700-08	187.00	3.00
OR20016500-08	165.00	2.00	OR53317717-08	177.17	5.33	OR30018700-10	187.00	3.00
OR60016500-08	165.00	6.00	OR35317739-10	177.39	3.53	OR60018800-08	188.00	6.00
OR50016500-08	165.00	5.00	OR35317739-08	177.39	3.53	OR35018800-10	188.00	3.50
OR60016800-08	168.00	6.00	OR26217747-08	177.47	2.62	OR35018800-08	188.00	3.50
OR57016800-10	168.00	5.70	OR30017800-08	178.00	3.00	OR35018850-10	188.50	3.50
OR40016800-08	168.00	4.00	OR35017800-10	178.00	3.50	OR35318924-10	189.24	3.53
OR30016900-08	169.00	3.00	OR30017900-08	179.00	3.00	OR57018930-10	189.30	5.70
OR57016930-10	169.30	5.70	OR57017930-10	179.30	5.70	OR57018930-08	189.30	5.70
OR57016930-08	169.30	5.70	OR31017930-10	179.30	3.10	OR53318987-08	189.87	5.33
OR50017000-08	170.00	5.00	OR57017930-08	179.30	5.70	OR69918987-08	189.87	6.99
OR40017000-08	170.00	4.00	OR60018000-08	180.00	6.00	OR40019000-08	190.00	4.00
OR35317000-10	170.00	3.53	OR40018000-08	180.00	4.00	OR50019000-08	190.00	5.00
OR20017000-08	170.00	2.00	OR20018000-08	180.00	2.00	OR30019000-11	190.00	3.00
OR25017000-08	170.00	2.50	OR25018000-08	180.00	2.50	OR55019000-08	190.00	5.50
OR60017000-08	170.00	6.00	OR50018000-08	180.00	5.00	OR15019000-10	190.00	1.50
OR55017000-08	170.00	5.50	OR35018000-08	180.00	3.50	OR60019000-08	190.00	6.00
OR30017000-08	170.00	3.00	OR30018000-08	180.00	3.00	OR70019000-08	190.00	7.00
OR53317082-08	170.82	5.33	OR70018000-08	180.00	7.00	OR30019000-08	190.00	3.00
OR69917082-08	170.82	6.99	OR25018200-08	182.00	2.50	OR35319009-10	190.09	3.53
OR35317104-10	171.04	3.53	OR70018200-08	182.00	7.00	OR35319009-08	190.09	3.53
OR35317104-08	171.04	3.53	OR30018200-08	182.00	3.00	OR26219017-08	190.17	2.62
OR26217112-08	171.12	2.62	OR30018300-08	183.00	3.00	OR40019200-08	192.00	4.00
OR40017200-08	172.00	4.00	OR69918352-08	183.52	6.99	OR30019200-08	192.00	3.00
OR50017200-08	172.00	5.00	OR53318352-08	183.52	5.33	OR50019200-08	192.00	5.00
OR30017200-08	172.00	3.00	OR32018360-10	183.60	3.20	OR35019300-08	193.00	3.50
OR30017400-10	174.00	3.00	OR35318374-10	183.74	3.53	OR40019400-08	194.00	4.00
OR35017400-08	174.00	3.50	OR35318374-08	183.74	3.53	OR35319400-10	194.00	3.53

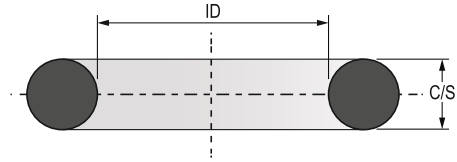
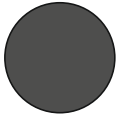

Max Spare Part No.	ID (mm)	C/S (mm)	Max Spare Part No.	ID (mm)	C/S (mm)	Max Spare Part No.	ID (mm)	C/S (mm)
OR25019400-08	194.00	2.50	OR26220922-08	209.22	2.62	OR700022700-10	227.00	7.00
OR31019430-10	194.30	3.10	OR57020930-08	209.30	5.70	OR53322797-08	227.97	5.33
OR57019430-10	194.30	5.70	OR31020930-10	209.30	3.10	OR69922797-08	227.97	6.99
OR57019430-08	194.30	5.70	OR20021000-08	210.00	2.00	OR35322819-08	228.19	3.53
OR30019500-08	195.00	3.00	OR60021000-08	210.00	6.00	OR26222827-08	228.27	2.62
OR50019500-08	195.00	5.00	OR50021000-08	210.00	5.00	OR57022930-10	229.30	5.70
OR53319622-08	196.22	5.33	OR55021000-08	210.00	5.50	OR57022930-08	229.30	5.70
OR69919622-08	196.22	6.99	OR40021000-08	210.00	4.00	OR50023000-08	230.00	5.00
OR10319640-10	196.40	10.30	OR30021000-08	210.00	3.00	OR40023000-08	230.00	4.00
OR35319644-10	196.44	3.53	OR30021200-08	212.00	3.00	OR25023000-08	230.00	2.50
OR35319644-08	196.44	3.53	OR40021200-10	212.00	4.00	OR30023000-08	230.00	3.00
OR26219652-08	196.52	2.62	OR57021250-10	212.50	5.70	OR40023200-10	232.00	4.00
OR57019920-10	199.20	5.70	OR50021500-08	215.00	5.00	OR30023300-08	233.00	3.00
OR57019920-08	199.20	5.70	OR30021500-08	215.00	3.00	OR50023400-08	234.00	5.00
OR57019930-10	199.30	5.70	OR60021500-08	215.00	6.00	OR53323432-08	234.32	5.33
OR30020000-08	200.00	3.00	OR69921527-08	215.27	6.99	OR35323454-08	234.54	3.53
OR25020000-08	200.00	2.50	OR53321527-08	215.27	5.33	OR30023500-08	235.00	3.00
OR20020000-08	200.00	2.00	OR35321549-10	215.49	3.53	OR70023600-08	236.00	7.00
OR35020000-08	200.00	3.50	OR35321549-08	215.49	3.53	OR35023800-10	238.00	3.50
OR70020000-08	200.00	7.00	OR26221557-08	215.57	2.62	OR57023930-08	239.30	5.70
OR40020000-08	200.00	4.00	OR60021800-08	218.00	6.00	OR60024000-08	240.00	6.00
OR50020000-08	200.00	5.00	OR53021800-08	218.00	5.30	OR40024000-08	240.00	4.00
OR60020000-08	200.00	6.00	OR40021800-08	218.00	4.00	OR50024000-08	240.00	5.00
OR20020200-08	202.00	2.00	OR57021930-10	219.30	5.70	OR30024000-08	240.00	3.00
OR30020200-08	202.00	3.00	OR57021930-08	219.30	5.70	OR69924067-08	240.67	6.99
OR69920257-08	202.57	6.99	OR35321949-10	219.49	3.53	OR53324067-08	240.67	5.33
OR53320257-08	202.57	5.33	OR40022000-08	220.00	4.00	OR35324089-08	240.89	3.53
OR35320279-10	202.79	3.53	OR80022000-08	220.00	8.00	OR30024500-08	245.00	3.00
OR35320279-08	202.79	3.53	OR30022000-08	220.00	3.00	OR50024500-08	245.00	5.00
OR26220287-08	202.87	2.62	OR60022000-08	220.00	6.00	OR60024700-08	247.00	6.00
OR57020360-10	203.60	5.70	OR50022000-08	220.00	5.00	OR53324702-08	247.02	5.33
OR60020500-08	205.00	6.00	OR53322162-08	221.62	5.33	OR35324724-08	247.24	3.53
OR40020500-08	205.00	4.00	OR35322184-08	221.84	3.53	OR26224732-08	247.32	2.62
OR50020500-08	205.00	5.00	OR57022430-10	224.30	5.70	OR57024930-08	249.30	5.70
OR30020500-08	205.00	3.00	OR40022500-08	225.00	4.00	OR84024950-08	249.50	8.40
OR53320892-08	208.92	5.33	OR50022500-08	225.00	5.00	OR35025000-08	250.00	3.50
OR35320914-08	209.14	3.53	OR30022500-08	225.00	3.00	OR30025000-08	250.00	3.00

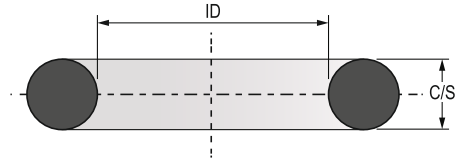
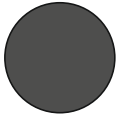

Max Spare Part No.	ID (mm)	C/S (mm)	Max Spare Part No.	ID (mm)	C/S (mm)	Max Spare Part No.	ID (mm)	C/S (mm)
OR60025000-08	250.00	6.00	OR30028500-08	285.00	3.00	OR50033500-08	335.00	5.00
OR40025000-08	250.00	4.00	OR57028930-08	289.30	5.70	OR57033930-08	339.30	5.70
OR70025000-08	250.00	7.00	OR60029000-08	290.00	6.00	OR84033950-08	339.50	8.40
OR50025000-08	250.00	5.00	OR50029000-08	290.00	5.00	OR50034000-08	340.00	5.00
OR35325200-10	252.00	3.53	OR30029000-08	290.00	3.00	OR70034000-08	340.00	7.00
OR69925337-08	253.37	6.99	OR53329147-08	291.47	5.33	OR69934227-08	342.27	6.99
OR35325359-08	253.59	3.53	OR70029150-08	291.50	7.00	OR50035000-08	350.00	5.00
OR31025420-10	254.20	3.10	OR35329169-08	291.69	3.53	OR60035000-08	350.00	6.00
OR57025930-08	259.30	5.70	OR60029500-08	295.00	6.00	OR84035450-08	354.50	8.40
OR30026000-08	260.00	3.00	OR57029930-08	299.30	5.70	OR69935497-08	354.97	6.99
OR40026000-08	260.00	4.00	OR80030000-08	300.00	8.00	OR53335497-08	354.97	5.33
OR25026000-08	260.00	2.50	OR30030000-08	300.00	3.00	OR35335519-08	355.19	3.53
OR50026000-08	260.00	5.00	OR50030000-08	300.00	5.00	OR57035930-08	359.30	5.70
OR50026500-08	265.00	5.00	OR60030000-08	300.00	6.00	OR84035950-08	359.50	8.40
OR40026500-08	265.00	4.00	OR70030417-08	304.17	7.00	OR50036500-08	365.00	5.00
OR70026500-08	265.00	7.00	OR53330417-08	304.17	5.33	OR50037000-08	370.00	5.00
OR53326607-08	266.07	5.33	OR35330439-08	304.39	3.53	OR57037930-08	379.30	5.70
OR69926607-08	266.07	6.99	OR50030500-08	305.00	5.00	OR40038000-08	380.00	4.00
OR35326629-08	266.29	3.53	OR70030500-08	305.00	7.00	OR53338037-08	380.37	5.33
OR57026930-08	269.30	5.70	OR57030930-08	309.30	5.70	OR35338059-08	380.59	3.53
OR30027000-08	270.00	3.00	OR30031000-08	310.00	3.00	OR40038700-08	387.00	4.00
OR60027000-08	270.00	6.00	OR50031000-08	310.00	5.00	OR30039000-08	390.00	3.00
OR40027000-08	270.00	4.00	OR60031000-08	310.00	6.00	OR69939307-08	393.07	6.99
OR50027000-08	270.00	5.00	OR60031500-08	315.00	6.00	OR69940526-08	405.26	6.99
OR35327200-08	272.00	3.53	OR50031500-08	315.00	5.00	OR35340526-08	405.26	3.53
OR50027500-08	275.00	5.00	OR69931687-08	316.87	6.99	OR53340526-08	405.26	5.33
OR69927877-08	278.77	6.99	OR57031930-08	319.30	5.70	OR69941796-08	417.96	6.99
OR53327877-08	278.77	5.33	OR30032000-06	320.00	3.00	OR57041930-08	419.30	5.70
OR35327899-08	278.99	3.53	OR70032000-08	320.00	7.00	OR50042000-08	420.00	5.00
OR57027930-08	279.30	5.70	OR69932957-08	329.57	6.99	OR80042500-08	425.00	8.00
OR60028000-08	280.00	6.00	OR53332957-08	329.57	5.33	OR50043000-08	430.00	5.00
OR30028000-08	280.00	3.00	OR35332979-10	329.79	3.53	OR70043000-08	430.00	7.00
OR50028000-08	280.00	5.00	OR35332979-08	329.79	3.53	OR50044000-08	440.00	5.00
OR70028000-08	280.00	7.00	OR40033000-08	330.00	4.00	OR69945600-08	456.00	6.99
OR40028500-08	285.00	4.00	OR50033000-08	330.00	5.00	OR50049000-08	490.00	5.00
OR70028500-08	285.00	7.00	OR84033450-08	334.50	8.40	OR70050000-08	500.00	7.00

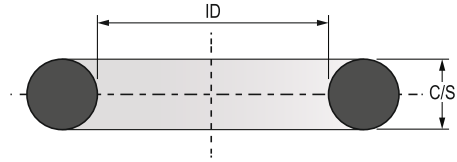
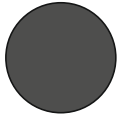

**MATERIAL:** FKM (Viton®) 70 75 Shore 'A'

**MAX OPERATING CONDITIONS :**

Temp. -40°C to +220°C      Pressure 160 BAR

Ordering Information (Dimensions in mm)

IS : 9975 - Dimension Tolerance

Max Spare Part No.	ID (mm)	C/S (mm)	Max Spare Part No.	ID (mm)	C/S (mm)	Max Spare Part No.	ID (mm)	C/S (mm)
OR15200142-64	1.42	1.52	OR15000550-64	5.50	1.50	OR25000800-64	8.00	2.50
OR17800168-66	1.68	1.78	OR24000560-64	5.60	2.40	OR22000800-64	8.00	2.20
OR10000200-64	2.00	1.00	OR35300594-64	5.94	3.53	OR30000800-64	8.00	3.00
OR15000200-64	2.00	1.50	OR20000600-64	6.00	2.00	OR18000800-64	8.00	1.80
OR17800257-64	2.57	1.78	OR30000600-64	6.00	3.00	OR10000800-64	8.00	1.00
OR16000270-64	2.70	1.60	OR25000600-64	6.00	2.50	OR20000800-66	8.00	2.00
OR17800290-64	2.90	1.78	OR10000600-64	6.00	1.00	OR15000800-64	8.00	1.50
OR10000300-64	3.00	1.00	OR15000600-64	6.00	1.50	OR24000830-64	8.30	2.40
OR15000300-64	3.00	1.50	OR26200602-64	6.02	2.62	OR15000840-64	8.40	1.50
OR20000300-64	3.00	2.00	OR17800607-64	6.07	1.78	OR18000840-64	8.40	1.80
OR16000320-64	3.20	1.60	OR20000650-64	6.50	2.00	OR20000850-64	8.50	2.00
OR15000350-64	3.50	1.50	OR15000650-64	6.50	1.50	OR17800873-64	8.73	1.78
OR17800368-64	3.68	1.78	OR18000650-64	6.50	1.80	OR19000880-64	8.80	1.90
OR18000400-64	4.00	1.80	OR17800675-64	6.75	1.78	OR40000900-64	9.00	4.00
OR25000400-64	4.00	2.50	OR15000700-64	7.00	1.50	OR30000900-64	9.00	3.00
OR10000400-64	4.00	1.00	OR20000700-64	7.00	2.00	OR18000900-64	9.00	1.80
OR15000400-64	4.00	1.50	OR25000700-64	7.00	2.50	OR15000900-64	9.00	1.50
OR20000400-64	4.00	2.00	OR10000700-64	7.00	1.00	OR10000900-64	9.00	1.00
OR15000430-64	4.30	1.50	OR17000700-64	7.00	1.70	OR16000900-64	9.00	1.60
OR35300434-64	4.34	3.53	OR18000740-64	7.40	1.80	OR20000900-64	9.00	2.00
OR17800447-64	4.47	1.78	OR25000750-64	7.50	2.50	OR25000900-64	9.00	2.50
OR15000450-64	4.50	1.50	OR10000750-64	7.50	1.00	OR35300912-66	9.12	3.53
OR20000450-64	4.50	2.00	OR20000750-64	7.50	2.00	OR35300912-64	9.12	3.53
OR20000500-64	5.00	2.00	OR15000750-64	7.50	1.50	OR26200919-64	9.19	2.62
OR25000500-64	5.00	2.50	OR15000750-67	7.50	1.50	OR17800925-64	9.25	1.78
OR10000500-64	5.00	1.00	OR35300752-64	7.52	3.53	OR17800925-66	9.25	1.78
OR13000500-64	5.00	1.30	OR26200759-64	7.59	2.62	OR24000930-64	9.30	2.40
OR17800500-64	5.00	1.78	OR17800765-64	7.65	1.78	OR25000950-64	9.50	2.50
OR15000500-64	5.00	1.50	OR16300765-64	7.65	1.63	OR20000950-64	9.50	2.00
OR17800528-64	5.28	1.78	OR20000800-64	8.00	2.00	OR18000950-64	9.50	1.80

\* BL stands for Black Colour O-Rings  
Other O-Rings are available in Brown Colour

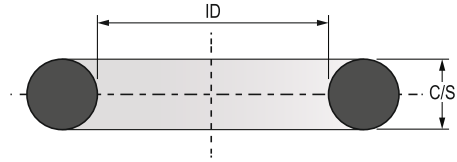
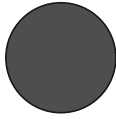

Max Spare Part No.	ID (mm)	C/S (mm)	Max Spare Part No.	ID (mm)	C/S (mm)	Max Spare Part No.	ID (mm)	C/S (mm)
OR15000950-64	9.50	1.50	OR10001200-64	12.00	1.00	OR30001450-64	14.50	3.00
OR15000980-64	9.80	1.50	OR35001200-64	12.00	3.50	OR20001500-64	15.00	2.00
OR19000980-64	9.80	1.90	OR30001200-64	12.00	3.00	OR30001500-64	15.00	3.00
OR18001000-64	10.00	1.80	OR25001200-64	12.00	2.50	OR35001500-64	15.00	3.50
OR20001000-64	10.00	2.00	OR20001200-66	12.00	2.00	OR18001500-64	15.00	1.80
OR22001000-64	10.00	2.20	OR53301207-64	12.07	5.33	OR50001500-64	15.00	5.00
OR16001000-64	10.00	1.60	OR16001210-64	12.10	1.60	OR15001500-64	15.00	1.50
OR20001000-67	10.00	2.00	OR35301229-64	12.29	3.53	OR25001500-64	15.00	2.50
OR30001000-64	10.00	3.00	OR24001230-64	12.30	2.40	OR20001500-66	15.00	2.00
OR15001000-64	10.00	1.50	OR26201237-64	12.37	2.62	OR26201508-64	15.08	2.62
OR20001000-66	10.00	2.00	OR17801242-64	12.42	1.78	OR53301524-64	15.24	5.33
OR25001000-64	10.00	2.50	OR25001250-64	12.50	2.50	OR24001530-64	15.30	2.40
OR53301046-64	10.46	5.33	OR20001250-64	12.50	2.00	OR35301547-64	15.47	3.53
OR25001050-64	10.50	2.50	OR15001250-64	12.50	1.50	OR25001550-64	15.50	2.50
OR15001050-64	10.50	1.50	OR25001300-64	13.00	2.50	OR20001550-64	15.50	2.00
OR20001050-64	10.50	2.00	OR30001300-64	13.00	3.00	OR26201554-66	15.54	2.62
OR18001060-64	10.60	1.80	OR15001300-64	13.00	1.50	OR26201554-64	15.54	2.62
OR35301069-64	10.69	3.53	OR18001300-64	13.00	1.80	OR17801560-64	15.60	1.78
OR26201077-64	10.77	2.62	OR20001300-64	13.00	2.00	OR20001600-64	16.00	2.00
OR17801082-64	10.82	1.78	OR26201310-64	13.10	2.62	OR30001600-64	16.00	3.00
OR15001100-64	11.00	1.50	OR25001350-64	13.50	2.50	OR16001600-64	16.00	1.60
OR25001100-64	11.00	2.50	OR20001350-64	13.50	2.00	OR26501600-64	16.00	2.65
OR30001100-64	11.00	3.00	OR53301364-64	13.64	5.33	OR22001600-64	16.00	2.20
OR10001100-64	11.00	1.00	OR35301387-64	13.87	3.53	OR15001600-64	16.00	1.50
OR20001150-64	11.00	2.00	OR26201394-64	13.94	2.62	OR17801600-64	16.00	1.78
OR17801111-64	11.11	1.78	OR17801400-66	14.00	1.78	OR40001600-64	16.00	4.00
OR24001130-64	11.30	2.40	OR40001400-64	14.00	4.00	OR25001600-64	16.00	2.50
OR30001150-64	11.50	3.00	OR15001400-64	14.00	1.50	OR24001630-67	16.30	2.40
OR25001150-64	11.50	2.50	OR24001400-64	14.00	2.40	OR25001650-64	16.50	2.50
OR15001150-64	11.50	1.50	OR30001400-64	14.00	3.00	OR20001650-64	16.50	2.00
OR20001150-64	11.50	2.00	OR17801400-64	14.00	1.78	OR53301681-64	16.81	5.33
OR20001180-64	11.80	2.00	OR20001400-64	14.00	2.00	OR30001700-64	17.00	3.00
OR26201191-64	11.91	2.62	OR25001400-66	14.00	2.50	OR25001700-64	17.00	2.50
OR15001200-64	12.00	1.50	OR30001400-66	14.00	3.00	OR20001700-64	17.00	2.00
OR20001200-64	12.00	2.00	OR25001400-64	14.00	2.50	OR15001700-64	17.00	1.50
OR20001200-67	12.00	2.00	OR20001450-64	14.50	2.00	OR35301704-64	17.04	3.53
OR18001200-64	12.00	1.80	OR25001450-64	14.50	2.50	OR26201712-66	17.12	2.62

\* BL stands for Black Colour O-Rings  
Other O-Rings are available in Brown Colour

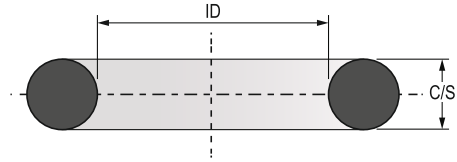
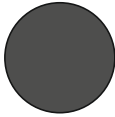

Max Spare Part No.	ID (mm)	C/S (mm)	Max Spare Part No.	ID (mm)	C/S (mm)	Max Spare Part No.	ID (mm)	C/S (mm)
OR26201712-64	17.12	2.62	OR26202029-66	20.29	2.62	OR17802352-66	23.52	1.78
OR17801717-64	17.17	1.78	OR26202029-64	20.29	2.62	OR17802352-64	23.52	1.78
OR24001730-64	17.30	2.40	OR24002030-64	20.30	2.40	OR15002400-64	24.00	1.50
OR20001750-64	17.50	2.00	OR24002030-67	20.30	2.40	OR20002400-64	24.00	2.00
OR17801760-64	17.60	1.78	OR17802035-64	20.35	1.78	OR25002400-64	24.00	2.50
OR25001800-64	18.00	2.50	OR26202063-64	20.63	2.62	OR35002400-64	24.00	3.50
OR30001800-64	18.00	3.00	OR25002100-64	21.00	2.50	OR30002400-64	24.00	3.00
OR35001800-64	18.00	3.50	OR15002100-64	21.00	1.50	OR31002440-64	24.40	3.10
OR10001800-64	18.00	1.00	OR20002100-64	21.00	2.00	OR40002450-64	24.50	4.00
OR50001800-64	18.00	5.00	OR30002100-64	21.00	3.00	OR20002450-64	24.50	2.00
OR20001800-64	18.00	2.00	OR24002130-64	21.30	2.40	OR53302477-64	24.77	5.33
OR15001800-64	18.00	1.50	OR25002150-64	21.50	2.50	OR35302499-64	24.99	3.53
OR53301842-64	18.42	5.33	OR20002150-64	21.50	2.00	OR35302499-67	24.99	3.53
OR35301864-64	18.64	3.53	OR53302159-64	21.59	5.33	OR25002500-64	25.00	2.50
OR35301864-66	18.64	3.53	OR35302182-64	21.82	3.53	OR30002500-64	25.00	3.00
OR26201872-64	18.72	2.62	OR26202189-66	21.89	2.62	OR40002500-64	25.00	4.00
OR17801877-66	18.77	1.78	OR26202189-64	21.89	2.62	OR15002500-64	25.00	1.50
OR17801877-64	18.77	1.78	OR17802195-66	21.95	1.78	OR20002500-64	25.00	2.00
OR15001900-64	19.00	1.50	OR17802195-64	21.95	1.78	OR50002500-64	25.00	5.00
OR25001900-64	19.00	2.50	OR30002200-64	22.00	3.00	OR26202507-64	25.07	2.62
OR35001900-64	19.00	3.50	OR15002200-64	22.00	1.50	OR17802512-64	25.12	1.78
OR30001900-64	19.00	3.00	OR40002200-64	22.00	4.00	OR24002530-64	25.30	2.40
OR20001900-64	19.00	2.00	OR25002200-64	22.00	2.50	OR24002530-67	25.30	2.40
OR40001900-64	19.00	4.00	OR22002200-64	22.00	2.20	OR20002550-64	25.50	2.00
OR25001950-64	19.50	2.50	OR50002200-64	22.00	5.00	OR20002600-64	26.00	2.00
OR20001950-64	19.50	2.00	OR20002200-64	22.00	2.00	OR25002600-64	26.00	2.50
OR53301999-64	19.99	5.33	OR20002250-64	22.50	2.00	OR30002600-66	26.00	3.00
OR18002000-64	20.00	1.80	OR30002300-64	23.00	3.00	OR15002600-64	26.00	1.50
OR25002000-64	20.00	2.50	OR35002300-64	23.00	3.50	OR30002600-64	26.00	3.00
OR35002000-64	20.00	3.50	OR25002300-64	23.00	2.50	OR35002600-64	26.00	3.50
OR50002000-64	20.00	5.00	OR15002300-64	23.00	1.50	OR53302634-64	26.34	5.33
OR15002000-64	20.00	1.50	OR20002300-64	23.00	2.00	OR20002650-64	26.50	2.00
OR20002000-64	20.00	2.00	OR53302316-64	23.16	5.33	OR35302657-64	26.57	3.53
OR20002000-66	20.00	2.00	OR35302339-64	23.39	3.53	OR26202664-64	26.64	2.62
OR30002000-64	20.00	3.00	OR26202347-64	23.47	2.62	OR17802670-64	26.70	1.78
OR40002000-64	20.00	4.00	OR26202347-66	23.47	2.62	OR30002700-64	27.00	3.00
OR35302022-64	20.22	3.53	OR20002350-64	23.50	2.00	OR40002700-64	27.00	4.00

\* BL stands for Black Colour O-Rings  
Other O-Rings are available in Brown Colour

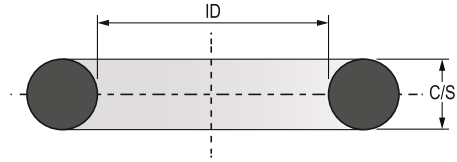
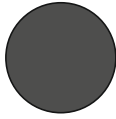

Max Spare Part No.	ID (mm)	C/S (mm)	Max Spare Part No.	ID (mm)	C/S (mm)	Max Spare Part No.	ID (mm)	C/S (mm)
OR15002700-64	27.00	1.50	OR30003000-64	30.00	3.00	OR30003400-64	34.00	3.00
OR25002700-64	27.00	2.50	OR35003000-64	30.00	3.50	OR53303429-64	34.29	5.33
OR20002700-64	27.00	2.00	OR50003000-64	30.00	5.00	OR35303452-64	34.52	3.53
OR35002700-64	27.00	3.50	OR40003000-64	30.00	4.00	OR26203459-64	34.59	2.62
OR24002730-64	27.30	2.40	OR15003000-64	30.00	1.50	OR17803465-64	34.65	1.78
OR25002750-64	27.50	2.50	OR25003000-64	30.00	2.50	OR30003500-64	35.00	3.00
OR20002750-64	27.50	2.00	OR20003000-64	30.00	2.00	OR25003500-64	35.00	2.50
OR24002760-64	27.60	2.40	OR35003100-64	31.00	3.50	OR40003500-64	35.00	4.00
OR53302794-64	27.94	5.33	OR20003100-64	31.00	2.00	OR15003500-64	35.00	1.50
OR30002800-64	28.00	3.00	OR25003100-64	31.00	2.50	OR20003500-64	35.00	2.00
OR40002800-64	28.00	4.00	OR30003100-64	31.00	3.00	OR35003500-64	35.00	3.50
OR20002800-64	28.00	2.00	OR53303112-64	31.12	5.33	OR50003500-64	35.00	5.00
OR15002800-64	28.00	1.50	OR35303134-64	31.34	3.53	OR30003550-64	35.50	3.00
OR25002800-64	28.00	2.50	OR26203142-64	31.42	2.62	OR50003600-64	36.00	5.00
OR32002800-64	28.00	3.20	OR17803147-64	31.47	1.78	OR40003600-64	36.00	4.00
OR35002800-64	28.00	3.50	OR15003200-64	32.00	1.50	OR35003600-64	36.00	3.50
OR50002800-64	28.00	5.00	OR25003200-64	32.00	2.50	OR25003600-64	36.00	2.50
OR35302817-64	28.17	3.53	OR20003200-64	32.00	2.00	OR30003600-64	36.00	3.00
OR26202824-64	28.24	2.62	OR30003200-64	32.00	3.00	OR20003600-64	36.00	2.00
OR17802830-64	28.30	1.78	OR35003200-64	32.00	3.50	OR35303609-64	36.09	3.53
OR17802830-66	28.30	1.78	OR40003200-64	32.00	4.00	OR26203617-64	36.17	2.62
OR25002850-64	28.50	2.50	OR35003250-64	32.50	3.50	OR30003650-64	36.50	3.00
OR20002850-64	28.50	2.00	OR53303269-64	32.69	5.33	OR35003700-64	37.00	3.50
OR25002900-64	29.00	2.50	OR35303292-64	32.92	3.53	OR25003700-64	37.00	2.50
OR30002900-64	29.00	3.00	OR35303292-67	32.92	3.53	OR20003700-64	37.00	2.00
OR35002900-64	29.00	3.50	OR26203299-64	32.99	2.62	OR15003700-64	37.00	1.50
OR20002900-64	29.00	2.00	OR20003300-64	33.00	2.00	OR20003740-64	37.40	2.00
OR15002900-64	29.00	1.50	OR40003300-64	33.00	4.00	OR53303746-64	37.46	5.33
OR31002940-64	29.40	3.10	OR30003300-64	33.00	3.00	OR30003750-64	37.50	3.00
OR20002950-64	29.50	2.00	OR25003300-64	33.00	2.50	OR35303769-67	37.69	3.53
OR30002950-64	29.50	3.00	OR17803305-64	33.05	1.78	OR35303769-64	37.69	3.53
OR53302951-64	29.51	5.33	OR24003330-67	33.30	2.40	OR26203777-64	37.77	2.62
OR24002960-64	29.60	2.40	OR24003330-64	33.30	2.40	OR17803782-64	37.82	1.78
OR35302974-64	29.74	3.53	OR24003330-66	33.30	2.40	OR40003800-64	38.00	4.00
OR26202982-64	29.82	2.62	OR20003400-64	34.00	2.00	OR15003800-64	38.00	1.50
OR17802987-64	29.87	1.78	OR25003400-64	34.00	2.50	OR30003800-64	38.00	3.00
OR26503000-64	30.00	2.65	OR35003400-64	34.00	3.50	OR50003800-64	38.00	5.00

\* BL stands for Black Colour O-Rings  
Other O-Rings are available in Brown Colour

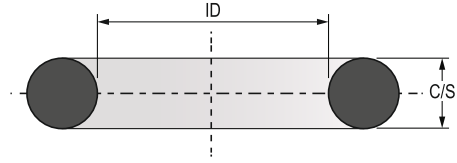
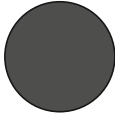

Max Spare Part No.	ID (mm)	C/S (mm)	Max Spare Part No.	ID (mm)	C/S (mm)	Max Spare Part No.	ID (mm)	C/S (mm)
OR20003800-64	38.00	2.00	OR35004400-64	44.00	3.50	OR20004800-64	48.00	2.00
OR35003800-64	38.00	3.50	OR40004400-64	44.00	4.00	OR26204890-64	48.90	2.62
OR25003800-64	38.00	2.50	OR25004400-64	44.00	2.50	OR35004900-64	49.00	3.50
OR35003900-64	39.00	3.50	OR20004400-64	44.00	2.00	OR20004900-64	49.00	2.00
OR30003900-64	39.00	3.00	OR35304404-64	44.04	3.53	OR30004900-64	49.00	3.00
OR25003900-64	39.00	2.50	OR26204412-64	44.12	2.62	OR25004900-64	49.00	2.50
OR20003900-64	39.00	2.00	OR17804417-64	44.17	1.78	OR30004950-64	49.50	3.00
OR26203934-64	39.34	2.62	OR31004440-64	44.40	3.10	OR35005000-64	50.00	3.50
OR30003950-64	39.50	3.00	OR35304450-64	44.50	3.53	OR20005000-64	50.00	2.00
OR35004000-64	40.00	3.50	OR20004480-64	44.80	2.00	OR40005000-64	50.00	4.00
OR20004000-64	40.00	2.00	OR30004500-64	45.00	3.00	OR25005000-64	50.00	2.50
OR30004000-64	40.00	3.00	OR25004500-64	45.00	2.50	OR30005000-64	50.00	3.00
OR15004000-64	40.00	1.50	OR40004500-64	45.00	4.00	OR50005000-64	50.00	5.00
OR40004000-64	40.00	4.00	OR35004500-64	45.00	3.50	OR53305017-64	50.17	5.33
OR25004000-64	40.00	2.50	OR20004500-64	45.00	2.00	OR35305039-64	50.39	3.53
OR50004000-64	40.00	5.00	OR50004500-64	45.00	5.00	OR26205047-64	50.47	2.62
OR53304064-64	40.64	5.33	OR26204569-64	45.69	2.62	OR17805052-64	50.52	1.78
OR35304087-64	40.87	3.53	OR20004600-64	46.00	2.00	OR20005100-64	51.00	2.00
OR26204094-64	40.94	2.62	OR25004600-64	46.00	2.50	OR25005100-64	51.00	2.50
OR25004100-64	41.00	2.50	OR40004600-64	46.00	4.00	OR30005100-64	51.00	3.00
OR17804100-64	41.00	1.78	OR35004600-64	46.00	3.50	OR35005100-64	51.00	3.50
OR20004100-64	41.00	2.00	OR30004600-64	46.00	3.00	OR40005200-64	52.00	4.00
OR30004150-64	41.50	3.00	OR53304699-64	46.99	5.33	OR20005200-64	52.00	2.00
OR40004200-64	42.00	4.00	OR30004700-64	47.00	3.00	OR30005200-64	52.00	3.00
OR30004200-64	42.00	3.00	OR25004700-64	47.00	2.50	OR26205207-64	52.07	2.62
OR35004200-64	42.00	3.50	OR20004700-64	47.00	2.00	OR40005300-64	53.00	4.00
OR50004200-64	42.00	5.00	OR35304722-64	47.22	3.53	OR15005300-64	53.00	1.50
OR25004200-64	42.00	2.50	OR35304722-67	47.22	3.53	OR25005300-64	53.00	2.50
OR20004200-64	42.00	2.00	OR35304722-66	47.22	3.53	OR20005300-64	53.00	2.00
OR30004220-64	42.20	3.00	OR26204729-64	47.29	2.62	OR35005300-64	53.00	3.50
OR26204252-64	42.52	2.62	OR17804735-64	47.35	1.78	OR53305334-64	53.34	5.33
OR35304294-64	42.94	3.53	OR25004800-64	48.00	2.50	OR35305357-66	53.57	3.53
OR30004300-64	43.00	3.00	OR30004800-64	48.00	3.00	OR35305357-64	53.57	3.53
OR25004300-64	43.00	2.50	OR40004800-64	48.00	4.00	OR26205364-64	53.64	2.62
OR20004300-64	43.00	2.00	OR60004800-64	48.00	6.00	OR17805370-64	53.70	1.78
OR53304382-64	43.82	5.33	OR35004800-64	48.00	3.50	OR40005400-64	54.00	4.00
OR30004400-64	44.00	3.00	OR50004800-64	48.00	5.00	OR30005400-64	54.00	3.00

\* BL stands for Black Colour O-Rings  
Other O-Rings are available in Brown Colour

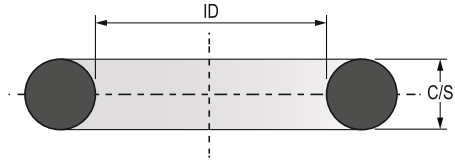

Max Spare Part No.	ID (mm)	C/S (mm)	Max Spare Part No.	ID (mm)	C/S (mm)	Max Spare Part No.	ID (mm)	C/S (mm)
OR20005400-64	54.00	2.00	OR31005940-64	59.40	3.10	OR30006500-64	65.00	3.00
OR30005500-64	55.00	3.00	OR53305969-64	59.69	5.33	OR30006600-64	66.00	3.00
OR55005500-64	55.00	5.50	OR35305992-64	59.92	3.53	OR20006600-64	66.00	2.00
OR40005500-64	55.00	4.00	OR26205999-64	59.99	2.62	OR25006600-64	66.00	2.50
OR25005500-64	55.00	2.50	OR60006000-64	60.00	6.00	OR53306604-64	66.04	5.33
OR20005500-64	55.00	2.00	OR50006000-64	60.00	5.00	OR35306627-64	66.27	3.53
OR50005500-64	55.00	5.00	OR35506000-64	60.00	3.55	OR26206634-64	66.34	2.62
OR35005500-64	55.00	3.50	OR20006000-64	60.00	2.00	OR17806640-64	66.40	1.78
OR26205525-64	55.25	2.62	OR40006000-64	60.00	4.00	OR35006700-64	67.00	3.50
OR35305556-64	55.56	3.53	OR30006000-64	60.00	3.00	OR20006700-64	67.00	2.00
OR30005600-64	56.00	3.00	OR17806005-64	60.05	1.78	OR40006700-64	67.00	4.00
OR50005600-64	56.00	5.00	OR20006100-64	61.00	2.00	OR30006700-64	67.00	3.00
OR25005600-64	56.00	2.50	OR30006100-64	61.00	3.00	OR26206795-64	67.95	2.62
OR40005600-64	56.00	4.00	OR50006100-64	61.00	5.00	OR20006800-64	68.00	2.00
OR20005600-64	56.00	2.00	OR26206160-64	61.60	2.62	OR30006800-64	68.00	3.00
OR35005600-64	56.00	3.50	OR30006200-64	62.00	3.00	OR50006800-64	68.00	5.00
OR53305652-64	56.52	5.33	OR35006200-64	62.00	3.50	OR40006800-64	68.00	4.00
OR35305674-67	56.74	3.53	OR40006200-64	62.00	4.00	OR35006800-64	68.00	3.50
OR35305674-64	56.74	3.53	OR20006200-64	62.00	2.00	OR30006900-64	69.00	3.00
OR26205682-64	56.82	2.62	OR53306287-64	62.87	5.33	OR35006900-64	69.00	3.50
OR17805687-64	56.87	1.78	OR30006300-64	63.00	3.00	OR20006900-64	69.00	2.00
OR35005700-64	57.00	3.50	OR20006300-64	63.00	2.00	OR57006920-64	69.20	5.70
OR30005700-64	57.00	3.00	OR40006300-64	63.00	4.00	OR53306922-64	69.22	5.33
OR25005700-64	57.00	2.50	OR35306309-64	63.09	3.53	OR35306944-64	69.44	3.53
OR20005700-64	57.00	2.00	OR26206317-64	63.17	2.62	OR35306944-67	69.44	3.53
OR50005700-64	57.00	5.00	OR17806322-64	63.22	1.78	OR26206952-64	69.52	2.62
OR20005800-64	58.00	2.00	OR30006400-64	64.00	3.00	OR17806957-64	69.57	1.78
OR30005800-64	58.00	3.00	OR35006400-64	64.00	3.50	OR40007000-64	70.00	4.00
OR35005800-64	58.00	3.50	OR20006400-64	64.00	2.00	OR50007000-64	70.00	5.00
OR25005800-64	58.00	2.50	OR31006440-64	64.40	3.10	OR20007000-64	70.00	2.00
OR40005800-64	58.00	4.00	OR30006450-64	64.50	3.00	OR35007000-64	70.00	3.50
OR26205842-64	58.42	2.62	OR26206477-64	64.77	2.62	OR30007000-64	70.00	3.00
OR35305874-64	58.74	3.53	OR35006500-64	65.00	3.50	OR20007100-64	71.00	2.00
OR30005900-64	59.00	3.00	OR20006500-64	65.00	2.00	OR26207112-64	71.12	2.62
OR35005900-64	59.00	3.50	OR25006500-64	65.00	2.50	OR40007200-64	72.00	4.00
OR20005900-64	59.00	2.00	OR40006500-64	65.00	4.00	OR50007200-64	72.00	5.00
OR57005920-64	59.20	5.70	OR50006500-64	65.00	5.00	OR20007200-64	72.00	2.00

\* BL stands for Black Colour O-Rings  
Other O-Rings are available in Brown Colour

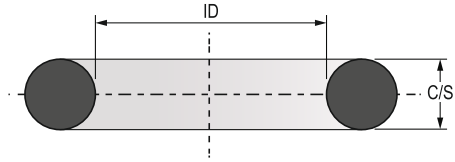
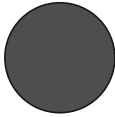

Max Spare Part No.	ID (mm)	C/S (mm)	Max Spare Part No.	ID (mm)	C/S (mm)	Max Spare Part No.	ID (mm)	C/S (mm)
OR35007200-64	72.00	3.50	OR35008000-64	80.00	3.50	OR25009000-64	90.00	2.50
OR30007200-64	72.00	3.00	OR50008000-64	80.00	5.00	OR30009000-64	90.00	3.00
OR53307239-64	72.39	5.33	OR20008000-64	80.00	2.00	OR35009000-64	90.00	3.50
OR35307262-64	72.62	3.53	OR40008000-64	80.00	4.00	OR20009000-64	90.00	2.00
OR26207269-64	72.69	2.62	OR30008000-66	80.00	3.00	OR40009000-64	90.00	4.00
OR17807275-64	72.75	1.78	OR20008100-64	81.00	2.00	OR55009000-64	90.00	5.50
OR35007300-64	73.00	3.50	OR53308192-64	81.92	5.33	OR53309144-64	91.44	5.33
OR30007300-64	73.00	3.00	OR30008200-64	82.00	3.00	OR35309167-64C	91.67	3.53
OR20007300-64	73.00	2.00	OR40008200-64	82.00	4.00	OR35309167-64	91.67	3.53
OR30007400-64	74.00	3.00	OR35308214-64	82.14	3.53	OR40009200-64	92.00	4.00
OR50007400-64	74.00	5.00	OR26208222-64	82.22	2.62	OR30009200-64	92.00	3.00
OR35007400-64	74.00	3.50	OR17808227-64	82.27	1.78	OR40009300-64	93.00	4.00
OR40007400-64	74.00	4.00	OR30008300-64	83.00	3.00	OR35009300-64	93.00	3.50
OR40007500-64	75.00	4.00	OR35008300-64	83.00	3.50	OR30009400-64	94.00	3.00
OR30007500-64	75.00	3.00	OR50008400-64	84.00	5.00	OR20009400-64	94.00	2.00
OR25007500-64	75.00	2.50	OR30008400-64	84.00	3.00	OR40009400-64	94.00	4.00
OR50007500-64	75.00	5.00	OR30008450-64	84.50	3.00	OR53309462-64	94.62	5.33
OR20007500-64	75.00	2.00	OR30008500-64	85.00	3.00	OR35309484-64	94.84	3.53
OR53307557-64	75.57	5.33	OR50008500-64	85.00	5.00	OR26209492-64	94.92	2.62
OR35307579-64	75.79	3.53	OR20008500-64	85.00	2.00	OR50009500-64	95.00	5.00
OR26207587-64	75.87	2.62	OR40008500-64	85.00	4.00	OR55009500-64	95.00	5.50
OR17807592-64	75.92	1.78	OR53308509-64	85.09	5.33	OR40009500-64	95.00	4.00
OR30007600-64	76.00	3.00	OR35308532-67	85.32	3.53	OR30009500-64	95.00	3.00
OR20007600-64	76.00	2.00	OR35308532-64	85.32	3.53	OR35009600-64	96.00	3.50
OR35007700-64	77.00	3.50	OR30008600-64	86.00	3.00	OR30009600-64	96.00	3.00
OR30007700-64	77.00	3.00	OR20008600-64	86.00	2.00	OR50009700-64	97.00	5.00
OR30007800-64	78.00	3.00	OR35008700-64	87.00	3.50	OR53309779-64	97.79	5.33
OR26207800-66	78.00	2.62	OR30008700-64	87.00	3.00	OR30009800-64	98.00	3.00
OR40007800-64	78.00	4.00	OR30008800-64	88.00	3.00	OR35309802-64	98.02	3.53
OR20007800-64	78.00	2.00	OR20008800-64	88.00	2.00	OR30009900-64	99.00	3.00
OR35007800-64	78.00	3.50	OR53308827-64	88.27	5.33	OR30010000-64	100.00	3.00
OR15007800-64	78.00	1.50	OR35308849-64	88.49	3.53	OR40010000-64	100.00	4.00
OR53307874-64	78.74	5.33	OR26208857-64	88.57	2.62	OR50010000-64	100.00	5.00
OR35307897-64	78.97	3.53	OR17808862-64	88.62	1.78	OR60010000-64	100.00	6.00
OR57007930-64	79.30	5.70	OR50008900-64	89.00	5.00	OR35010000-64	100.00	3.50
OR30007950-64	79.50	3.00	OR30008900-64	89.00	3.00	OR25010000-64	100.00	2.50
OR30008000-64	80.00	3.00	OR50009000-64	90.00	5.00	OR53310097-64	100.97	5.33

\* BL stands for Black Colour O-Rings  
Other O-Rings are available in Brown Colour

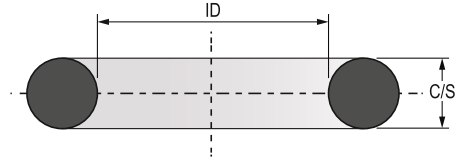

Max Spare Part No.	ID (mm)	C/S (mm)	Max Spare Part No.	ID (mm)	C/S (mm)	Max Spare Part No.	ID (mm)	C/S (mm)
OR35310119-64	101.19	3.53	OR30011500-64	115.00	3.00	OR25013000-64	130.00	2.50
OR26210127-64	101.27	2.62	OR40011500-64	115.00	4.00	OR30013000-64	130.00	3.00
OR17810132-64	101.32	1.78	OR53311684-64	116.84	5.33	OR20013200-64	132.00	2.00
OR30010200-64	102.00	3.00	OR69911684-64	116.84	6.99	OR69913272-64	132.72	6.99
OR50010200-64	102.00	5.00	OR35311707-64	117.07	3.53	OR53313272-64	132.72	5.33
OR40010200-64	102.00	4.00	OR50011800-64	118.00	5.00	OR35313294-64	132.94	3.53
OR30010400-64	104.00	3.00	OR30011800-64	118.00	3.00	OR26213302-64	133.02	2.62
OR53310414-64	104.14	5.33	OR35011800-64	118.00	3.50	OR30013450-64	134.50	3.00
OR57010420-64	104.20	5.70	OR57011930-64	119.30	5.70	OR50013500-64	135.00	5.00
OR35310437-64	104.37	3.53	OR20012000-64	120.00	2.00	OR53313589-64	135.89	5.33
OR50010500-64	105.00	5.00	OR50012000-64	120.00	5.00	OR69913589-64	135.89	6.99
OR55010500-64	105.00	5.50	OR40012000-64	120.00	4.00	OR35313612-64	136.12	3.53
OR40010500-64	105.00	4.00	OR30012000-64	120.00	3.00	OR53313907-64	139.07	5.33
OR20010500-64	105.00	2.00	OR69912002-64	120.02	6.99	OR35313929-64	139.29	3.53
OR30010500-64	105.00	3.00	OR53312002-64	120.02	5.33	OR26213937-64	139.37	2.62
OR53310732-64	107.32	5.33	OR35312024-64	120.24	3.53	OR70014000-64	140.00	7.00
OR35310754-64	107.54	3.53	OR26212032-64	120.32	2.62	OR60014000-64	140.00	6.00
OR26210762-64	107.62	2.62	OR40012200-64	122.00	4.00	OR50014000-64	140.00	5.00
OR30010800-64	108.00	3.00	OR53312319-64	123.19	5.33	OR40014000-64	140.00	4.00
OR40010800-64	108.00	4.00	OR69912319-64	123.19	6.99	OR30014000-64	140.00	3.00
OR57010960-64	109.60	5.70	OR35312342-64	123.42	3.53	OR40014200-64	142.00	4.00
OR50011000-64	110.00	5.00	OR30012500-64	125.00	3.00	OR53314224-64	142.24	5.33
OR60011000-64	110.00	6.00	OR35012500-64	125.00	3.50	OR69914224-64	142.24	6.99
OR30011000-64	110.00	3.00	OR50012500-64	125.00	5.00	OR35314247-64	142.47	3.53
OR40011000-64	110.00	4.00	OR69912637-64	126.37	6.99	OR70014400-64	144.00	7.00
OR35011000-64	110.00	3.50	OR53312637-64	126.37	5.33	OR30014500-64	145.00	3.00
OR20011000-64	110.00	2.00	OR35312659-64	126.59	3.53	OR53314542-64	145.42	5.33
OR53311049-64	110.49	5.33	OR26212667-64	126.67	2.62	OR35314564-64	145.64	3.53
OR35311072-64	110.72	3.53	OR30012700-64	127.00	3.00	OR26214572-64	145.72	2.62
OR40011200-64	112.00	4.00	OR30012800-64	128.00	3.00	OR60014600-64	146.00	6.00
OR30011200-64	112.00	3.00	OR40012800-64	128.00	4.00	OR69914859-64	148.59	6.99
OR69911367-64	113.67	6.99	OR40012900-64	129.00	4.00	OR53314859-64	148.59	5.33
OR53311367-64	113.67	5.33	OR53312954-64	129.54	5.33	OR35314882-64	148.82	3.53
OR35311389-64	113.89	3.53	OR69912954-64	129.54	6.99	OR57014930-64	149.30	5.70
OR26211397-64	113.97	2.62	OR35312977-64	129.77	3.53	OR50015000-64	150.00	5.00
OR31011440-66	114.40	3.10	OR50013000-64	130.00	5.00	OR40015000-64	150.00	4.00
OR50011500-64	115.00	5.00	OR40013000-64	130.00	4.00	OR35015000-64	150.00	3.50

\* BL stands for Black Colour O-Rings  
Other O-Rings are available in Brown Colour

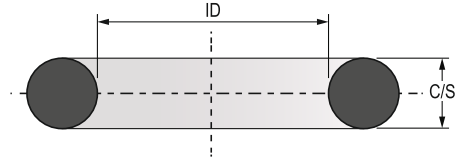
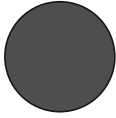

Max Spare Part No.	ID (mm)	C/S (mm)	Max Spare Part No.	ID (mm)	C/S (mm)	Max Spare Part No.	ID (mm)	C/S (mm)
OR30015000-64	150.00	3.00	OR53317717-64	177.17	5.33	OR50022000-64	220.00	5.00
OR60015000-64	150.00	6.00	OR35317739-64	177.39	3.53	OR30022000-64	220.00	3.00
OR53315177-64	151.77	5.33	OR57017930-64	179.30	5.70	OR53322162-64	221.62	5.33
OR69915177-64	151.77	6.99	OR40018000-64	180.00	4.00	OR35322184-64	221.84	3.53
OR35315199-64	151.99	3.53	OR50018000-64	180.00	5.00	OR40022500-64	225.00	4.00
OR50015200-64	152.00	5.00	OR53318352-64	183.52	5.33	OR53322797-64	227.97	5.33
OR26215207-64	152.07	2.62	OR35318374-64	183.74	3.53	OR69922797-64	227.97	6.99
OR30015400-64	154.00	3.00	OR26218382-64	183.82	2.62	OR35322819-64	228.19	3.53
OR40015500-64	155.00	4.00	OR30018500-64	185.00	3.00	OR40023000-64	230.00	4.00
OR50015500-64	155.00	5.00	OR40018800-64	188.00	4.00	OR30023000-64	230.00	3.00
OR53315812-64	158.12	5.33	OR57018930-64	189.30	5.70	OR60023000-64	230.00	6.00
OR69915812-64	158.12	6.99	OR69918987-64	189.87	6.99	OR50023000-64	230.00	5.00
OR35315834-64	158.34	3.53	OR53318987-64	189.87	5.33	OR53323432-64	234.32	5.33
OR26215842-64	158.42	2.62	OR60019000-64	190.00	6.00	OR35323454-64	234.54	3.53
OR57015930-64	159.30	5.70	OR50019000-64	190.00	5.00	OR50024000-64	240.00	5.00
OR40016000-64	160.00	4.00	OR35319009-64	190.09	3.53	OR40024000-64	240.00	4.00
OR30016000-64	160.00	3.00	OR40019200-64	192.00	4.00	OR69924067-64	240.67	6.99
OR50016000-64	160.00	5.00	OR30019300-64	193.00	3.00	OR53324067-64	240.67	5.33
OR35016000-64	160.00	3.50	OR50019500-64	195.00	5.00	OR35324089-64	240.89	3.53
OR40016200-64	162.00	4.00	OR30019500-64	195.00	3.00	OR26224097-64	240.97	2.62
OR53316447-64	164.47	5.33	OR53319622-64	196.22	5.33	OR53324702-64	247.02	5.33
OR35316469-64	164.69	3.53	OR35319644-64	196.44	3.53	OR50025000-64	250.00	5.00
OR26216477-64	164.77	2.62	OR30020000-64	200.00	3.00	OR35325359-64	253.59	3.53
OR50016500-64	165.00	5.00	OR50020000-64	200.00	5.00	OR50026000-64	260.00	5.00
OR30016500-64	165.00	3.00	OR53320257-64	202.57	5.33	OR53326607-64	266.07	5.33
OR30016700-64	167.00	3.00	OR35320279-64	202.79	3.53	OR35326629-64	266.29	3.53
OR30016800-64	168.00	3.00	OR50020500-64	205.00	5.00	OR50027000-64	270.00	5.00
OR50017000-64	170.00	5.00	OR35320700-66	207.00	3.53	OR53327877-64	278.77	5.33
OR40017000-64	170.00	4.00	OR53320892-64	208.92	5.33	OR69927877-64	278.77	6.99
OR60017000-64	170.00	6.00	OR35320914-64	209.14	3.53	OR35327899-64	278.99	3.53
OR30017000-64	170.00	3.00	OR40021000-64	210.00	4.00	OR50029000-64	290.00	5.00
OR53317082-64	170.82	5.33	OR30021000-64	210.00	3.00	OR35329169-64	291.69	3.53
OR35317104-66	171.04	3.53	OR50021000-64	210.00	5.00	OR53330417-64	304.17	5.33
OR35317104-64	171.04	3.53	OR53321527-64	215.27	5.33	OR69930417-64	304.17	6.99
OR26217112-64	171.12	2.62	OR35321549-64	215.49	3.53	OR35330439-64	304.39	3.53
OR40017500-64	175.00	4.00	OR26221557-64	215.57	2.62	OR50031500-64	315.00	5.00
OR30017500-64	175.00	3.00	OR60021800-64	218.00	6.00	OR69931687-64	316.87	6.99

\* BL stands for Black Colour O-Rings  
Other O-Rings are available in Brown Colour

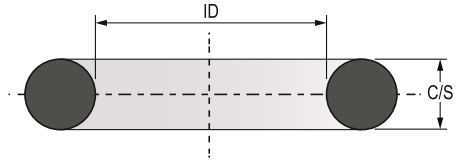
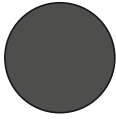

Max Spare Part No.	ID (mm)	C/S (mm)	Max Spare Part No.	ID (mm)	C/S (mm)	Max Spare Part No.	ID (mm)	C/S (mm)
OR30032000-64	320.00	3.00	OR35332979-64	329.79	3.53	OR35338059-64	380.59	3.53
OR69932957-64	329.57	6.99	OR53335497-64	354.97	5.33	OR53340526-64	405.26	5.33
OR53332957-64	329.57	5.33	OR53338037-64	380.37	5.33	OR53345606-64	456.06	5.33

Viton® is a registered trademark of Du-Pont, USA

\* BL stands for Black Colour O-Rings  
Other O-Rings are available in Brown Colour



**MATERIAL:** NBR 70<sup>0</sup> / 75<sup>0</sup> Shore 'A'  
FKM 70<sup>0</sup> / 75 Shore 'A'

**MAX OPERATING CONDITIONS :**

Temp. NBR    -30°C to +100 °C    Pressure    100 BAR

Temp. FKM    -40°C to +220 °C

**IMPERIAL ORS.KIT.201**

Max Spare Part No.	Size	Qty./ Kit	Max Spare Part No.	Size	Qty./ Kit	Max Spare Part No.	Size	Qty./ Kit
OR 178 00290	2.90 x 1.78	20	OR 262 01712	17.12 x 2.62	13	OR 353 02974	29.74 x 3.53	10
OR 178 00447	4.47 x 1.78	20	OR 262 01876	18.76 x 2.62	13	OR 353 03134	31.34 x 3.53	10
OR 178 00670	6.07 x 1.78	20	OR 262 02029	20.29 x 2.62	13	OR 353 03292	32.92 x 3.53	10
OR 178 00765	7.65 x 1.78	20	OR 262 02189	21.89 x 2.62	13	OR 353 03452	34.52 x 3.53	10
OR 178 00925	9.25 x 1.78	20	OR 353 01864	18.64 x 3.53	10	OR 353 03609	36.09 x 3.53	10
OR 178 01242	12.42 x 1.78	20	OR 353 02022	20.22 x 3.53	10	OR 353 03769	37.69 x 3.53	10
OR 262 00919	9.19 x 2.62	13	OR 353 02182	21.82 x 3.53	10	OR 353 04087	40.87 x 3.53	10
OR 262 01077	10.77 x 2.62	13	OR 353 02339	23.39 x 3.53	10	OR 353 04404	44.04 x 3.53	10
OR 262 01237	12.37 x 2.62	13	OR 353 02499	24.99 x 3.53	10	OR 353 04722	47.22 x 3.53	10
OR 262 01394	13.94 x 2.62	13	OR 353 02657	26.57 x 3.53	10	OR 353 05039	50.39 x 3.53	10
OR 262 01554	15.54 x 2.62	13	OR 353 02817	28.17 x 3.53	10			
<b>TOTAL</b>								<b>407 Nos.</b>

**METRIC ORS.KIT.202**

Max Spare Part No.	Size	Qty./ Kit	Max Spare Part No.	Size	Qty./ Kit	Max Spare Part No.	Size	Qty./ Kit
OR 200 00300	3.00 x 2.00	20	OR 250 01800	18.00 x 2.50	14	OR 350 03000	30.00 x 3.50	10
OR 200 00500	5.00 x 2.00	20	OR 250 02000	20.00 x 2.50	14	OR 350 03100	31.00 x 3.50	10
OR 200 00600	6.00 x 2.00	18	OR 250 02100	21.00 x 2.50	14	OR 350 03200	32.00 x 3.50	10
OR 200 00800	8.00 x 2.00	18	OR 250 02200	22.00 x 2.50	14	OR 350 03400	34.00 x 3.50	10
OR 200 01000	10.00 x 2.00	18	OR 350 01800	18.00 x 3.50	10	OR 350 03600	36.00 x 3.50	10
OR 200 01300	13.00 x 2.00	18	OR 350 02000	20.00 x 3.50	10	OR 350 03800	38.00 x 3.50	10
OR 250 01000	10.00 x 2.50	14	OR 350 02200	22.00 x 3.50	10	OR 350 04100	41.00 x 3.50	10
OR 250 01200	12.00 x 2.50	14	OR 350 02300	23.00 x 3.50	10	OR 350 04400	44.00 x 3.50	10
OR 250 01400	14.00 x 2.50	14	OR 350 02500	25.00 x 3.50	10	OR 350 04600	46.00 x 3.50	10
OR 250 01500	15.00 x 2.50	14	OR 350 02700	27.00 x 3.50	10	OR 350 05000	50.00 x 3.50	10
OR 250 01600	16.00 x 2.50	14	OR 350 02800	28.00 x 3.50	10			
<b>TOTAL</b>								<b>408 Nos.</b>



**IMPERIAL ORS.KIT.203**

Max Spare Part No.	Size	Qty./ Kit	Max Spare Part No.	Size	Qty./ Kit	Max Spare Part No.	Size	Qty./ Kit
OR 178 00290	2.90 x 1.78	32	OR 353 02182	21.82 x 3.53	9	OR 533 05334	53.34 x 5.33	6
OR 178 00368	3.68 x 1.78	32	OR 353 02339	23.39 x 3.53	9	OR 533 05652	56.52 x 5.33	6
OR 178 00447	4.47 x 1.78	32	OR 353 02499	24.99 x 3.53	9	OR 533 05969	59.69 x 5.33	6
OR 178 00528	5.28 x 1.78	32	OR 353 02657	26.57 x 3.53	9	OR 533 06287	62.87 x 5.33	6
OR 178 00607	6.07 x 1.78	32	OR 353 02817	28.17 x 3.53	9	OR 533 06604	66.04 x 5.33	6
OR 178 00765	7.65 x 1.78	32	OR 353 02974	29.74 x 3.53	9			
OR 178 00925	9.25 x 1.78	32	OR 353 03134	31.34 x 3.53	9	<b>TOTAL</b>	<b>492 Nos.</b>	
OR 262 00919	9.19 x 2.62	13	OR 353 03292	32.92 x 3.53	9			
OR 262 01077	10.77 x 2.62	13	OR 353 03452	34.52 x 3.53	9			
OR 262 01237	12.37 x 2.62	13	OR 353 03609	36.09 x 3.53	9			
OR 262 01394	13.94 x 2.62	13	OR 353 03769	37.69 x 3.53	9			
OR 262 01554	15.54 x 2.62	13	OR 533 03747	37.47 x 5.33	6			
OR 262 01712	17.12 x 2.62	13	OR 533 04064	40.64 x 5.33	6			
OR 262 01872	18.72 x 2.62	13	OR 533 04382	43.82 x 5.33	6			
OR 353 01864	18.64 x 3.53	9	OR 533 04699	46.99 x 5.33	6			
OR 353 02022	20.22 x 3.53	9	OR 533 05017	50.17 x 5.33	6			

**IMPERIAL ORS.KIT.204**

Max Spare Part No.	Size	Qty./ Kit	Max Spare Part No.	Size	Qty./ Kit	Max Spare Part No.	Size	Qty./ Kit
OR 178 00290	2.90 1.78	20	OR 262 01394	13.94 2.62	13	OR 353 02817	28.17 3.53	10
OR 178 00368	3.68 1.78	20	OR 262 01554	15.54 2.62	13	OR 353 02974	29.74 3.53	10
OR 178 00447	4.47 1.78	20	OR 262 01712	17.12 2.62	13	OR 353 03134	31.34 3.53	10
OR 178 00528	5.28 1.78	20	OR 262 01876	18.76 2.62	13	OR 353 03292	32.92 3.53	10
OR 178 00607	6.07 1.78	20	OR 353 01864	18.64 3.53	10	OR 353 03452	34.52 3.53	10
OR 178 00765	7.65 1.78	20	OR 353 02022	20.22 3.53	10	OR 353 03609	36.09 3.53	10
OR 178 00925	9.25 1.78	20	OR 353 02182	21.82 3.53	10	OR 353 03769	37.69 3.53	10
OR 262 00919	9.19 2.62	13	OR 353 02339	23.39 3.53	10	OR 533 03747	37.47 5.33	7
OR 262 01077	10.77 2.62	13	OR 353 02499	24.99 3.53	10	OR 533 04064	40.64 5.33	7
OR 262 01237	12.37 2.62	13	OR 353 02657	26.57 3.53	10	OR 533 04382	43.82 5.33	7
						<b>TOTAL</b>	<b>382 Nos.</b>	



**IMPERIAL ORS.KIT.206**

Max Spare Part No.	Size	Qty./ Kit	Max Spare Part No.	Size	Qty./ Kit	Max Spare Part No.	Size	Qty./ Kit
OR 200 00300	3.00 2.00	18	OR 250 01400	14.00 2.50	14	OR 300 02800	28.00 3.00	12
OR 200 00400	4.00 2.00	18	OR 250 01600	16.00 2.50	14	OR 300 03000	30.00 3.00	12
OR 200 00500	5.00 2.00	18	OR 250 01700	17.00 2.50	14	OR 300 03200	32.00 3.00	12
OR 200 00600	6.00 2.00	18	OR 250 01900	19.00 2.50	14	OR 300 03300	33.00 3.00	12
OR 200 00700	7.00 2.00	18	OR 300 01900	19.00 3.00	12	OR 300 03500	35.00 3.00	12
OR 200 00800	8.00 2.00	18	OR 300 02000	20.00 3.00	12	OR 300 03600	36.00 3.00	12
OR 200 01000	10.00 2.00	18	OR 300 02200	22.00 3.00	12	OR 300 03800	38.00 3.00	12
OR 250 01000	10.00 2.50	14	OR 300 02400	24.00 3.00	12	OR 400 03800	38.00 4.00	9
OR 250 01100	11.00 2.50	14	OR 300 02500	25.00 3.00	12	OR 400 04200	42.00 4.00	9
OR 250 01200	12.00 2.50	14	OR 300 02700	27.00 3.00	12	OR 400 04500	45.00 4.00	9
<b>TOTAL</b>								<b>407 Nos.</b>

# O - RING CORD

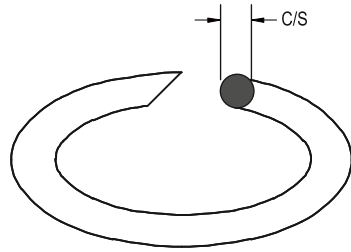
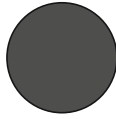

**MATERIAL :** NBR 70<sup>0</sup> / 75<sup>0</sup> shore 'A'  
FKM 70<sup>0</sup> / 75<sup>0</sup> shore 'A'

SILICON 70<sup>0</sup> / 75<sup>0</sup> shore 'A'  
PU 85 shore 'A' & 90 shore 'A'

**MAX OPERATING CONDITIONS :**

Temp. NBR	-30°C to +100 °C	Temp. Silicon	-70°C to +200 °C	Pressure	40 BAR
Temp. FKM	-40°C to +220 °C	Temp. PU	-30°C to +100 °C		

**NBR CORD**

Max Spare Part No.	C/S
CD0010803	1.00
CD0010802	1.50
CD0010801	1.78
CD0020806	2.00
CD0020802	2.50
CD0020813	2.62
CD0030801	3.00
CD0030803	3.53
CD0040801	4.00
CD0040802	4.50
CD0050801	5.00
CD0050805	5.33
CD0050803	5.50
CD0050802	5.70
CD0060801	6.00
CD0060805	6.35
CD0060802	6.50
CD0070801	7.00
CD0070802	7.50
CD0080801	8.00
CD0080803	8.50
CD0090801	9.00
CD0100801	10.00
CD0100802	10.50
CD0110802	11.00
CD0120801	12.00
CD0130801	13.00
CD0140801	14.00

CD0160801	16.00
CD0180801	18.00
CD0200801	20.00
CD0220802	22.00

**FKM CORD**

Max Spare Part No.	C/S
CD0016402	1.00
CD0016401	1.50
CD0016403	1.78
CD0026402	2.00
CD0026401	2.50
CD0026403	2.62
CD0036401	3.00
CD0036403	3.53
CD0046401	4.00
CD0046402	4.50
CD0056402	5.00
CD0056404	5.33
CD0056401	5.50
CD0066401	6.00
CD0066403	6.50
CD0076401	7.00
CD0076402	7.50
CD0086401	8.00
CD0086402	8.50
Cd0096401	9.00
CD0106401	10.00
CD0126402	12.00

**SILICON**

Max Spare Part No.	C/S
CD0014302	1.00
CD0014301	1.50
CD0014303	1.78
CD0024301	2.00
CD0024302	2.50
CD0024303	2.62
CD0034301	3.00
Cd0034303	3.53
CD0044301	4.00
CD0044302	4.50
CD0054301	5.00
CD0054303	5.33
CD0054302	5.50
CD0064301	6.00
CD0064302	6.50
CD0074301-A	7.00
CD0074302	7.50
CD0084301	8.00
CD0084302	8.50
CD0094301	9.00
CD0104302	10.00
CD0124301	12.00

**PU GREEN**

Max Spare Part No.	C/S
PRR2	2.00
PRR3	3.00
PRR4	4.00
PRR5	5.00
PRR6	6.00
PRR8	8.00
PRR10	10.00
PRR12	12.00
PRR15	15.00

Rough Surface  
Hardness 85A  
Colour Green

**PU ORANGE**

Max Spare Part No.	C/S
PRS2	2.00
PRS3	3.00
PRS4	4.00
PRS5	5.00
PRS6	6.00
PRS8	8.00
PRS10	10.00
PRS12	12.00

Smooth Surface  
Hardness 85A  
Colour Orange

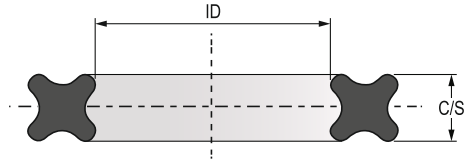

**MATERIAL:** NBR 70° / 75° Shore 'A'

**MAX OPERATING CONDITIONS :**

Temp. -30°C to +100°C

Pressure 100 BAR

**C/S = 1.78**

Max Spare Part No.	ID	OD	C/S	Max Spare Part No.	ID	OD	C/S
QR17800607-08	6.07	9.63	1.78	QR17802352-08	23.52	27.08	1.78
QR17800765-08	7.65	11.21	1.78	QR17802512-08	25.12	28.68	1.78
QR17800820-08	8.20	11.76	1.78	QR17802670-08	26.70	30.26	1.78
QR17800925-08	9.25	12.81	1.78	QR17802830-08	28.30	31.86	1.78
QR17801082-08	10.82	14.38	1.78	QR17802987-08	29.87	33.43	1.78
QR17801242-08	12.42	15.98	1.78	QR17803147-08	31.47	35.03	1.78
QR17801400-08	14.00	17.56	1.78	QR17803305-08	33.05	36.61	1.78
QR17801560-08	15.60	19.16	1.78	QR17803465-08	34.65	38.21	1.78
QR17801717-08	17.17	20.73	1.78	QR17804100-08	41.00	44.56	1.78
QR17801877-08	18.77	22.33	1.78	QR17804417-08	44.17	47.73	1.78
QR17802035-08	20.35	23.91	1.78	QR17804735-08	47.35	50.91	1.78
QR17802195-08	21.95	25.51	1.78	QR17805052-08	50.52	54.08	1.78

**C/S = 2.00**

Max Spare Part No.	ID	OD	C/S
QR20000700-08	7.00	11.00	2.00

**C/S = 3.00**

Max Spare Part No.	ID	OD	C/S
QR30001900-08	19.00	25.00	3.00

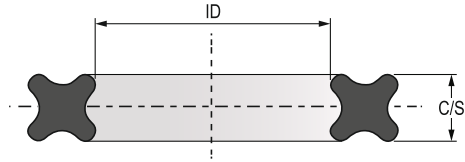

**C/S = 2.62**

Max Spare Part No.	ID	OD	C/S	Max Spare Part No.	ID	OD	C/S
QR26200919-08	9.19	14.43	2.62	QR26203777-08	37.77	43.01	2.62
QR26201002-08	10.02	15.26	2.62	QR26203934-08	39.34	44.58	2.62
QR26201077-08	10.77	16.01	2.62	QR26204095-08	40.95	46.19	2.62
QR26201237-08	12.37	17.61	2.62	QR26204252-08	42.52	47.76	2.62
QR26201470-08	14.70	19.94	2.62	QR26204412-08	44.12	49.36	2.62
QR26201555-08	15.55	20.79	2.62	QR26204729-08	47.29	52.53	2.62
QR26201620-08	16.20	21.44	2.62	QR26204890-08	48.90	54.14	2.62
QR26201712-08	17.12	22.36	2.62	QR26205047-08	50.47	55.71	2.62
QR26201960-08	19.60	24.84	2.62	QR26205207-08	52.07	57.31	2.62
QR26202029-08	20.29	25.53	2.62	QR26205384-08	53.84	59.08	2.62
QR26202189-08	21.89	27.13	2.62	QR26205525-08	55.25	60.49	2.62
QR26202507-08	25.07	30.31	2.62	QR26205682-08	56.82	62.06	2.62
QR26202664-08	26.64	31.88	2.62	QR26205842-08	58.42	63.66	2.62
QR26202824-08	28.24	33.48	2.62	QR26205999-08	59.99	65.23	2.62
QR26202982-08	29.82	35.06	2.62	QR26206160-08	61.60	66.84	2.62
QR26203142-08	31.42	36.66	2.62	QR26206317-08	63.17	68.41	2.62
QR26203299-08	32.99	38.23	2.62	QR26206477-08	64.77	70.01	2.62
QR26203459-08	34.59	39.83	2.62	QR26206794-08	67.94	73.18	2.62
QR26203617-08	36.17	41.41	2.62				

**C/S = 3.53**

Max Spare Part No.	ID	OD	C/S	Max Spare Part No.	ID	OD	C/S
QR35301866-08	18.66	25.72	3.53	QR35303452-08	34.52	41.58	3.53
QR35302022-08	20.22	27.28	3.53	QR35303609-08	36.09	43.15	3.53
QR35302182-08	21.82	28.88	3.53	QR35303769-08	37.69	44.75	3.53
QR35302340-08	23.40	30.46	3.53	QR35304087-08	40.87	47.93	3.53
QR35302500-08	25.00	32.06	3.53	QR35305040-08	50.40	57.46	3.53
QR35302657-08	26.57	33.63	3.53	QR35305357-08	53.57	60.63	3.53
QR35302817-08	28.17	35.23	3.53	QR35305675-08	56.75	63.81	3.53
QR35302974-08	29.74	36.80	3.53	QR35305992-08	59.92	66.98	3.53
QR35303134-08	31.34	38.40	3.53	QR35306627-08	66.27	73.33	3.53
QR35303292-08	32.92	39.98	3.53	QR35315199-08	151.99	159.05	3.53

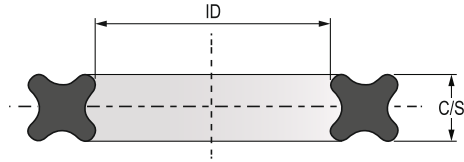

**C/S = 5.33**

Max Spare Part No.	ID	OD	C/S	Max Spare Part No.	ID	OD	C/S
QR53304064-08	40.64	51.30	5.33	QR53307874-08	78.74	89.40	5.33
QR53304380-08	43.80	50.86	5.33	QR53308190-08	81.90	92.56	5.33
QR53304520-08	45.20	55.86	5.33	QR53308509-08	85.09	95.75	5.33
QR53304700-08	47.00	57.66	5.33	QR53308826-08	88.26	98.92	5.33
QR53305016-08	50.16	60.82	5.33	QR53308920-08	89.20	99.86	5.33
QR53305334-08	53.34	64.00	5.33	QR53309145-08	91.45	102.11	5.33
QR53305650-08	56.50	67.16	5.33	QR53309462-08	94.62	105.28	5.33
QR53305970-08	59.70	70.36	5.33	QR53309779-08	97.79	108.45	5.33
QR53306286-08	62.86	73.52	5.33	QR53310097-08	100.97	111.63	5.33
QR53306600-08	66.00	76.66	5.33	QR53311049-08	110.49	121.15	5.33
QR53306922-08	69.22	79.88	5.33	QR53311367-08	113.67	124.33	5.33
QR53307240-08	72.40	83.06	5.33	QR53311685-08	116.85	127.51	5.33
QR53307556-08	75.56	86.22	5.33	QR53317717-08	177.17	187.83	5.33

**C/S = 6.99**

Max Spare Part No.	ID	OD	C/S	Max Spare Part No.	ID	OD	C/S
QR69918352-08	183.52	197.50	6.99	QR69929147-08	291.47	305.45	6.99
QR69919622-08	196.22	210.20	6.99	QR69931687-08	316.87	330.85	6.99

**C/S = 7.00**

Max Spare Part No.	ID	OD	C/S	Max Spare Part No.	ID	OD	C/S
QR70011366-08	113.66	127.66	7.00	QR70014540-08	145.40	159.40	7.00
QR70012000-08	120.00	134.00	7.00	QR70014860-08	148.60	162.60	7.00
QR70012320-08	123.20	137.20	7.00	QR70015176-08	151.76	165.76	7.00
QR70012636-08	126.36	140.36	7.00	QR70015810-08	158.10	172.10	7.00
QR70012955-08	129.55	143.55	7.00	QR70016050-08	160.50	174.50	7.00
QR70013590-08	135.90	149.90	7.00	QR70016446-08	164.46	178.46	7.00
QR70013906-08	139.06	153.06	7.00	QR70017716-08	177.16	191.16	7.00
QR70014225-08	142.25	156.25	7.00				

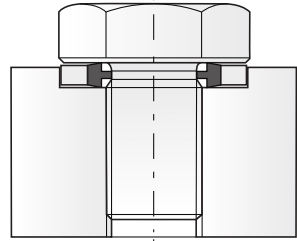
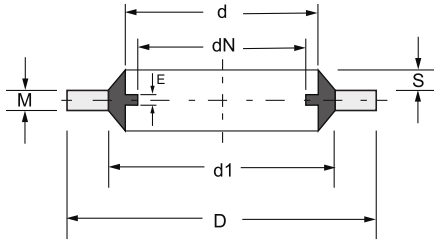

**MATERIAL:** NBR 70<sup>0</sup>/ 75<sup>0</sup>Shore 'A'  
FKM 70<sup>0</sup>/ 75<sup>0</sup>Shore 'A'

**MAX OPERATING CONDITIONS :**

Temp. NBR	-30°C to +100 °C	Pressure	1000 BAR
Temp. FKM	-40°C to +220 °C		

Max Spare Part No.		Size		D +0.13/ -0.00	d1 ±0.10	d ±0.10	dN	S	M ±0.15
NBR	FKM	BSP	BOLT						
B01 0061002	B010066603	-	0.25	13.34	9.53	6.99	0	0.20/0.45	1.22
B01 0101001	B010106602	1/8	0.38	15.88	11.84	10.37	8.26	0.25/0.51	2.03
B010101005	B010106606	-	-	16	12.4	10.7	0	0.4	1.5
B01 0131001	B010136601	1/4	0.5	20.57	15.21	13.74	11.18	0.25/0.51	2.03
B01 0171001	B010176601	3/8	-	23.8	18.75	17.28	14.76	0.25/0.51	2.03
B01 0211001	B010216601	1/2	13/16.	28.58	23.01	21.54	18.24	0.25/0.51	2.49
B01 0231001	B010236601	5/8	0.88	31.75	24.97	23.49	20.27	0.25/0.51	2.49
B01 0271001	B010276601	3/4	1	34.93	28.53	27.05	23.83	0.25/0.51	2.49
B01 0301001	B010306601	7/8	1.3/16	38.1	32.29	30.81	27.51	0.25/0.51	3.38
B01 0331002	B010336601	1	1.5/16	42.8	36.88	33.89	29.92	0.25/0.51	3.38
B01 0421001	B010426601	1.1/4	1.5/8	52.38	45.93	42.93	38.45	0.25/0.51	3.38
B01 0481001	B010486601	1.1/2	1.7/8	58.6	51.39	48.44	44.45	0.25/0.51	3.38
B01 0541001	B010546601	1.3/4	2.1/8	69.85	58.3	54.89	50.42	0.25/0.51	3.38
B010601001	B010606601	2	-	73.03	63.63	60.58	56.26	0.25/0.51	3.38
B01 0661001	B010666601	2.1/4	-	79.5	69.98	66.68	62.36	0.25/0.51	3.38
B01 0761001	B010766601	2.1/2	-	90.17	79.38	76.08	71.5	0.25/0.51	3.38
B01 0891001	B010896601	3	-	101.47	92.84	89.09	0	0.25/0.51	3.38

**NOTE :** Bonded seal with centre lip is available in both NBR & FKM materials.

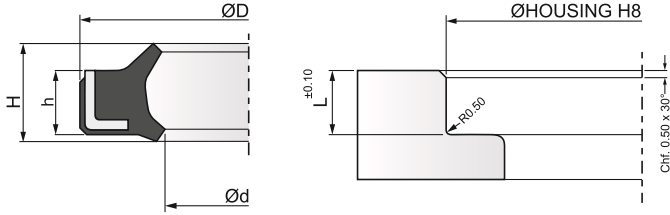

**MATERIAL:** NBR 70° / 75° Shore 'A'  
Metal Insert : Mild Steel

**MAX OPERATING CONDITIONS :**

Temp. -30°C to +100°C      Pressure 100 BAR

Max Spare Part No.	d	D	Seal Ht.	L (+0.2)	Max Spare Part No.	d	D	Seal Ht.	L (+0.2)
A050200802	20.00	45.00	9.50/14.50	10.00	A050930801	93.00	125.00	9.50/14.50	10.00
A050310801	31.00	40.00	5.00/7.00	5.50	A050950801	95.00	120.00	9.50/14.50	10.00
A050500802	50.00	75.00	9.50/14.50	10.00	A051000801	100.00	125.00	9.50/14.50	10.00
A050650801	65.00	90.00	9.50/14.50	10.00	A051450801	145.00	170.00	9.50/13.00	10.00
A050730801	73.00	105.00	9.50/14.50	10.00	A051700801	170.00	195.00	9.50/14.50	10.00
A050800802	80.00	100.00	9.50/14.50	10.00	A052250801	225.00	250.00	9.50/14.50	10.00
A050800801	80.00	105.00	9.50/14.50	10.00	A052450801	245.00	270.00	9.50/14.50	10.00

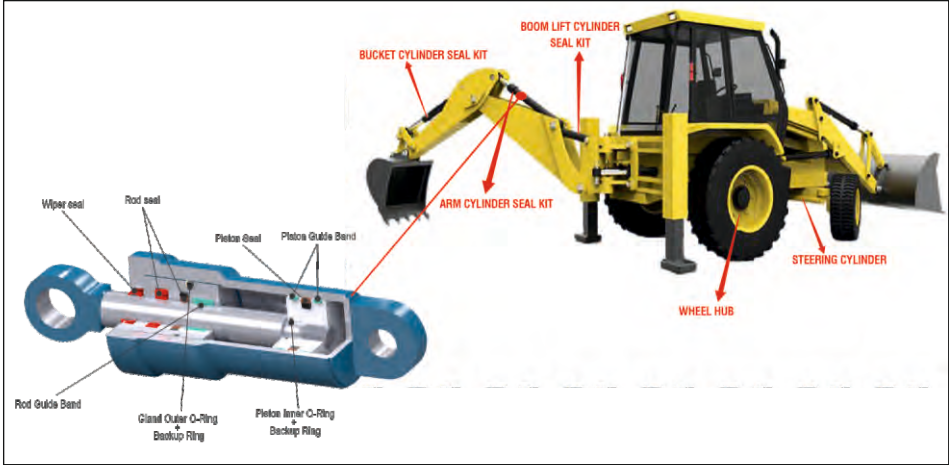

Maxpare Earthmoving Seal Kits are now available in the domestic market. Our company holds one of the most commendable position in the global industry for earth moving seals. This precision engineered seal kits are manufactured by our team of trained professionals using the finest quality raw materials from renowned vendors and state-of-the-art technology.

Below Earthmoving & Mining Machine Seals are readily available

BACKHOE LOADER	Model
JCB	4DX, 3DX-ECO, 2DX, 5D, 4CX, 3CX, 4D, JCB OTHERS
L & T CASE	770/851 FX, 770 EX
TAREX VECTRA	CAT-424, CAT-424B
CAT	TX-760, TX-740
TATA HITACHI	JD315 D, JD315E
ESCORT DIGIMAX	
MAHINDRA	2104SAA0, 2104SAA0-(D)2017, 2104SAA0SPARE ITEM
BOBCAT	

EXCAVATOR	Model
TATA HITACHI	EX-60/65/70, EX-70, EX-100, EX-110, EX-200, EX-210, EX-300, EX-350, EX-370
JCB	JS75/80, JS140, JS205, JS210, JS215
SANY	SANY-75/80, SANY-135/140, SANY-210, SANY-215, SANY-240
L & T KOMATSU	PC-60/7-PC71, PC-81, PC-130-7, PC-136, PC-200-6, PC-210-8, PC-300-7
HYUNDAI	R80, R110, R140, R160 LC-7, R210, R215, R220
Z-AXIS	ZAXIS-120, ZAXIS-210/220
KUBELCO	SK-140-8, SK210/200-8, SK-210 HD/WIPRO

The above seal kits are readily available with our authorized distributors. Kindly contact Max Sales office for more details.

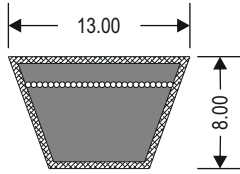

Standard : IS 2494, BS 3790, ISO 4184

Dimensions in mm		Angle Degree	Rec. Min Pulley Dia. mm	Manufacturing Range
Top Width	Thickness			
13	8	40	71	16 to 450 inch

Nominal Length (Inches) : Inside Length (Li)

A-16	A-53	A-90	A-127	A-164	A-201	A-238	A-275	A-312	A-349	A-386	A-423
A-17	A-54	A-91	A-128	A-165	A-202	A-239	A-276	A-313	A-350	A-387	A-424
A-18	A-55	A-92	A-129	A-166	A-203	A-240	A-277	A-314	A-351	A-388	A-425
A-19	A-56	A-93	A-130	A-167	A-204	A-241	A-278	A-315	A-352	A-389	A-426
A-20	A-57	A-94	A-131	A-168	A-205	A-242	A-279	A-316	A-353	A-390	A-427
A-21	A-58	A-95	A-132	A-169	A-206	A-243	A-280	A-317	A-354	A-391	A-428
A-22	A-59	A-96	A-133	A-170	A-207	A-244	A-281	A-318	A-355	A-392	A-429
A-23	A-60	A-97	A-134	A-171	A-208	A-245	A-282	A-319	A-356	A-393	A-430
A-24	A-61	A-98	A-135	A-172	A-209	A-246	A-283	A-320	A-357	A-394	A-431
A-25	A-62	A-99	A-136	A-173	A-210	A-247	A-284	A-321	A-358	A-395	A-432
A-26	A-63	A-100	A-137	A-174	A-211	A-248	A-285	A-322	A-359	A-396	A-433
A-27	A-64	A-101	A-138	A-175	A-212	A-249	A-286	A-323	A-360	A-397	A-434
A-28	A-65	A-102	A-139	A-176	A-213	A-250	A-287	A-324	A-361	A-398	A-435
A-29	A-66	A-103	A-140	A-177	A-214	A-251	A-288	A-325	A-362	A-399	A-436
A-30	A-67	A-104	A-141	A-178	A-215	A-252	A-289	A-326	A-363	A-400	A-437
A-31	A-68	A-105	A-142	A-179	A-216	A-253	A-290	A-327	A-364	A-401	A-438
A-32	A-69	A-106	A-143	A-180	A-217	A-254	A-291	A-328	A-365	A-402	A-439
A-33	A-70	A-107	A-144	A-181	A-218	A-255	A-292	A-329	A-366	A-403	A-440
A-34	A-71	A-108	A-145	A-182	A-219	A-256	A-293	A-330	A-367	A-404	A-441
A-35	A-72	A-109	A-146	A-183	A-220	A-257	A-294	A-331	A-368	A-405	A-442
A-36	A-73	A-110	A-147	A-184	A-221	A-258	A-295	A-332	A-369	A-406	A-443
A-37	A-74	A-111	A-148	A-185	A-222	A-259	A-296	A-333	A-370	A-407	A-444
A-38	A-75	A-112	A-149	A-186	A-223	A-260	A-297	A-334	A-371	A-408	A-445
A-39	A-76	A-113	A-150	A-187	A-224	A-261	A-298	A-335	A-372	A-409	A-446
A-40	A-77	A-114	A-151	A-188	A-225	A-262	A-299	A-336	A-373	A-410	A-447
A-41	A-78	A-115	A-152	A-189	A-226	A-263	A-300	A-337	A-374	A-411	A-448
A-42	A-79	A-116	A-153	A-190	A-227	A-264	A-301	A-338	A-375	A-412	A-449
A-43	A-80	A-117	A-154	A-191	A-228	A-265	A-302	A-339	A-376	A-413	A-450
A-44	A-81	A-118	A-155	A-192	A-229	A-266	A-303	A-340	A-377	A-414	
A-45	A-82	A-119	A-156	A-193	A-230	A-267	A-304	A-341	A-378	A-415	
A-46	A-83	A-120	A-157	A-194	A-231	A-268	A-305	A-342	A-379	A-416	
A-47	A-84	A-121	A-158	A-195	A-232	A-269	A-306	A-343	A-380	A-417	
A-48	A-85	A-122	A-159	A-196	A-233	A-270	A-307	A-344	A-381	A-418	
A-49	A-86	A-123	A-160	A-197	A-234	A-271	A-308	A-345	A-382	A-419	
A-50	A-87	A-124	A-161	A-198	A-235	A-272	A-309	A-346	A-383	A-420	
A-51	A-88	A-125	A-162	A-199	A-236	A-273	A-310	A-347	A-384	A-421	
A-52	A-89	A-126	A-163	A-200	A-237	A-274	A-311	A-348	A-385	A-422	

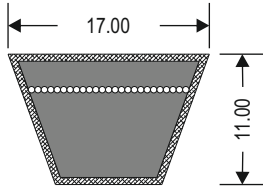

Standard : IS 2494, BS 3790, ISO 4184

Dimensions in mm		Angle Degree	Rec. Min Pulley Dia. mm	Manufacturing Range
Top Width	Thickness			
17	11	40	112	19 to 598 inch

Nominal Length (Inches) : Inside Length (Li)

B-19	B-56	B-93	B-130	B-167	B-204	B-241	B-278	B-315	B-352	B-389	B-426
B-20	B-57	B-94	B-131	B-168	B-205	B-242	B-279	B-316	B-353	B-390	B-427
B-21	B-58	B-95	B-132	B-169	B-206	B-243	B-280	B-317	B-354	B-391	B-428
B-22	B-59	B-96	B-133	B-170	B-207	B-244	B-281	B-318	B-355	B-392	B-429
B-23	B-60	B-97	B-134	B-171	B-208	B-245	B-282	B-319	B-356	B-393	B-430
B-24	B-61	B-98	B-135	B-172	B-209	B-246	B-283	B-320	B-357	B-394	B-431
B-25	B-62	B-99	B-136	B-173	B-210	B-247	B-284	B-321	B-358	B-395	B-432
B-26	B-63	B-100	B-137	B-174	B-211	B-248	B-285	B-322	B-359	B-396	B-433
B-27	B-64	B-101	B-138	B-175	B-212	B-249	B-286	B-323	B-360	B-397	B-434
B-28	B-65	B-102	B-139	B-176	B-213	B-250	B-287	B-324	B-361	B-398	B-435
B-29	B-66	B-103	B-140	B-177	B-214	B-251	B-288	B-325	B-362	B-399	B-436
B-30	B-67	B-104	B-141	B-178	B-215	B-252	B-289	B-326	B-363	B-400	B-437
B-31	B-68	B-105	B-142	B-179	B-216	B-253	B-290	B-327	B-364	B-401	B-438
B-32	B-69	B-106	B-143	B-180	B-217	B-254	B-291	B-328	B-365	B-402	B-439
B-33	B-70	B-107	B-144	B-181	B-218	B-255	B-292	B-329	B-366	B-403	B-440
B-34	B-71	B-108	B-145	B-182	B-219	B-256	B-293	B-330	B-367	B-404	B-441
B-35	B-72	B-109	B-146	B-183	B-220	B-257	B-294	B-331	B-368	B-405	B-442
B-36	B-73	B-110	B-147	B-184	B-221	B-258	B-295	B-332	B-369	B-406	B-443
B-37	B-74	B-111	B-148	B-185	B-222	B-259	B-296	B-333	B-370	B-407	B-444
B-38	B-75	B-112	B-149	B-186	B-223	B-260	B-297	B-334	B-371	B-408	B-445
B-39	B-76	B-113	B-150	B-187	B-224	B-261	B-298	B-335	B-372	B-409	B-446
B-40	B-77	B-114	B-151	B-188	B-225	B-262	B-299	B-336	B-373	B-410	B-447
B-41	B-78	B-115	B-152	B-189	B-226	B-263	B-300	B-337	B-374	B-411	B-448
B-42	B-79	B-116	B-153	B-190	B-227	B-264	B-301	B-338	B-375	B-412	B-449
B-43	B-80	B-117	B-154	B-191	B-228	B-265	B-302	B-339	B-376	B-413	B-450
B-44	B-81	B-118	B-155	B-192	B-229	B-266	B-303	B-340	B-377	B-414	B-451
B-45	B-82	B-119	B-156	B-193	B-230	B-267	B-304	B-341	B-378	B-415	B-452
B-46	B-83	B-120	B-157	B-194	B-231	B-268	B-305	B-342	B-379	B-416	B-453
B-47	B-84	B-121	B-158	B-195	B-232	B-269	B-306	B-343	B-380	B-417	B-454
B-48	B-85	B-122	B-159	B-196	B-233	B-270	B-307	B-344	B-381	B-418	B-455
B-49	B-86	B-123	B-160	B-197	B-234	B-271	B-308	B-345	B-382	B-419	B-456
B-50	B-87	B-124	B-161	B-198	B-235	B-272	B-309	B-346	B-383	B-420	B-457
B-51	B-88	B-125	B-162	B-199	B-236	B-273	B-310	B-347	B-384	B-421	B-458
B-52	B-89	B-126	B-163	B-200	B-237	B-274	B-311	B-348	B-385	B-422	B-459
B-53	B-90	B-127	B-164	B-201	B-238	B-275	B-312	B-349	B-386	B-423	B-460
B-54	B-91	B-128	B-165	B-202	B-239	B-276	B-313	B-350	B-387	B-424	B-461
B-55	B-92	B-129	B-166	B-203	B-240	B-277	B-314	B-351	B-388	B-425	B-462

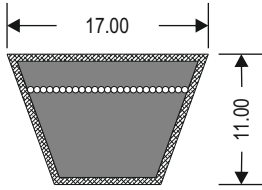

Standard : IS 2494, BS 3790, ISO 4184

Dimensions in mm		Angle Degree	Rec. Min Pulley Dia. mm	Manufacturing Range
Top Width	Thickness			
17	11	40	112	19 to 598 inch

Nominal Length (Inches) : Inside Length (Li)

B-463	B-475	B-487	B-499	B-511	B-523	B-535	B-547	B-559	B-571	B-583	B-595
B-464	B-476	B-488	B-500	B-512	B-524	B-536	B-548	B-560	B-572	B-584	B-596
B-465	B-477	B-489	B-501	B-513	B-525	B-537	B-549	B-561	B-573	B-585	B-597
B-466	B-478	B-490	B-502	B-514	B-526	B-538	B-550	B-562	B-574	B-586	B-598
B-467	B-479	B-491	B-503	B-515	B-527	B-539	B-551	B-563	B-575	B-587	
B-468	B-480	B-492	B-504	B-516	B-528	B-540	B-552	B-564	B-576	B-588	
B-469	B-481	B-493	B-505	B-517	B-529	B-541	B-553	B-565	B-577	B-589	
B-470	B-482	B-494	B-506	B-518	B-530	B-542	B-554	B-566	B-578	B-590	
B-471	B-483	B-495	B-507	B-519	B-531	B-543	B-555	B-567	B-579	B-591	
B-472	B-484	B-496	B-508	B-520	B-532	B-544	B-556	B-568	B-580	B-592	
B-473	B-485	B-497	B-509	B-521	B-533	B-545	B-557	B-569	B-581	B-593	
B-474	B-486	B-498	B-510	B-522	B-534	B-546	B-558	B-570	B-582	B-594	

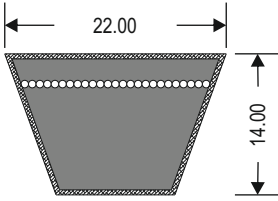

Standard : IS 2494, BS 3790, ISO 4184				
Dimensions in mm		Angle Degree	Rec. Min Pulley Dia. mm	Manufacturing Range
Top Width	Thickness			
22	14	40	180	32 to 598 inch

Nominal Length (Inches) : Inside Length (Li)

C-32	C-69	C-106	C-143	C-180	C-217	C-254	C-291	C-328	C-365	C-402	C-439
C-33	C-70	C-107	C-144	C-181	C-218	C-255	C-292	C-329	C-366	C-403	C-440
C-34	C-71	C-108	C-145	C-182	C-219	C-256	C-293	C-330	C-367	C-404	C-441
C-35	C-72	C-109	C-146	C-183	C-220	C-257	C-294	C-331	C-368	C-405	C-442
C-36	C-73	C-110	C-147	C-184	C-221	C-258	C-295	C-332	C-369	C-406	C-443
C-37	C-74	C-111	C-148	C-185	C-222	C-259	C-296	C-333	C-370	C-407	C-444
C-38	C-75	C-112	C-149	C-186	C-223	C-260	C-297	C-334	C-371	C-408	C-445
C-39	C-76	C-113	C-150	C-187	C-224	C-261	C-298	C-335	C-372	C-409	C-446
C-40	C-77	C-114	C-151	C-188	C-225	C-262	C-299	C-336	C-373	C-410	C-447
C-41	C-78	C-115	C-152	C-189	C-226	C-263	C-300	C-337	C-374	C-411	C-448
C-42	C-79	C-116	C-153	C-190	C-227	C-264	C-301	C-338	C-375	C-412	C-449
C-43	C-80	C-117	C-154	C-191	C-228	C-265	C-302	C-339	C-376	C-413	C-450
C-44	C-81	C-118	C-155	C-192	C-229	C-266	C-303	C-340	C-377	C-414	C-451
C-45	C-82	C-119	C-156	C-193	C-230	C-267	C-304	C-341	C-378	C-415	C-452
C-46	C-83	C-120	C-157	C-194	C-231	C-268	C-305	C-342	C-379	C-416	C-453
C-47	C-84	C-121	C-158	C-195	C-232	C-269	C-306	C-343	C-380	C-417	C-454
C-48	C-85	C-122	C-159	C-196	C-233	C-270	C-307	C-344	C-381	C-418	C-455
C-49	C-86	C-123	C-160	C-197	C-234	C-271	C-308	C-345	C-382	C-419	C-456
C-50	C-87	C-124	C-161	C-198	C-235	C-272	C-309	C-346	C-383	C-420	C-457
C-51	C-88	C-125	C-162	C-199	C-236	C-273	C-310	C-347	C-384	C-421	C-458
C-52	C-89	C-126	C-163	C-200	C-237	C-274	C-311	C-348	C-385	C-422	C-459
C-53	C-90	C-127	C-164	C-201	C-238	C-275	C-312	C-349	C-386	C-423	C-460
C-54	C-91	C-128	C-165	C-202	C-239	C-276	C-313	C-350	C-387	C-424	C-461
C-55	C-92	C-129	C-166	C-203	C-240	C-277	C-314	C-351	C-388	C-425	C-462
C-56	C-93	C-130	C-167	C-204	C-241	C-278	C-315	C-352	C-389	C-426	C-463
C-57	C-94	C-131	C-168	C-205	C-242	C-279	C-316	C-353	C-390	C-427	C-464
C-58	C-95	C-132	C-169	C-206	C-243	C-280	C-317	C-354	C-391	C-428	C-465
C-59	C-96	C-133	C-170	C-207	C-244	C-281	C-318	C-355	C-392	C-429	C-466
C-60	C-97	C-134	C-171	C-208	C-245	C-282	C-319	C-356	C-393	C-430	C-467
C-61	C-98	C-135	C-172	C-209	C-246	C-283	C-320	C-357	C-394	C-431	C-468
C-62	C-99	C-136	C-173	C-210	C-247	C-284	C-321	C-358	C-395	C-432	C-469
C-63	C-100	C-137	C-174	C-211	C-248	C-285	C-322	C-359	C-396	C-433	C-470
C-64	C-101	C-138	C-175	C-212	C-249	C-286	C-323	C-360	C-397	C-434	C-471
C-65	C-102	C-139	C-176	C-213	C-250	C-287	C-324	C-361	C-398	C-435	C-472
C-66	C-103	C-140	C-177	C-214	C-251	C-288	C-325	C-362	C-399	C-436	C-473
C-67	C-104	C-141	C-178	C-215	C-252	C-289	C-326	C-363	C-400	C-437	C-474
C-68	C-105	C-142	C-179	C-216	C-253	C-290	C-327	C-364	C-401	C-438	C-475

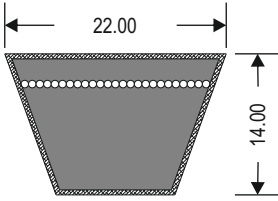

Standard : IS 2494, BS 3790, ISO 4184

Dimensions in mm		Angle Degree	Rec. Min Pulley Dia. mm	Manufacturing Range
Top Width	Thickness			
22	14	40	180	32 to 598 inch

Nominal Length (Inches) : Inside Length (Li)

C-476	C-486	C-496	C-506	C-516	C-526	C-536	C-546	C-556	C-566	C-576	C-586
C-477	C-487	C-497	C-507	C-517	C-527	C-537	C-547	C-557	C-567	C-577	C-587
C-478	C-488	C-498	C-508	C-518	C-528	C-538	C-548	C-558	C-568	C-578	C-588
C-479	C-489	C-499	C-509	C-519	C-529	C-539	C-549	C-559	C-569	C-579	C-589
C-480	C-490	C-500	C-510	C-520	C-530	C-540	C-550	C-560	C-570	C-580	C-590
C-481	C-491	C-501	C-511	C-521	C-531	C-541	C-551	C-561	C-571	C-581	
C-482	C-492	C-502	C-512	C-522	C-532	C-542	C-552	C-562	C-572	C-582	
C-483	C-493	C-503	C-513	C-523	C-533	C-543	C-553	C-563	C-573	C-583	
C-484	C-494	C-504	C-514	C-524	C-534	C-544	C-554	C-564	C-574	C-584	
C-485	C-495	C-505	C-515	C-525	C-535	C-545	C-555	C-565	C-575	C-585	

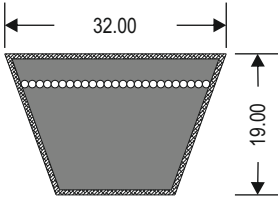

Standard : IS 2494, BS 3790, ISO 4184

Dimensions in mm		Angle Degree	Rec. Min Pulley Dia. mm	Manufacturing Range
Top Width	Thickness			
32	19	40	355	75 to 598 inch

Nominal Length (Inches) : Inside Length (Li)

D-75	D-112	D-149	D-186	D-223	D-260	D-297	D-334	D-371	D-408	D-445	D-482
D-76	D-113	D-150	D-187	D-224	D-261	D-298	D-335	D-372	D-409	D-446	D-483
D-77	D-114	D-151	D-188	D-225	D-262	D-299	D-336	D-373	D-410	D-447	D-484
D-78	D-115	D-152	D-189	D-226	D-263	D-300	D-337	D-374	D-411	D-448	D-485
D-79	D-116	D-153	D-190	D-227	D-264	D-301	D-338	D-375	D-412	D-449	D-486
D-80	D-117	D-154	D-191	D-228	D-265	D-302	D-339	D-376	D-413	D-450	D-487
D-81	D-118	D-155	D-192	D-229	D-266	D-303	D-340	D-377	D-414	D-451	D-488
D-82	D-119	D-156	D-193	D-230	D-267	D-304	D-341	D-378	D-415	D-452	D-489
D-83	D-120	D-157	D-194	D-231	D-268	D-305	D-342	D-379	D-416	D-453	D-490
D-84	D-121	D-158	D-195	D-232	D-269	D-306	D-343	D-380	D-417	D-454	D-491
D-85	D-122	D-159	D-196	D-233	D-270	D-307	D-344	D-381	D-418	D-455	D-492
D-86	D-123	D-160	D-197	D-234	D-271	D-308	D-345	D-382	D-419	D-456	D-493
D-87	D-124	D-161	D-198	D-235	D-272	D-309	D-346	D-383	D-420	D-457	D-494
D-88	D-125	D-162	D-199	D-236	D-273	D-310	D-347	D-384	D-421	D-458	D-495
D-89	D-126	D-163	D-200	D-237	D-274	D-311	D-348	D-385	D-422	D-459	D-496
D-90	D-127	D-164	D-201	D-238	D-275	D-312	D-349	D-386	D-423	D-460	D-497
D-91	D-128	D-165	D-202	D-239	D-276	D-313	D-350	D-387	D-424	D-461	D-498
D-92	D-129	D-166	D-203	D-240	D-277	D-314	D-351	D-388	D-425	D-462	D-499
D-93	D-130	D-167	D-204	D-241	D-278	D-315	D-352	D-389	D-426	D-463	D-500
D-94	D-131	D-168	D-205	D-242	D-279	D-316	D-353	D-390	D-427	D-464	D-501
D-95	D-132	D-169	D-206	D-243	D-280	D-317	D-354	D-391	D-428	D-465	D-502
D-96	D-133	D-170	D-207	D-244	D-281	D-318	D-355	D-392	D-429	D-466	D-503
D-97	D-134	D-171	D-208	D-245	D-282	D-319	D-356	D-393	D-430	D-467	D-504
D-98	D-135	D-172	D-209	D-246	D-283	D-320	D-357	D-394	D-431	D-468	D-505
D-99	D-136	D-173	D-210	D-247	D-284	D-321	D-358	D-395	D-432	D-469	D-506
D-100	D-137	D-174	D-211	D-248	D-285	D-322	D-359	D-396	D-433	D-470	D-507
D-101	D-138	D-175	D-212	D-249	D-286	D-323	D-360	D-397	D-434	D-471	D-508
D-102	D-139	D-176	D-213	D-250	D-287	D-324	D-361	D-398	D-435	D-472	D-509
D-103	D-140	D-177	D-214	D-251	D-288	D-325	D-362	D-399	D-436	D-473	D-510
D-104	D-141	D-178	D-215	D-252	D-289	D-326	D-363	D-400	D-437	D-474	D-511
D-105	D-142	D-179	D-216	D-253	D-290	D-327	D-364	D-401	D-438	D-475	D-512
D-106	D-143	D-180	D-217	D-254	D-291	D-328	D-365	D-402	D-439	D-476	D-513
D-107	D-144	D-181	D-218	D-255	D-292	D-329	D-366	D-403	D-440	D-477	D-514
D-108	D-145	D-182	D-219	D-256	D-293	D-330	D-367	D-404	D-441	D-478	D-515
D-109	D-146	D-183	D-220	D-257	D-294	D-331	D-368	D-405	D-442	D-479	D-516
D-110	D-147	D-184	D-221	D-258	D-295	D-332	D-369	D-406	D-443	D-480	D-517
D-111	D-148	D-185	D-222	D-259	D-296	D-333	D-370	D-407	D-444	D-481	D-518

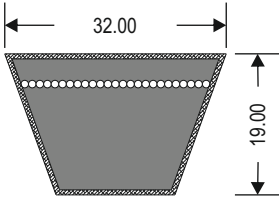

Standard : IS 2494, BS 3790, ISO 4184				
Dimensions in mm		Angle Degree	Rec. Min Pulley Dia. mm	Manufacturing Range
Top Width	Thickness			
32	19	40	355	75 to 598 inch

Nominal Length (Inches) : Inside Length (Li)

D-519	D-525	D-531	D-537	D-543	D-549	D-555	D-561	D-567	D-573	D-579	D-585
D-520	D-526	D-532	D-538	D-544	D-550	D-556	D-562	D-568	D-574	D-580	D-586
D-521	D-527	D-533	D-539	D-545	D-551	D-557	D-563	D-569	D-575	D-581	D-587
D-522	D-528	D-534	D-540	D-546	D-552	D-558	D-564	D-570	D-576	D-582	D-588
D-523	D-529	D-535	D-541	D-547	D-553	D-559	D-565	D-571	D-577	D-583	D-589
D-524	D-530	D-536	D-542	D-548	D-554	D-560	D-566	D-572	D-578	D-584	D-590

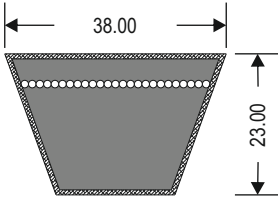

Standard : IS 2494, BS 3790, ISO 4184				
Dimensions in mm		Angle Degree	Rec. Min Pulley Dia. mm	Manufacturing Range
Top Width	Thickness			
38	23	40	500	90 to 598 inch

Nominal Length (Inches) : Inside Length (Li)

E-90	E-127	E-164	E-201	E-238	E-275	E-312	E-349	E-386	E-423	E-460	E-497
E-91	E-128	E-165	E-202	E-239	E-276	E-313	E-350	E-387	E-424	E-461	E-498
E-92	E-129	E-166	E-203	E-240	E-277	E-314	E-351	E-388	E-425	E-462	E-499
E-93	E-130	E-167	E-204	E-241	E-278	E-315	E-352	E-389	E-426	E-463	E-500
E-94	E-131	E-168	E-205	E-242	E-279	E-316	E-353	E-390	E-427	E-464	E-501
E-95	E-132	E-169	E-206	E-243	E-280	E-317	E-354	E-391	E-428	E-465	E-502
E-96	E-133	E-170	E-207	E-244	E-281	E-318	E-355	E-392	E-429	E-466	E-503
E-97	E-134	E-171	E-208	E-245	E-282	E-319	E-356	E-393	E-430	E-467	E-504
E-98	E-135	E-172	E-209	E-246	E-283	E-320	E-357	E-394	E-431	E-468	E-505
E-99	E-136	E-173	E-210	E-247	E-284	E-321	E-358	E-395	E-432	E-469	E-506
E-100	E-137	E-174	E-211	E-248	E-285	E-322	E-359	E-396	E-433	E-470	E-507
E-101	E-138	E-175	E-212	E-249	E-286	E-323	E-360	E-397	E-434	E-471	E-508
E-102	E-139	E-176	E-213	E-250	E-287	E-324	E-361	E-398	E-435	E-472	E-509
E-103	E-140	E-177	E-214	E-251	E-288	E-325	E-362	E-399	E-436	E-473	E-510
E-104	E-141	E-178	E-215	E-252	E-289	E-326	E-363	E-400	E-437	E-474	E-511
E-105	E-142	E-179	E-216	E-253	E-290	E-327	E-364	E-401	E-438	E-475	E-512
E-106	E-143	E-180	E-217	E-254	E-291	E-328	E-365	E-402	E-439	E-476	E-513
E-107	E-144	E-181	E-218	E-255	E-292	E-329	E-366	E-403	E-440	E-477	E-514
E-108	E-145	E-182	E-219	E-256	E-293	E-330	E-367	E-404	E-441	E-478	E-515
E-109	E-146	E-183	E-220	E-257	E-294	E-331	E-368	E-405	E-442	E-479	E-516
E-110	E-147	E-184	E-221	E-258	E-295	E-332	E-369	E-406	E-443	E-480	E-517
E-111	E-148	E-185	E-222	E-259	E-296	E-333	E-370	E-407	E-444	E-481	E-518
E-112	E-149	E-186	E-223	E-260	E-297	E-334	E-371	E-408	E-445	E-482	E-519
E-113	E-150	E-187	E-224	E-261	E-298	E-335	E-372	E-409	E-446	E-483	E-520
E-114	E-151	E-188	E-225	E-262	E-299	E-336	E-373	E-410	E-447	E-484	E-521
E-115	E-152	E-189	E-226	E-263	E-300	E-337	E-374	E-411	E-448	E-485	E-522
E-116	E-153	E-190	E-227	E-264	E-301	E-338	E-375	E-412	E-449	E-486	E-523
E-117	E-154	E-191	E-228	E-265	E-302	E-339	E-376	E-413	E-450	E-487	E-524
E-118	E-155	E-192	E-229	E-266	E-303	E-340	E-377	E-414	E-451	E-488	E-525
E-119	E-156	E-193	E-230	E-267	E-304	E-341	E-378	E-415	E-452	E-489	E-526
E-120	E-157	E-194	E-231	E-268	E-305	E-342	E-379	E-416	E-453	E-490	E-527
E-121	E-158	E-195	E-232	E-269	E-306	E-343	E-380	E-417	E-454	E-491	E-528
E-122	E-159	E-196	E-233	E-270	E-307	E-344	E-381	E-418	E-455	E-492	E-529
E-123	E-160	E-197	E-234	E-271	E-308	E-345	E-382	E-419	E-456	E-493	E-530
E-124	E-161	E-198	E-235	E-272	E-309	E-346	E-383	E-420	E-457	E-494	E-531
E-125	E-162	E-199	E-236	E-273	E-310	E-347	E-384	E-421	E-458	E-495	E-532
E-126	E-163	E-200	E-237	E-274	E-311	E-348	E-385	E-422	E-459	E-496	E-533

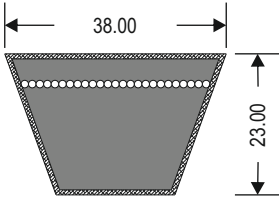

Standard : IS 2494, BS 3790, ISO 4184				
Dimensions in mm		Angle Degree	Rec. Min Pulley Dia. mm	Manufacturing Range
Top Width	Thickness			
38	23	40	500	90 to 598 inch

Nominal Length (Inches) : Inside Length (Li)

E-534	E-539	E-544	E-549	E-554	E-559	E-564	E-569	E-574	E-579	E-584	E-589
E-535	E-540	E-545	E-550	E-555	E-560	E-565	E-570	E-575	E-580	E-585	E-590
E-536	E-541	E-546	E-551	E-556	E-561	E-566	E-571	E-576	E-581	E-586	
E-537	E-542	E-547	E-552	E-557	E-562	E-567	E-572	E-577	E-582	E-587	
E-538	E-543	E-548	E-553	E-558	E-563	E-568	E-573	E-578	E-583	E-588	

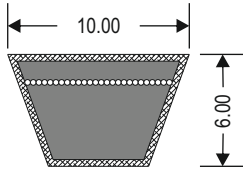

Standard : RMP IP 23				
Dimensions in mm		Angle Degree	Rec. Min Pulley Dia. mm	Manufacturing Range
Top Width	Thickness			
10	6	40	50	As given below

Nominal Length (Inches) : Outside Length (La)

FHP-2090	FHP-2160	FHP-2210	FHP-2270	FHP-2325	FHP-2355	FHP-2410	FHP-2475	FHP-2530
FHP-2100	FHP-2150	FHP-2220	FHP-2280	FHP-2330	FHP-2360	FHP-2420	FHP-2480	FHP-2540
FHP-2110	FHP-2170	FHP-2230	FHP-2290	FHP-2335	FHP-2370	FHP-2430	FHP-2490	FHP-2550
FHP-2120	FHP-2180	FHP-2240	FHP-2300	FHP-2340	FHP-2380	FHP-2440	FHP-2500	FHP-2560
FHP-2130	FHP-2190	FHP-2250	FHP-2310	FHP-2345	FHP-2390	FHP-2450	FHP-2510	
FHP-2140	FHP-2200	FHP-2260	FHP-2320	FHP-2350	FHP-2400	FHP-2460	FHP-2520	

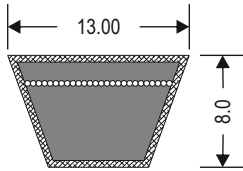

Dimensions in mm		Angle Degree	Rec. Min Pulley Dia. mm	Manufacturing Range
Top Width	Thickness			
13	8	40	71	16" to 450"

LSA - 060	LSA - 069	LSA - 078	LSA - 087	LSA - 096	LSA - 105	LSA - 114	LSA - 123	LSA - 132	LSA - 141
LSA - 061	LSA - 070	LSA - 079	LSA - 088	LSA - 097	LSA - 106	LSA - 115	LSA - 124	LSA - 133	LSA - 142
LSA - 062	LSA - 071	LSA - 080	LSA - 089	LSA - 098	LSA - 107	LSA - 116	LSA - 125	LSA - 134	LSA - 143
LSA - 063	LSA - 072	LSA - 081	LSA - 090	LSA - 099	LSA - 108	LSA - 117	LSA - 126	LSA - 135	LSA - 144
LSA - 064	LSA - 073	LSA - 082	LSA - 091	LSA - 100	LSA - 109	LSA - 118	LSA - 127	LSA - 136	
LSA - 065	LSA - 074	LSA - 083	LSA - 092	LSA - 101	LSA - 110	LSA - 119	LSA - 128	LSA - 137	
LSA - 066	LSA - 075	LSA - 084	LSA - 093	LSA - 102	LSA - 111	LSA - 120	LSA - 129	LSA - 138	
LSA - 067	LSA - 076	LSA - 085	LSA - 094	LSA - 103	LSA - 112	LSA - 121	LSA - 130	LSA - 139	
LSA - 068	LSA - 077	LSA - 086	LSA - 095	LSA - 104	LSA - 113	LSA - 122	LSA - 131	LSA - 140	

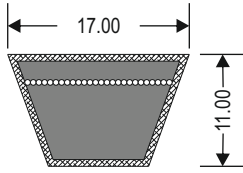

Dimensions in mm		Angle Degree	Rec. Min Pulley Dia. mm	Manufacturing Range
Top Width	Thickness			
17	11	40	112	19" to 598"

LSB - 051	LSB - 060	LSB - 069	LSB - 078	LSB - 087	LSB - 096	LSB - 105	LSB - 114	LSB - 123	
LSB - 052	LSB - 061	LSB - 070	LSB - 079	LSB - 088	LSB - 097	LSB - 106	LSB - 115	LSB - 124	
LSB - 053	LSB - 062	LSB - 071	LSB - 080	LSB - 089	LSB - 098	LSB - 107	LSB - 116	LSB - 125	
LSB - 054	LSB - 063	LSB - 072	LSB - 081	LSB - 090	LSB - 099	LSB - 108	LSB - 117	LSB - 128	
LSB - 055	LSB - 064	LSB - 073	LSB - 082	LSB - 091	LSB - 100	LSB - 109	LSB - 118	LSB - 129	
LSB - 056	LSB - 065	LSB - 074	LSB - 083	LSB - 092	LSB - 101	LSB - 110	LSB - 119	LSB - 130	
LSB - 057	LSB - 066	LSB - 075	LSB - 084	LSB - 093	LSB - 102	LSB - 111	LSB - 120	LSB - 132	
LSB - 058	LSB - 067	LSB - 076	LSB - 085	LSB - 094	LSB - 103	LSB - 112	LSA - 121	LSB - 134	
LSB - 059	LSB - 068	LSB - 077	LSB - 086	LSB - 095	LSB - 104	LSB - 113	LSB - 122	LSB - 145	

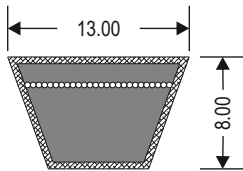

Dimensions in mm		Angle Degree	Rec. Min Pulley Dia. mm	Manufacturing Range
Top Width	Thickness			
13	8	40	71	16" to 450"

WGA - 26	WGA - 35	WGA - 44	WGA - 53
WGA - 27	WGA - 36	WGA - 45	WGA - 54
WGA - 28	WGA - 37	WGA - 46	WGA - 55
WGA - 29	WGA - 38	WGA - 47	WGA - 56
WGA - 30	WGA - 39	WGA - 48	WGA - 57
WGA - 31	WGA - 40	WGA - 49	WGA - 58
WGA - 32	WGA - 41	WGA - 50	WGA - 59
WGA - 33	WGA - 42	WGA - 51	WGA - 60
WGA - 34	WGA - 43	WGA - 52	

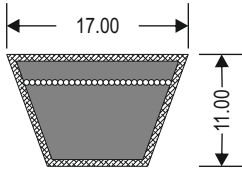

Dimensions in mm		Angle Degree	Rec. Min Pulley Dia. mm	Manufacturing Range
Top Width	Thickness			
17	11	40	112	19" to 598"

WGB - 24	WGB - 32	WGB - 40	WGB - 48	WGB - 56
WGB - 25	WGB - 33	WGB - 41	WGB - 49	WGB - 57
WGB - 26	WGB - 34	WGB - 42	WGB - 50	WGB - 58
WGB - 27	WGB - 35	WGB - 43	WGB - 51	WGB - 59
WGB - 28	WGB - 36	WGB - 44	WGB - 52	WGB - 60
WGB - 29	WGB - 37	WGB - 45	WGB - 53	
WGB - 30	WGB - 38	WGB - 46	WGB - 54	
WGB - 31	WGB - 39	WGB - 47	WGB - 55	

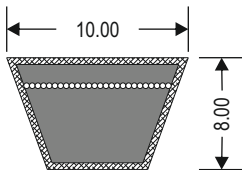

Standard : IS 14261, BS 3790				
Dimensions in mm		Angle Degree	Rec. Min Pulley Dia. mm	Manufacturing Range
Top Width	Thickness			
10	8	40	63	630 to 4500

Nominal Length (mm) : Pitch Length (Lp)

SPZ-630	SPZ-825	SPZ-1050	SPZ-1200	SPZ-1400	SPZ-1650	SPZ-2160	SPZ-2680	SPZ-3960
SPZ-637	SPZ-850	SPZ-1060	SPZ-1250	SPZ-1420	SPZ-1700	SPZ-2240	SPZ-2800	SPZ-4060
SPZ-680	SPZ-875	SPZ-1070	SPZ-1280	SPZ-1470	SPZ-1800	SPZ-2280	SPZ-2840	SPZ-4250
SPZ-690	SPZ-900	SPZ-1080	SPZ-1300	SPZ-1500	SPZ-1850	SPZ-2360	SPZ-3000	SPZ-4300
SPZ-710	SPZ-950	SPZ-1100	SPZ-1320	SPZ-1520	SPZ-1900	SPZ-2410	SPZ-3150	SPZ-4350
SPZ-750	SPZ-975	SPZ-1120	SPZ-1340	SPZ-1550	SPZ-2000	SPZ-2500	SPZ-3170	SPZ-4400
SPZ-800	SPZ-1000	SPZ-1140	SPZ-1348	SPZ-1560	SPZ-2030	SPZ-2540	SPZ-3350	SPZ-4450
SPZ-812	SPZ-1010	SPZ-1187	SPZ-1358	SPZ-1600	SPZ-2120	SPZ-2650	SPZ-3550	SPZ-4500

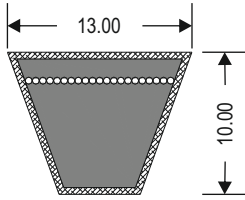

Standard : IS 14261, BS 3790

Dimensions in mm		Angle Degree	Rec. Min Pulley Dia. mm	Manufacturing Range
Top Width	Thickness			
13	10	40	90	630 to 5000

Nominal Length (mm) : Pitch Length (Lp)

SPA-630	SPA-950	SPA-1140	SPA-1320	SPA-1650	SPA-2000	SPA-2430	SPA-3150	SPA-8763
SPA-710	SPA-975	SPA-1150	SPA-1360	SPA-1700	SPA-2060	SPA-2500	SPA-3350	SPA-8800
SPA-725	SPA-1000	SPA-1180	SPA-1400	SPA-1750	SPA-2120	SPA-2580	SPA-3550	SPA-8825
SPA-800	SPA-1050	SPA-1200	SPA-1450	SPA-1800	SPA-2180	SPA-2650	SPA-3750	SPA-8850
SPA-825	SPA-1060	SPA-1220	SPA-1475	SPA-1850	SPA-2240	SPA-2720	SPA-4040	SPA-8900
SPA-850	SPA-1080	SPA-1250	SPA-1500	SPA-1900	SPA-2280	SPA-2800	SPA-4250	SPA-8925
SPA-900	SPA-1110	SPA-1280	SPA-1550	SPA-1925	SPA-2300	SPA-2900	SPA-4500	SPA-8950
SPA-925	SPA-1120	SPA-1300	SPA-1600	SPA-1950	SPA-2360	SPA-3000	SPA-8760	SPA-10000

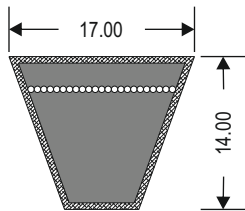

Standard : IS 14261, BS 3790

Dimensions in mm		Angle Degree	Rec. Min Pulley Dia. mm	Manufacturing Range
Top Width	Thickness			
17	14	40	140	1250 to 15000

Nominal Length (mm) : Pitch Length (Lp)

SPB-1250	SPB-1700	SPB-2280	SPB-2840	SPB-4060	SPB-5070	SPB-6700	SPB-13500
SPB-1300	SPB-1800	SPB-2360	SPB-3000	SPB-4250	SPB-5300	SPB-7100	SPB-14000
SPB-1320	SPB-1900	SPB-2410	SPB-3150	SPB-4310	SPB-5380	SPB-7500	SPB-14500
SPB-1340	SPB-2000	SPB-2500	SPB-3170	SPB-4500	SPB-5600	SPB-8000	SPB-15000
SPB-1400	SPB-2020	SPB-2530	SPB-3350	SPB-4560	SPB-5880	SPB-9000	
SPB-1500	SPB-2120	SPB-2650	SPB-3750	SPB-4750	SPB-6000	SPB-9500	
SPB-1550	SPB-2150	SPB-2680	SPB-3800	SPB-4820	SPB-6300	SPB-12500	
SPB-1600	SPB-2240	SPB-2800	SPB-4000	SPB-5000	SPB-6340	SPB-13000	

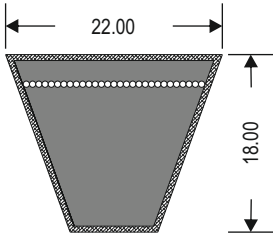

Standard : IS 14261, BS 3790				
Dimensions in mm		Angle Degree	Rec. Min Pulley Dia. mm	Manufacturing Range
Top Width	Thickness			
22	18	40	224	1400 to 15000

Nominal Length (mm) : Pitch Length (Lp)

SPC-1400	SPC-1650	SPC-1925	SPC-2650	SPC-4500	SPC-7100	SPC-11200	SPC-14500
SPC-1425	SPC-1700	SPC-1950	SPC-2800	SPC-4750	SPC-7500	SPC-11800	SPC-14750
SPC-1450	SPC-1725	SPC-2000	SPC-3000	SPC-5000	SPC-8000	SPC-12500	SPC-15000
SPC-1500	SPC-1750	SPC-2150	SPC-3350	SPC-5300	SPC-8500	SPC-12750	
SPC-1525	SPC-1800	SPC-2240	SPC-3550	SPC-5600	SPC-9000	SPC-13000	
SPC-1550	SPC-1825	SPC-2350	SPC-3750	SPC-6000	SPC-9500	SPC-13500	
SPC-1600	SPC-1850	SPC-2360	SPC-4000	SPC-6300	SPC-10000	SPC-13750	
SPC-1625	SPC-1900	SPC-2500	SPC-4250	SPC-6700	SPC-10600	SPC-14000	

NARROW SECTION

3V

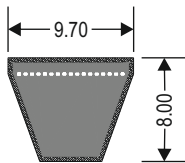

Standard : RAM IP 22				
Dimensions in mm		Angle Degree	Rec. Min Pulley Dia. mm	Manufacturing Range
Top Width	Thickness			
9.7	8	40	63	250 to 1120

Nominal Length (inches) : Belt No. / 10 = Pitch Length (La)

3V-250	3V-350	3V-470	3V-600	3V-900
3V-270	3V-360	3V-480	3V-630	3V-950
3V-280	3V-370	3V-500	3V-670	3V-1000
3V-300	3V-380	3V-510	3V-710	3V-1060
3V-315	3V-400	3V-530	3V-750	3V-1120
3V-320	3V-420	3V-560	3V-770	
3V-330	3V-450	3V-575	3V-850	

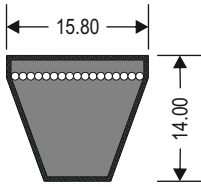

Standard : RAM IP 22				
Dimensions in mm		Angle Degree	Rec. Min Pulley Dia. mm	Manufacturing Range
Top Width	Thickness			
15.8	14	40	140	500 to 6000

Nominal Length (inches) : Belt No. / 10 = Pitch Length (La)

5V-500	5V-1120	5V-1800	5V-2650	5V-4000
5V-530	5V-1180	5V-1900	5V-2800	5V-4450
5V-750	5V-1250	5V-2000	5V-3000	5V-4750
5V-800	5V-1320	5V-2120	5V-3150	5V-5000
5V-850	5V-1400	5V-2240	5V-3350	5V-5550
5V-950	5V-1500	5V-2360	5V-3450	5V-5750
5V-1060	5V-1700	5V-2500	5V-3750	5V-6000

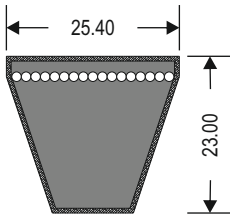

Standard : RAM IP 22				
Dimensions in mm		Angle Degree	Rec. Min Pulley Dia. mm	Manufacturing Range
Top Width	Thickness			
25.4	23	40	335	1000 to 5900

Nominal Length (inches) : Belt No. / 10 = Pitch Length (La)

8V-1000	8V-1400	8V-2120	8V-3000	8V-4750
8V-1060	8V-1500	8V-2240	8V-3150	8V-5000
8V-1120	8V-1600	8V-2360	8V-3350	8V-5900
8V-1180	8V-1700	8V-2500	8V-3550	
8V-1200	8V-1800	8V-2550	8V-3750	
8V-1250	8V-1900	8V-2650	8V-4000	
8V-1320	8V-2000	8V-2800	8V-4500	

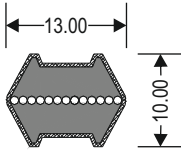

Standard : IS 11038, ISO 5289				
Dimensions in mm		Angle Degree	Rec. Min Pulley Dia. mm	Manufacturing Range
Top Width	Thickness			
13	10	40	80	75 to 250 inch

Nominal Length (inches) : Inside Length (Li)

AA-75	AA-96	AA-118	AA-136
AA-80	AA-112	AA-120	AA-250
AA-90	AA-115	AA-130	

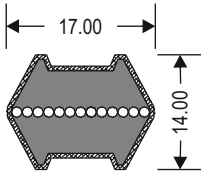

Standard : IS 11038, ISO 5289				
Dimensions in mm		Angle Degree	Rec. Min Pulley Dia. mm	Manufacturing Range
Top Width	Thickness			
17	14	40	125	75 to 350 inch

Nominal Length (inches) : Inside Length (Li)

BB-75	BB-124	BB-170	BB-180	BB-270
BB-112	BB-149	BB-174	BB-254	BB-300
BB-114	BB-166	BB-176	BB-258	BB-350

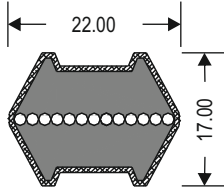

Standard : IS 11038, ISO 5289

Dimensions in mm		Angle Degree	Rec. Min Pulley Dia. mm	Manufacturing Range
Top Width	Thickness			
22	17	40	224	75 to 350 inch

Nominal Length (inches) : Inside Length (Li)

CC-75	CC-81	CC-84	CC-88	CC-94	CC-100	CC-136
CC-78	CC-82	CC-85	CC-90	CC-96	CC-115	CC-200
CC-80	CC-83	CC-86	CC-92	CC-98	CC-120	CC-350

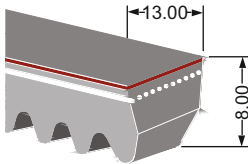

Standard : IS 2494, BS 3790

Dimensions in mm		Angle Degree	Rec. Min Pulley Dia. mm	Manufacturing Range
Top Width	Thickness			
13	8	36	63	22 to 250 inch

Nominal Length (inches) : Inside Length (Li)

AX - 22	AX - 42	AX - 62	AX - 82	AX - 102	AX - 122	AX - 142	AX - 162	AX - 182	AX - 202	AX - 222	AX - 242
AX - 23	AX - 43	AX - 63	AX - 83	AX - 103	AX - 123	AX - 143	AX - 163	AX - 183	AX - 203	AX - 223	AX - 243
AX - 24	AX - 44	AX - 64	AX - 84	AX - 104	AX - 124	AX - 144	AX - 164	AX - 184	AX - 204	AX - 224	AX - 244
AX - 25	AX - 45	AX - 65	AX - 85	AX - 105	AX - 125	AX - 145	AX - 165	AX - 185	AX - 205	AX - 225	AX - 245
AX - 26	AX - 46	AX - 66	AX - 86	AX - 106	AX - 126	AX - 146	AX - 166	AX - 186	AX - 206	AX - 226	AX - 246
AX - 27	AX - 47	AX - 67	AX - 87	AX - 107	AX - 127	AX - 147	AX - 167	AX - 187	AX - 207	AX - 227	AX - 247
AX - 28	AX - 48	AX - 68	AX - 88	AX - 108	AX - 128	AX - 148	AX - 168	AX - 188	AX - 208	AX - 228	AX - 248
AX - 29	AX - 49	AX - 69	AX - 89	AX - 109	AX - 129	AX - 149	AX - 169	AX - 189	AX - 209	AX - 229	AX - 249
AX - 30	AX - 50	AX - 70	AX - 90	AX - 110	AX - 130	AX - 150	AX - 170	AX - 190	AX - 210	AX - 230	AX - 250
AX - 31	AX - 51	AX - 71	AX - 91	AX - 111	AX - 131	AX - 151	AX - 171	AX - 191	AX - 211	AX - 231	
AX - 32	AX - 52	AX - 72	AX - 92	AX - 112	AX - 132	AX - 152	AX - 172	AX - 192	AX - 212	AX - 232	
AX - 33	AX - 53	AX - 73	AX - 93	AX - 113	AX - 133	AX - 153	AX - 173	AX - 193	AX - 213	AX - 233	
AX - 34	AX - 54	AX - 74	AX - 94	AX - 114	AX - 134	AX - 154	AX - 174	AX - 194	AX - 214	AX - 234	
AX - 35	AX - 55	AX - 75	AX - 95	AX - 115	AX - 135	AX - 155	AX - 175	AX - 195	AX - 215	AX - 235	
AX - 36	AX - 56	AX - 76	AX - 96	AX - 116	AX - 136	AX - 156	AX - 176	AX - 196	AX - 216	AX - 236	
AX - 37	AX - 57	AX - 77	AX - 97	AX - 117	AX - 137	AX - 157	AX - 177	AX - 197	AX - 217	AX - 237	
AX - 38	AX - 58	AX - 78	AX - 98	AX - 118	AX - 138	AX - 158	AX - 178	AX - 198	AX - 218	AX - 238	
AX - 39	AX - 59	AX - 79	AX - 99	AX - 119	AX - 139	AX - 159	AX - 179	AX - 199	AX - 219	AX - 239	
AX - 40	AX - 60	AX - 80	AX - 100	AX - 120	AX - 140	AX - 160	AX - 180	AX - 200	AX - 220	AX - 240	
AX - 41	AX - 61	AX - 81	AX - 101	AX - 121	AX - 141	AX - 161	AX - 181	AX - 201	AX - 221	AX - 241	

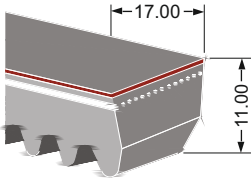

Standard : IS 2494, ISO 3790

Dimensions in mm		Angle Degree	Rec. Min Pulley Dia. mm	Manufacturing Range
Top Width	Thickness			
17	11	36	90	24 to 250 inch

Nominal Length (inches) : Inside Length (Li)

BX - 24	BX - 44	BX - 64	BX - 84	BX - 104	BX - 124	BX - 144	BX - 164	BX - 184	BX - 204	BX - 224	BX - 244
BX - 25	BX - 45	BX - 65	BX - 85	BX - 105	BX - 125	BX - 145	BX - 165	BX - 185	BX - 205	BX - 225	BX - 245
BX - 26	BX - 46	BX - 66	BX - 86	BX - 106	BX - 126	BX - 146	BX - 166	BX - 186	BX - 206	BX - 226	BX - 246
BX - 27	BX - 47	BX - 67	BX - 87	BX - 107	BX - 127	BX - 147	BX - 167	BX - 187	BX - 207	BX - 227	BX - 247
BX - 28	BX - 48	BX - 68	BX - 88	BX - 108	BX - 128	BX - 148	BX - 168	BX - 188	BX - 208	BX - 228	BX - 248
BX - 29	BX - 49	BX - 69	BX - 89	BX - 109	BX - 129	BX - 149	BX - 169	BX - 189	BX - 209	BX - 229	BX - 249
BX - 30	BX - 50	BX - 70	BX - 90	BX - 110	BX - 130	BX - 150	BX - 170	BX - 190	BX - 210	BX - 230	BX - 250
BX - 31	BX - 51	BX - 71	BX - 91	BX - 111	BX - 131	BX - 151	BX - 171	BX - 191	BX - 211	BX - 231	
BX - 32	BX - 52	BX - 72	BX - 92	BX - 112	BX - 132	BX - 152	BX - 172	BX - 192	BX - 212	BX - 232	
BX - 33	BX - 53	BX - 73	BX - 93	BX - 113	BX - 133	BX - 153	BX - 173	BX - 193	BX - 213	BX - 233	
BX - 34	BX - 54	BX - 74	BX - 94	BX - 114	BX - 134	BX - 154	BX - 174	BX - 194	BX - 214	BX - 234	
BX - 35	BX - 55	BX - 75	BX - 95	BX - 115	BX - 135	BX - 155	BX - 175	BX - 195	BX - 215	BX - 235	
BX - 36	BX - 56	BX - 76	BX - 96	BX - 116	BX - 136	BX - 156	BX - 176	BX - 196	BX - 216	BX - 236	
BX - 37	BX - 57	BX - 77	BX - 97	BX - 117	BX - 137	BX - 157	BX - 177	BX - 197	BX - 217	BX - 237	
BX - 38	BX - 58	BX - 78	BX - 98	BX - 118	BX - 138	BX - 158	BX - 178	BX - 198	BX - 218	BX - 238	
BX - 39	BX - 59	BX - 79	BX - 99	BX - 119	BX - 139	BX - 159	BX - 179	BX - 199	BX - 219	BX - 239	
BX - 40	BX - 60	BX - 80	BX - 100	BX - 120	BX - 140	BX - 160	BX - 180	BX - 200	BX - 220	BX - 240	
BX - 41	BX - 61	BX - 81	BX - 101	BX - 121	BX - 141	BX - 161	BX - 181	BX - 201	BX - 221	BX - 241	
BX - 42	BX - 62	BX - 82	BX - 102	BX - 122	BX - 142	BX - 162	BX - 182	BX - 202	BX - 222	BX - 242	
BX - 43	BX - 63	BX - 83	BX - 103	BX - 123	BX - 143	BX - 163	BX - 183	BX - 203	BX - 223	BX - 243	

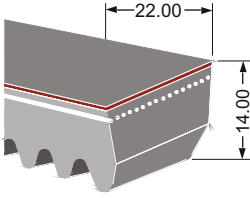

Standard : IS 2494, ISO 3790

Dimensions in mm		Angle Degree	Rec. Min Pulley Dia. mm	Manufacturing Range
Top Width	Thickness			
22	14	36	140	24 to 250 inch

Nominal Length (inches) : Inside Length (Li)

CX - 24	CX - 44	CX - 64	CX - 84	CX - 104	CX - 124	CX - 144	CX - 164	CX - 184	CX - 204	CX - 224	CX - 244
CX - 25	CX - 45	CX - 65	CX - 85	CX - 105	CX - 125	CX - 145	CX - 165	CX - 185	CX - 205	CX - 225	CX - 245
CX - 26	CX - 46	CX - 66	CX - 86	CX - 106	CX - 126	CX - 146	CX - 166	CX - 186	CX - 206	CX - 226	CX - 246
CX - 27	CX - 47	CX - 67	CX - 87	CX - 107	CX - 127	CX - 147	CX - 167	CX - 187	CX - 207	CX - 227	CX - 247
CX - 28	CX - 48	CX - 68	CX - 88	CX - 108	CX - 128	CX - 148	CX - 168	CX - 188	CX - 208	CX - 228	CX - 248
CX - 29	CX - 49	CX - 69	CX - 89	CX - 109	CX - 129	CX - 149	CX - 169	CX - 189	CX - 209	CX - 229	CX - 249
CX - 30	CX - 50	CX - 70	CX - 90	CX - 110	CX - 130	CX - 150	CX - 170	CX - 190	CX - 210	CX - 230	CX - 250
CX - 31	CX - 51	CX - 71	CX - 91	CX - 111	CX - 131	CX - 151	CX - 171	CX - 191	CX - 211	CX - 231	
CX - 32	CX - 52	CX - 72	CX - 92	CX - 112	CX - 132	CX - 152	CX - 172	CX - 192	CX - 212	CX - 232	
CX - 33	CX - 53	CX - 73	CX - 93	CX - 113	CX - 133	CX - 153	CX - 173	CX - 193	CX - 213	CX - 233	
CX - 34	CX - 54	CX - 74	CX - 94	CX - 114	CX - 134	CX - 154	CX - 174	CX - 194	CX - 214	CX - 234	
CX - 35	CX - 55	CX - 75	CX - 95	CX - 115	CX - 135	CX - 155	CX - 175	CX - 195	CX - 215	CX - 235	
CX - 36	CX - 56	CX - 76	CX - 96	CX - 116	CX - 136	CX - 156	CX - 176	CX - 196	CX - 216	CX - 236	
CX - 37	CX - 57	CX - 77	CX - 97	CX - 117	CX - 137	CX - 157	CX - 177	CX - 197	CX - 217	CX - 237	
CX - 38	CX - 58	CX - 78	CX - 98	CX - 118	CX - 138	CX - 158	CX - 178	CX - 198	CX - 218	CX - 238	
CX - 39	CX - 59	CX - 79	CX - 99	CX - 119	CX - 139	CX - 159	CX - 179	CX - 199	CX - 219	CX - 239	
CX - 40	CX - 60	CX - 80	CX - 100	CX - 120	CX - 140	CX - 160	CX - 180	CX - 200	CX - 220	CX - 240	
CX - 41	CX - 61	CX - 81	CX - 101	CX - 121	CX - 141	CX - 161	CX - 181	CX - 201	CX - 221	CX - 241	
CX - 42	CX - 62	CX - 82	CX - 102	CX - 122	CX - 142	CX - 162	CX - 182	CX - 202	CX - 222	CX - 242	
CX - 43	CX - 63	CX - 83	CX - 103	CX - 123	CX - 143	CX - 163	CX - 183	CX - 203	CX - 223	CX - 243	

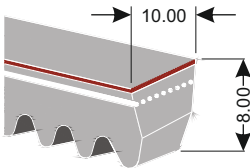

Standard : BS 3790

Dimensions in mm		Angle Degree	Rec. Min Pulley Dia. mm	Manufacturing Range
Top Width	Thickness			
10	8	36	56	600 to 4000 mm

Nominal Length (mm) : Inside Length (Lp)

XPZ - 600	XPZ - 800	XPZ - 950	XPZ - 1250	XPZ - 1500	XPZ - 1800	XPZ - 3000
XPZ - 670	XPZ - 850	XPZ - 1000	XPZ - 1320	XPZ - 1600	XPZ - 1900	XPZ - 4000
XPZ - 750	XPZ - 900	XPZ - 1120	XPZ - 1400	XPZ - 1700	XPZ - 2000	

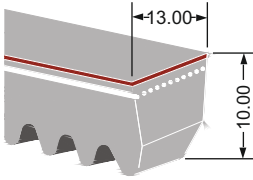

Standard : BS 3790				
Dimensions in mm		Angle Degree	Rec. Min Pulley Dia. mm	Manufacturing Range
Top Width	Thickness			
13	10	36	71	600 to 5000 mm

Nominal Length (mm) : Inside Length (Lp)

XPA - 600	XPA - 1180	XPA - 1400	XPA - 1700	XPA - 3350
XPA - 950	XPA - 1250	XPA - 1500	XPA - 1900	XPA - 5000
XPA - 1000	XPA - 1320	XPA - 1600	XPA - 2000	

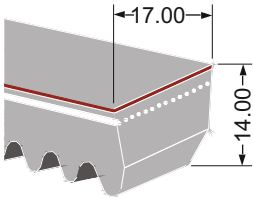

Standard : BS 3790				
Dimensions in mm		Angle Degree	Rec. Min Pulley Dia. mm	Manufacturing Range
Top Width	Thickness			
17	14	36	112	600 to 6300 mm

Nominal Length (mm) : Inside Length (Lp)

XPB - 600	XPB - 2240	XPB - 2650	XPB - 3350	XPB - 4000
XPB - 2000	XPB - 2360	XPB - 2800	XPB - 3550	XPB - 4500
XPB - 2120	XPB - 2500	XPB - 3000	XPB - 3750	XPB - 6300

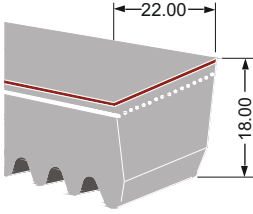

Standard : BS 3790				
Dimensions in mm		Angle Degree	Rec. Min Pulley Dia. mm	Manufacturing Range
Top Width	Thickness			
22	18	36	180	600 to 6300 mm

Nominal Length (mm) : Inside Length (Lp)

XPC - 600	XPC - 2000	XPC - 2360	XPC - 3000	XPC - 3500	XPC - 4000	XPC - 5000
XPC - 1000	XPC - 2120	XPC - 2650	XPC - 3350	XPC - 3550	XPC - 4500	
XPC - 1500	XPC - 2240	XPC - 2800	XPC - 3435	XPC - 3750	XPC - 4750	

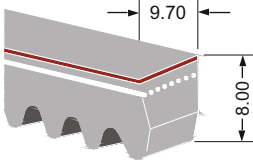

Standard : RMA IP 22				
Dimensions in mm		Angle Degree	Rec. Min Pulley Dia. mm	Manufacturing Range
Top Width	Thickness			
9.7	8	38	56	24 to 250 inch

Nominal Length (inches) : Belt No. / 10 = Inside Length (La)

3VX - 240	3VX - 630	3VX - 900	3VX - 1080	3VX - 1250	3VX - 2050	3VX - 2375
3VX - 250	3VX - 700	3VX - 950	3VX - 1120	3VX - 1320	3VX - 2075	3VX - 2400
3VX - 400	3VX - 710	3VX - 1000	3VX - 1180	3VX - 1800	3VX - 2300	3VX - 2450
3VX - 500	3VX - 750	3VX - 1030	3VX - 1220	3VX - 1900	3VX - 2325	3VX - 2475
3VX - 560	3VX - 800	3VX - 1060	3VX - 1230	3VX - 2000	3VX - 2350	3VX - 2500

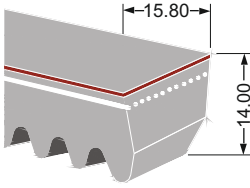

Standard : RMA IP 22				
Dimensions in mm		Angle Degree	Rec. Min Pulley Dia. mm	Manufacturing Range
Top Width	Thickness			
15.8	14	38	112	24 to 250 inch

Nominal Length (inches) : Belt No. / 10 = Outside Length (La)

5VX - 240	5VX - 500	5VX - 800	5VX - 1180	5VX - 1500	5VX - 2050	5VX - 2450
5VX - 250	5VX - 560	5VX - 1000	5VX - 1250	5VX - 1600	5VX - 2300	5VX - 2475
5VX - 350	5VX - 630	5VX - 1060	5VX - 1320	5VX - 1800	5VX - 2375	5VX - 2500
5VX - 400	5VX - 710	5VX - 1120	5VX - 1400	5VX - 2000	5VX - 2410	

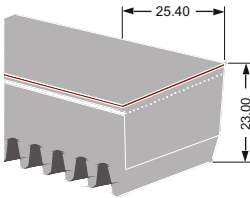

Standard : RMA IP 22				
Dimensions in mm		Angle Degree	Rec. Min Pulley Dia. mm	Manufacturing Range
Top Width	Thickness			
25.4	23	38	256	90 to 250 inch

Nominal Length (inches) : Belt No. / 10 = Inside Length (La)

8VX-900	8VX-1200	8VX-1470	8VX-1600	8VX-1860
8VX-1000	8VX-1250	8VX-1500	8VX-1700	8VX-1900
8VX-1060	8VX-1320	8VX-1530	8VX-1750	8VX-1940
8VX-1120	8VX-1400	8VX-1550	8VX-1800	8VX-1950
8VX-1180	8VX-1460	8VX-1560	8VX-1850	8VX-2000

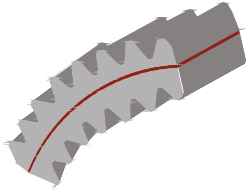

Section	Top Width mm	Thickness mm	Angle Degree	Manufacturing Range
AAX	11	10	36	75" to 200"
BBX	17	14	36	75" to 200"
CCX	22	16	36	75" to 200"

COGGED BELT **AVX 10**

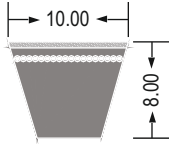

Top Width mm	Thickness mm	Manufacturing Range
10	8	500 to 3000 mm

COGGED BELT **AVX 13**

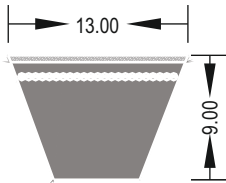

Top Width mm	Thickness mm	Manufacturing Range
13	9	500 to 3000 mm

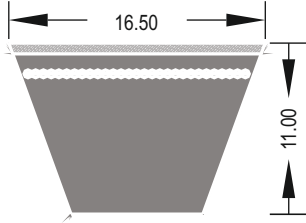

Top Width mm	Thickness mm	Manufacturing Range
16.5	11	500 to 3000 mm

## VARIABLE SPEED COGGED BELT

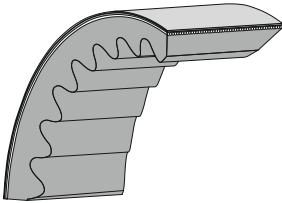

Available in the following dimensions :-  
 Length Li / Equivalent Lp / La : 24 - 200 inches  
 Top Width : 5 - 82 mm  
 Thickness : 5 - 30 mm  
 Angle : 22<sup>o</sup> 60<sup>o</sup>

## RAW EDGE MOULDED COGGED BANDED BELT

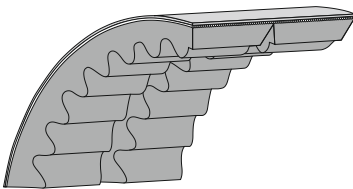

Section	Dimensions		Manufacturing Range	
	Tw (mm)	Th (mm)	Min (inch)	Max (inch)
HAX	13.0	10.0	24"	150"
HBX	17.0	13.0	24"	150"
HCX	22.0	16.0	40"	150"
HXPZ	10.0	10.0	600 mm	3500 mm
HXPA	13.0	12.0	600 mm	3500 mm
HXPB	17.0	16.0	600 mm	3500 mm
H3VX	9.7	10.0	24"	150"
H5VX	15.8	16.0	24"	150"

## WRAP CONSTRUCTION BANDED BELT

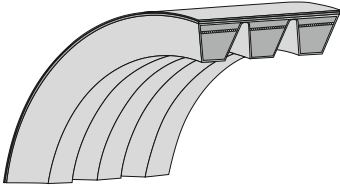

Section	Dimensions		Manufacturing Range	
	Tw (mm)	Th (mm)	Min (inch)	Max (inch)
HA	13.0	10.0	50"	110"
HB	17.0	13.0	75"	350"
HC	22.0	16.0	75"	350"
HSPB	17.0	16.0	1900 mm	8000 mm
H3V	9.7	10.0	50"	110"
H5V	15.8	16.0	75"	600"

## HEAVY DUTY BELT (HD)



Product Range : All Section

## FIRE RESISTANCE ANTISTATIC BELT (FRAS)



Product Range : All Section



Product Range : All Section

HARVESTOR COMBINE BELT & FLAT BELTS

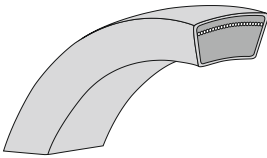

As per size requirement.

CONICAL BELT (PROFILE TOP BELT) - PT6

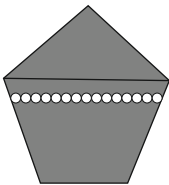

Product Range :  
B (17 x 22)  
B (17 x 21)  
C (22 x 25)

# POLY V-BELTS

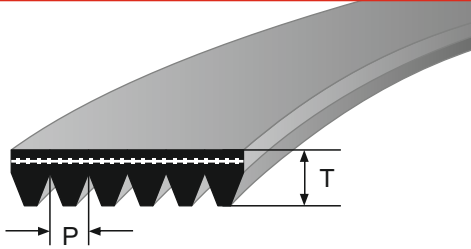

Section	Pitch (P) mm	Thickness (T) mm	Max. No. of Ribs / Sleeve
<b>PJ</b>	2.34	3.80	40

PJ 610	PJ 1092	PJ 1372	PJ 1956
PJ 660	PJ 1105	PJ 1397	PJ 1969
PJ 711	PJ 1118	PJ 1422	PJ 1994
PJ 724	PJ 1130	PJ 1473	PJ 2083
PJ 762	PJ 1143	PJ 1549	PJ 2210
PJ 813	PJ 1168	PJ 1588	PJ 2261
PJ 864	PJ 1194	PJ 1651	PJ 2388
PJ 914	PJ 1232	PJ 1664	PJ 2438
PJ 940	PJ 1270	PJ 1753	PJ 2489
PJ 965	PJ 1295	PJ 1854	PJ 2540
PJ 1016	PJ 1308	PJ 1892	
PJ 1054	PJ 1346	PJ 1905	

Section	Pitch (P) mm	Thickness (T) mm	Max. No. of Ribs / Sleeve
<b>PK</b>	3.56	4.50	24

PK 610	PK 940	PK 1359	PK 2080
PK 660	PK 991	PK 1370	PK 2164
PK 690	PK 1050	PK 1460	PK 2680
PK 699	PK 1080	PK 1626	PK 2845
PK 711	PK 1130	PK 1820	PK 2896
PK 902	PK 1257	PK 1930	PK 2921
PK 927	PK 1300	PK 1980	PK 2997

Section	Pitch (P) mm	Thickness (T) mm	Max. No. of Ribs / Sleeve
<b>PM</b>	9.40	13.50	10

PM 2311	PM 2692	PM 3010	PM 3531
PM 2388	PM 2832	PM 3124	PM 3734
PM 2515	PM 2921	PM 3327	PM 4089

Section	Pitch (P) mm	Thickness (T) mm	Max. No. of Ribs / Sleeve
<b>PL</b>	4.70	7.00	20

PL 953	PL 1715	PL 2235	PL 2997
PL 1270	PL 1803	PL 2324	PL 3086
PL 1334	PL 1842	PL 2362	PL 3124
PL 1372	PL 1943	PL 2477	PL 3289
PL 1397	PL 1981	PL 2515	PL 3327
PL 1422	PL 2019	PL 2705	PL 3493
PL 1473	PL 2070	PL 2743	PL 3696
PL 1562	PL 2096	PL 2845	PL 4051
PL 1613	PL 2134	PL 2896	
PL 1664	PL 2197	PL 2921	

Section	Pitch (P) mm	Thickness (T) mm	Max. No. of Ribs / Sleeve
<b>PH</b>	1.60	2.90	58

PH 2335	PH 2935	PH 3774	PH 5041
PH 2396	PH 3040	PH 4093	PH 5452
PH 2535	PH 3151	PH 4194	PH 6000
PH 2698	PH 3338	PH 4484	
PH 2847	PH 3552	PH 4668	

# ROUND V-BELTS

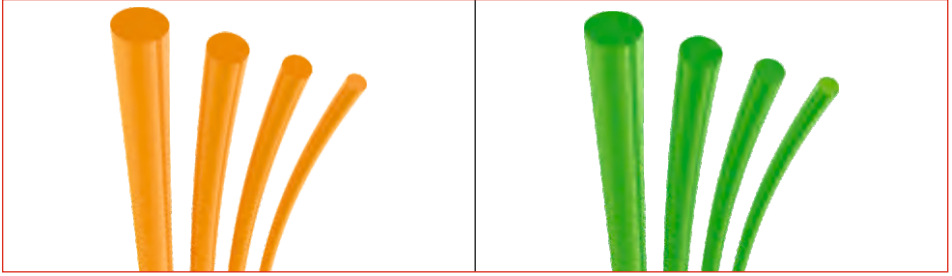

**Max Spare** has added its new range of Polyurethane Round & V Belt manufacturing and thus offers its customers a wide range in this segment. The added advantage of PU Round and V Belt is offers in endless from (Jointless) upto 1mtr. dia.

**Round Belts:** PU Round belts are available in 90° shore A hardness with rough / smooth from Diameter 2 mm to 16 mm.

**V Belts:** PU V-Belts are available in sections like M, Z, A, B, C, D, E and some special sections.

**Applications :**

Ceramic Tiles & Roof Tiles, Paper & Printing Industry, Woodworking Machines, Packaging Machines, Garment Industries, Roller Conveyors, Can Conveyors, Textile Industry, Glass Industry, Food Industry, Canneries

**PU Round Belt (Smooth Surface)**

Colour : Orange  
 Hardness : 90 A  
 Tensile strength : 5500 PSI  
 Elongation : 750% (ASTM D412)  
 Tear Strength : 680 PLI (ASTM D624)  
 Tear Abrasion : 30 mg (H18 Wheel 1000g)

**PU Round belt (Rough surface)**

Colour : Green  
 Hardness : 85 A  
 Tensile strength : 5800 PSI  
 Elongation : 790% (ASTM D412)  
 Tear Strength : 700 PLI (ASTM D624)  
 Tear Abrasion : 20 mg (H18 Wheel 1000g)

Part Type No.	Size (Dia)
PRS2	2 mm
PRS3	3 mm
PRS4	4 mm
PRS5	5 mm
PRS6	6 mm
PRS8	8 mm
PRS10	10 mm
PRS12	12 mm

Part Type No.	Size (Dia)
PRR2	2 mm
PRR3	3 mm
PRR4	4 mm
PRR5	5 mm
PRR6	6 mm
PRR8	8 mm
PRR10	10 mm
PRR12	12 mm
PRR15	15 mm



Type	Dia	Traction Rating	Elongation	Recommended pulley dia	Minimum pulley dia
8x5	M	7	5	55	50
10X6	Z	11	5	80	65
13X8	A	20	5	100	80
17X11	B	36	5	150	130
22X14	C	60	5	220	180
32X19	D	118	5	320	240

**Note :**

We can supply maximum upto 3 mtr. length or endless ring upto 1000 mm diameters on request.

# V - LOCK PULLEYS



Material : Cast Iron FG200:IS210  
Pulley Standard : IS 3142

Max Spare Part No.	Pitch Dia (MM)	Bush Size	Description	Max Spare Part No.	Pitch Dia (MM)	Bush Size	Description
VP02A0100M	100	1610	2A/SPA x 100MM	VP03A0100M	100	1610	3A/SPA x 100MM
VP02A0106M	106	1610	2A/SPA x 106MM	VP03A0106M	106	1610	3A/SPA x 106MM
VP02A0112M	112	1610	2A/SPA x 112MM	VP03A0112M	112	2012	3A/SPA x 112MM
VP02A0118M	118	1610	2A/SPA x 118MM	VP03A0118M	118	2012	3A/SPA x 118MM
VP02A0125M	125	1610	2A/SPA x 125MM	VP03A0125M	125	2012	3A/SPA x 125MM
VP02A0132M	132	1610	2A/SPA x 132MM	VP03A0132M	132	2012	3A/SPA x 132MM
VP02A0140M	140	2012	2A/SPA x 140MM	VP03A0140M	140	2517	3A/SPA x 140MM
VP02A0150M	150	2012	2A/SPA x 150MM	VP03A0150M	150	2517	3A/SPA x 150MM
VP02A0160M	160	2012	2A/SPA x 160MM	VP03A0160M	160	2517	3A/SPA x 160MM
VP02A0170M	170	2012	2A/SPA x 170MM	VP03A0170M	170	2517	3A/SPA x 170MM
VP02A0180M	180	2012	2A/SPA x 180MM	VP03A0180M	180	2517	3A/SPA x 180MM
VP02A0190M	190	2012	2A/SPA x 190MM	VP03A0190M	190	2517	3A/SPA x 190MM
VP02A0200M	200	2517	2A/SPA x 200MM	VP03A0200M	200	2517	3A/SPA x 200MM
VP02B0100M	100	1610	2B/SPB x 100MM	VP03B0160M	160	2517	3B/SPB x 160MM
VP02B0106M	106	1610	2B/SPB x 106MM	VP03B0170M	170	2517	3B/SPB x 170MM
VP02B0112M	112	1610	2B/SPB x 112MM	VP03B0180M	180	2517	3B/SPB x 180MM
VP02B0118M	118	1610	2B/SPB x 118MM	VP03B0190M	190	2517	3B/SPB x 190MM
VP02B0125M	125	1610	2B/SPB x 125MM	VP03B0200M	200	2517	3B/SPB x 200MM
VP02B0132M	132	1610	2B/SPB x 132MM	VP03B0212M	212	2517	3B/SPB x 212MM
VP02B0140M	140	1610	2B/SPB x 140MM	VP03B0224M	224	2517	3B/SPB x 224MM
VP02B0150M	150	1610	2B/SPB x 150MM	VP03B0236M	236	2517	3B/SPB x 236MM
VP02B0160M	160	2012	2B/SPB x 160MM	VP03B0250M	250	3020	3B/SPB x 250MM
VP02B0170M	170	2012	2B/SPB x 170MM	VP04B0125M	125	2012	4B/SPB x 125MM
VP02B0180M	180	2012	2B/SPB x 180MM	VP04B0132M	132	2012	4B/SPB x 132MM
VP02B0190M	190	2517	2B/SPB x 190MM	VP03B0140M	140	2012	4B/SPB x 140MM
VP02B0200M	200	2517	2B/SPB x 200MM	VP04B0150M	150	2012	4B/SPB x 150MM
VP02B0212M	212	2517	2B/SPB x 212MM	VP04B0160M	160	2517	4B/SPB x 160MM
VP03B0100M	100	1610	3B/SPB x 100MM	VP04B0170M	170	2517	4B/SPB x 170MM
VP03B0106M	106	1610	3B/SPB x 106MM	VP04B0180M	180	2517	4B/SPB x 180MM
VP03B0112M	112	1610	3B/SPB x 112MM	VP04B0190M	190	2517	4B/SPB x 190MM
VP03B0118M	118	1610	3B/SPB x 118MM	VP03B0200M	200	3020	4B/SPB x 200MM
VP03B0125M	125	1610	3B/SPB x 125MM	VP04B0212M	212	3020	4B/SPB x 212MM
VP03B0132M	132	1610	3B/SPB x 132MM	VP04B0224M	224	3020	4B/SPB x 224MM
VP03B0140M	140	1610	3B/SPB x 140MM	VP04B0236M	236	3020	4B/SPB x 236MM
VP03B0150M	150	2012	3B/SPB x 150MM	VP04B0250M	250	3020	4B/SPB x 250MM

# V - LOCK PULLEYS



Material : Cast Iron FG200:IS210  
Pulley Standard : IS 3142

Max Spare Part No.	Pitch Dia (MM)	Bush Size	Description	Max Spare Part No.	Pitch Dia (MM)	Bush Size	Description
VP03C0200M	200	2517	3C/SPC x 200MM	VP04C0200M	200	3020	4C/SPC x 200MM
VP03C0212M	212	3020	3C/SPC x 212MM	VP04C0212M	212	3020	4C/SPC x 212MM
VP03C0224M	224	3020	3C/SPC x 224MM	VP04C0224M	224	3535	4C/SPC x 224MM
VP03C0236M	236	3020	3C/SPC x 236MM	VP04C0236M	236	3535	4C/SPC x 236MM
VP03C0250M	250	3020	3C/SPC x 250MM	VP04C0250M	250	3535	4C/SPC x 250MM
VP03C0265M	265	3535	3C/SPC x 265MM	VP04C0265M	265	3535	4C/SPC x 265MM
VP03C0280M	280	3535	3C/SPC x 280MM	VP04C0280M	280	3535	4C/SPC x 280MM
VP03C0300M	300	3535	3C/SPC x 300MM	VP04C0300M	300	3535	4C/SPC x 300MM

# V - PULLEYS



Material : Cast Iron FG200:IS210  
Pulley Standard : IS 3142

Max Spare Part No.	OD (INCH)	Description	Max Spare Part No.	OD (INCH)	Description
VP01A002I	2	1A x 2 Inch x FB-PILOT	VP03B003I	3	3B x 3 Inch x FB-PILOT
VP01A004I	4	1A x 4 Inch x FB-PILOT	VP03B004I	4	3B x 4 Inch x FB-PILOT
VP01A005I	5	1A x 5 Inch x FB-PILOT	VP03B005I	5	3B x 5 Inch x FB-PILOT
VP01A006I	6	1A x 6 Inch x FB-PILOT	VP03B006I	6	3B x 6 Inch x FB-PILOT
VP01A008I	8	1A x 8 Inch x FB-PILOT	VP03B008I	8	3B x 8 Inch x FB-PILOT
VP01A010I	10	1A x 10 Inch x FB-PILOT	VP03B010I	10	3B x 10 Inch x FB-PILOT
VP01A012I	12	1A x 12 Inch x FB-PILOT	VP03B012I	12	3B x 12 Inch x FB-PILOT
VP02A002I	2	2A x 2 Inch x FB-PILOT	VP02C004I	4	2C x 4 Inch x FB-PILOT
VP02A004I	4	2A x 4 Inch x FB-PILOT	VP02C005I	5	2C x 5 Inch x FB-PILOT
VP02A005I	5	2A x 5 Inch x FB-PILOT	VP02C006I	6	2C x 6 Inch x FB-PILOT
VP02A006I	6	2A x 6 Inch x FB-PILOT	VP02C007I	7	2C x 7 Inch x FB-PILOT
VP02A008I	8	2A x 8 Inch x FB-PILOT	VP02C008I	8	2C x 8 Inch x FB-PILOT
VP02A010I	10	2A x 10 Inch x FB-PILOT	VP02C010I	10	2C x 10 Inch x FB-PILOT
VP02A012I	12	2A x 12 Inch x FB-PILOT	VP02C012I	12	2C x 12 Inch x FB-PILOT
VP01B002I	2	1B x 2 Inch x FB-PILOT	VP03C004I	4	3C x 4 Inch x FB-PILOT
VP01B004I	4	1B x 4 Inch x FB-PILOT	VP03C005I	5	3C x 5 Inch x FB-PILOT
VP01B005I	5	1B x 5 Inch x FB-PILOT	VP03C006I	6	3C x 6 Inch x FB-PILOT
VP01B006I	6	1B x 6 Inch x FB-PILOT	VP03C007I	7	3C x 7 Inch x FB-PILOT
VP01B008I	8	1B x 8 Inch x FB-PILOT	VP03C008I	8	3C x 8 Inch x FB-PILOT
VP01B010I	10	1B x 10 Inch x FB-PILOT	VP03C010I	10	3C x 10 Inch x FB-PILOT
VP01B012I	12	1B x 12 Inch x FB-PILOT	VP03C012I	12	3C x 12 Inch x FB-PILOT
VP02B002I	2	2B x 2 Inch x FB-PILOT	VP04C004I	4	4C x 4 Inch x FB-PILOT
VP02B004I	4	2B x 4 Inch x FB-PILOT	VP04C005I	5	4C x 5 Inch x FB-PILOT
VP02B005I	5	2B x 5 Inch x FB-PILOT	VP04C006I	6	4C x 6 Inch x FB-PILOT
VP02B006I	6	2B x 6 Inch x FB-PILOT	VP04C007I	7	4C x 7 Inch x FB-PILOT
VP02B008I	8	2B x 8 Inch x FB-PILOT	VP04C008I	8	4C x 8 Inch x FB-PILOT
VP02B010I	10	2B x 10 Inch x FB-PILOT	VP04C010I	10	4C x 10 Inch x FB-PILOT
VP02B012I	12	2B x 12 Inch x FB-PILOT	VP04C012I	12	4C x 12 Inch x FB-PILOT



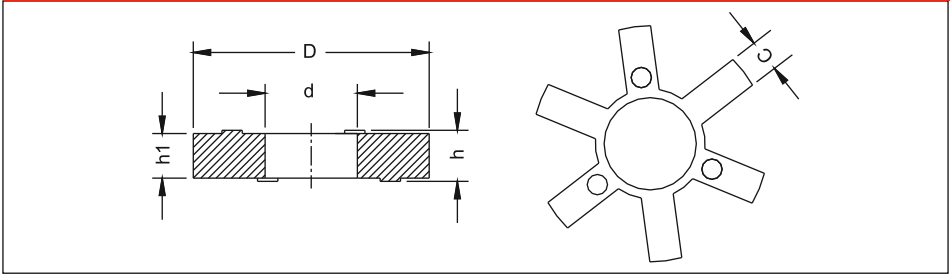

Model No. N = NBR Spider, P = PU Spider (Sizes in mm)

Model No.	N - 50	N - 70	N - 75	N - 95	N - 100	N - 110	N - 150	N - 190	N - 225
	P - 50	P - 70	P - 75	P - 95	P - 100	P - 110	P - 150	P - 190	P - 225
D	27.0	34.0	44.0	54.0	64.5	84.0	95.5	113.8	126.0
d	-	-	-	18.8	26.6	34.2	34.2	44.5	45.0
c	9.8	7.0	7.0	9.2	10.9	11.5	15.0	15.5	19.0
h	12.2	12.9	13.0	14.0	18.3	21.6	25.0	24.6	25.0
h <sub>1</sub>	10.4	11.0	11.2	11.0	15.7	18.6	21.5	21.5	22.0

## NW SERIES

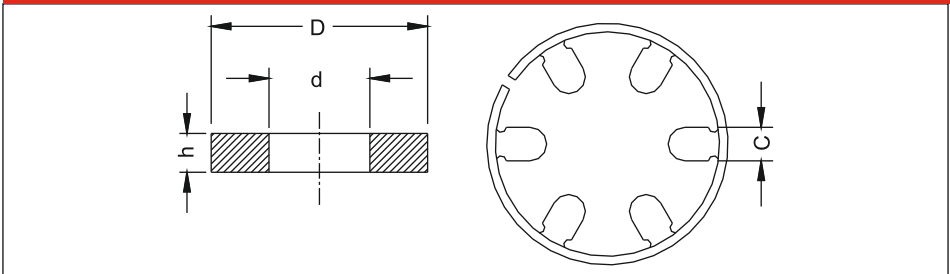

(Sizes in MM)

Model No.	d (mm)	D (mm)	c (mm)	h (mm)
NW-95	29.00	60.0	9.00	11.30
NW-100	37.00	73.5	11.00	15.70
NW-110	42.00	92.0	11.00	19.00
NW-150	45.10	106.7	15.00	21.80
NW-190	56.50	123.5	15.20	22.50
NW-225	68.70	136.7	19.00	22.00

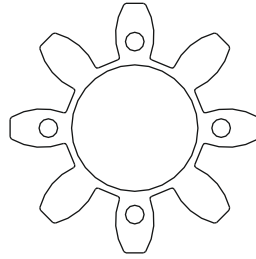
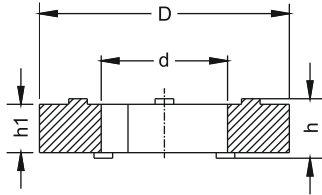

(Sizes in MM)

Model No.	d	D	h <sub>1</sub>	h	Fin Nos.
K-19	18	40	12	14.5	6
K-24	27	55	14	15.2	8
K-28	29	65	15	16.0	8
K-38	38	80	18	22.0	8
K-42	46	95	20	24.0	8
K-48	51	105	21	26.0	8
K-55	60	120	22	27.0	8
K-65	68	135	26	32.0	8
K-75	80	160	30	37.0	10
K-90	100	200	34	38.0	10

# H SERIES

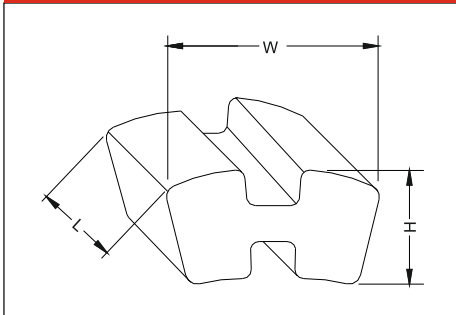

(Sizes in MM)

Model No.	L	W	H
H-80	9.0	21.0	11.0
H-95	12.2	25.0	13.2
H-110	16.0	29.0	13.5
H-125	18.2	32.0	15.0
H-140	21.5	35.0	16.0
H-160	24.5	36.5	20.3
H-180	35.0	44.0	31.5
H-200	43.5	48.0	35.5
H-240	48.0	61.0	40.0
H-280	40.0	51.0	34.5
H-315	41.0	48.0	35.6

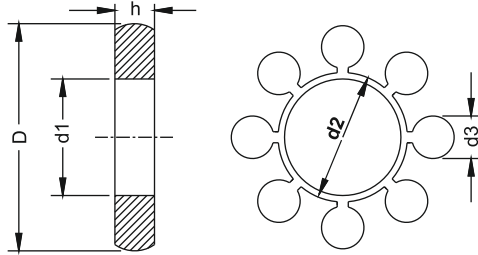

(Sizes in MM)

Model No.	D	d1	d2	d3	h	Fin Nos.
M-2	68	28	36	20	18	6
M-3	82	34	44	22	18	6
M-4	100	42	54	28	20	6
M-5	122	52	65	32	25	6
M-6	140	64	78	36	30	6
M-7	166	90	105	36	30	8
M-8	196	100	117	40	35	8
M-9	225	115	135	45	35	10

# T SERIES

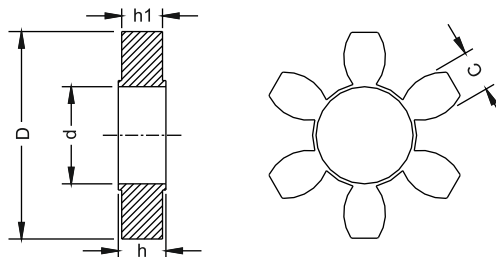

(Sizes in MM)

Model No.	D	d	c	h	h <sub>1</sub>
T-70	58.3	29.6	12.0	16.0	12.7
T-90	72.4	31.2	15.4	22.0	18.0
T-110	96.0	44.0	19.6	27.7	22.0
T-130	115.3	49.4	22.0	35.0	30.0
T-150	133.0	62.0	28.0	39.7	33.3
T-180	160.0	76.0	32.0	46.0	39.3
T-230	201.0	98.0	42.2	57.5	49.0
T-280	252.0	119.0	50.4	73.2	64.0

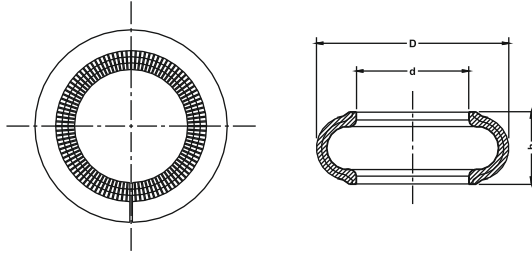

(Sizes in MM)

Model No.	d	D	h
TY-4	60.00	104.00	38.00
TY-5	70.00	133.00	49.50
TY-6	96.00	165.00	59.50
TY-7	108.00	167.00	66.50
TY-8	128.00	210.00	76.50
TY-9	146.00	235.00	80.50
TY-10	170.00	254.00	88.00
TY-11	182.00	279.00	81.00
TY-12	208.00	314.00	92.00

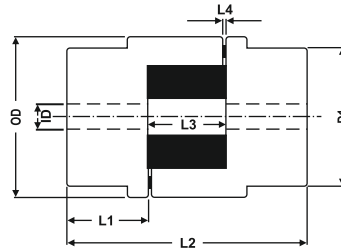

**Introduction :**

Max Spare introduces C.I. Couplings in its wide range of products. These couplings are stocks bore and used in different industries for light, medium & heavy duty electrical motor and internal combustive power transmission application. Please refer below dimensional table for more details.

**Features :**

- Easy and Fast Installation, Easy Alignment
- Best Quality cast iron body.
- Extra strength and durability
- Safety - Still perform if elastomer fails.
- Prevent metal to metal contact
- Most types available in stock within 24 hrs.

**Dimensional Information :**

**Material :** Cast Iron

Model No.	L1	L2	L3	L4	D1	ID	OD	Spider
CN-50	15.0	42.0	12.0	1.0	27.0	5.0	27.0	RUBBER
CP-50								PU
CN-70	19.0	51.0	13.0	2.0	36.0	9.0	34.5	RUBBER
CP-70								PU
CN-75	21.0	55.0	14.0	2.0	39.0	9.0	44.5	RUBBER
CP-75								PU
CN-95	25.0	63.0	13.0	2.0	49.0	10.0	54.0	RUBBER
CP-95								PU
CN-100	35.0	88.0	17.0	3.0	56.0	10.0	65.0	RUBBER
CP-100								PU
CN-110	43.0	108.0	22.0	3.0	76.0	15.0	85.0	RUBBER
CP-110								PU
CN-150	45.0	115.0	25.0	3.0	80.0	15.0	96.0	RUBBER
CP-150								PU
CN-190	54.0	133.0	25.0	3.0	102.0	20.0	115.0	RUBBER
CP-190								PU
CN-225	64.0	153.0	25.0	3.0	108.0	20.0	127.0	RUBBER
CP-225								PU

- Applications include power transmission to industrial equipment such as pumps, gear boxes, compressors, blowers, mixers & conveyors.
- Standard CP & CN couplings hub is made of cast iron.
- Readily available in stock.

**Notes :**

- 1) Above couplings are available with / without spiders.
- 2) Readily available couplings are with pilot bore.
- 3) Couplings can be supplied with Key-way and finished bore on request.

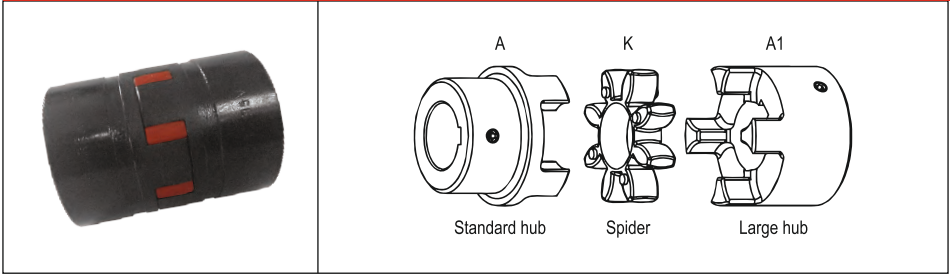

**Introduction :**

Max Spare introduces CK type couplings with Polyurethane Spiders. This curved type couplings offered in steel & casting. These couplings are used in different industries for light, medium & heavy duty electrical motor and internal combusive power transmission application.

**Features :**

- Easy and Fast Installation, Easy Alignment
- Best Quality cast iron body.
- Extra strength and durability
- Safety - Still perform if elastomer fails.
- Prevent metal to metal contact
- Most types available in stock within 24 hrs.

**Dimensional Information :**

Sizes in mm

Model No.	Hub Design	Finished Bore	D	D1;DH	L	L1;L2	E
CK - 19	A1	6 - 19	40	40	66	25	16
CK - 24	A1	9 - 24	55	55	78	30	18
CK - 28	A1	10 - 28	65	65	90	35	20
CK - 38	A	12 - 40	80	66	114	45	24
	A1	12 - 48		78			
CK - 42	A	14 - 45	95	75	126	50	26
	A1	14 - 55		94			
CK - 48	A	15 - 52	105	85	140	56	28
	A1	15 - 62		104			
CK - 55	A	20 - 60	120	98	160	65	30
	A1	20 - 74		118			
CK - 65	A	22 - 70	135	115	185	75	35
CK - 75	A	30 - 80	160	135	210	85	40

**Hub Design :**

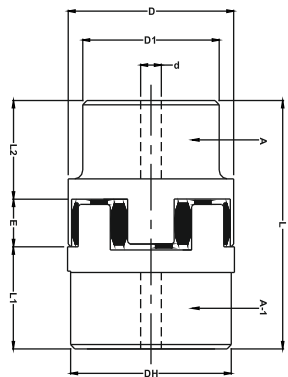

**Notes :**

- 1) Above couplings are available with / without spiders.
- 2) Readily available couplings are with pilot bore.
- 3) Couplings can be supplied with Key-way and finished bore on request.

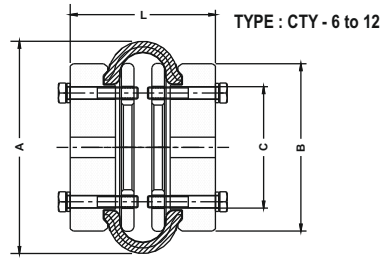
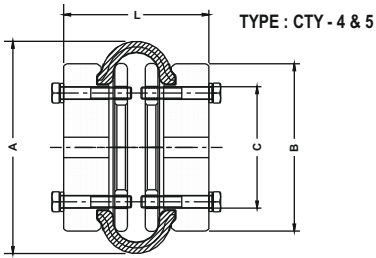

### Introduction :

Max Spare CTY Tyre Couplings are designed to absorb shocks and dampen vibrations. These couplings are highly elastic and backlash free.

### Features :

- Ease of Installation and Alignment
- Lubrication Free
- Absorb shock loadings
- Extra Strength & Durability
- Control misalignment

### Dimensional Information :

(Sizes in mm)

Model No.	A	B	C	L
CTY-4	104	82	-	68
CTY-5	133	100	79	93
CTY-6	165	125	73	111
CTY-7	197	144	82	133
CTY-8	210	167	96	149.5
CTY-9	235	188	110	165
CTY-10	254	216	125	178
CTY-11	279	233	140	183
CTY-12	314	264	152	209.5

\*Rubber element can be supplied separately on request.

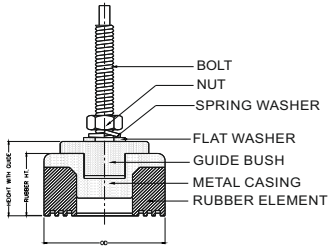

### Introduction :

Max Spare Round Mounting facility easy installation of machines, arrest noise level and vibrations. Adjustable built-up guide helps precise levelling of the machine and keeps it static. Max Spare adjustable mounting are available in 11 models to suit different load bearing capacities. Please refer below dimensional table for more details.

### Application :

Lathes, Milling, Shaping, Grinding Machines, Power & Hydraulic Presses, Notching Machines and Press Brakes, Diesel Gensets, Rolling Mills etc.

### Dimensional Information :

Model No.	OD (MM)	Height with Guide (MM)	Bush Rubber Height (MM)	Bolt Size in MM*	Load Capacity in Kg.
VM - 40	40.00	22.00	22.00	M 10 x 80	50 - 75
VM - 50	50.00	42.00	24.00	M 10 x 80	75 - 150
VM - 65	65.00	42.00	24.00	M 10 x 80	100 - 200
VM - 85	85.00	43.00	24.00	M 12 x 90	200 - 400
VM - 100	100.00	50.00	25.00	M 12 / M 16 x 90	350 - 600
VM - 125	125.00	50.00	27.00	M 12 / M 16 x 90	600 - 800
VM - 145	145.00	57.00	30.00	M 16 x 90 M 20 x 100	700 - 1200
VM - 165	165.00	57.00	30.00	M 16 x 90 M 20 x 100	850 - 1400
VM - 185	185.00	68.00	36.00	M 16 x 90 M 20 x 100	1150 - 1800
VM - 200	200.00	68.00	38.00	M 16 x 90 M 20 x 100	1550 - 2100
VM - 250	250.00	83.00	48.00	M 24 x 150	2000 - 2500

\*Optional bolt sizes can be supplied as per request.

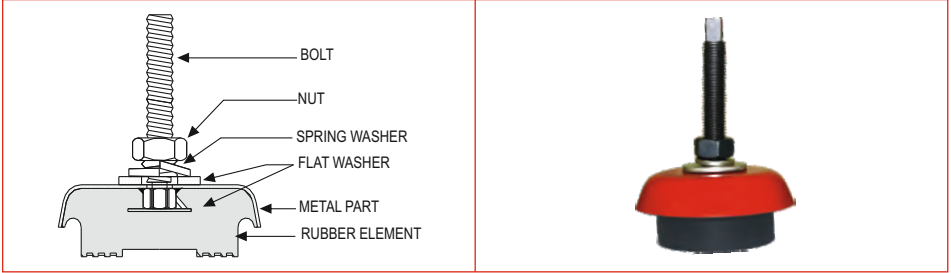

**Introduction :**

Max Spare LM Series light duty round mountings are used for light and medium duty machine foots. Easy to install machines without heavy concrete base thus make easier to shift machine and re-install.

**Features :**

- This isolates the vibration and shock of the machine from the floor
- This can also reduce the influence of other machines
- Oil resist rubber element.
- Machines are stationery on the floor without anchors

**Application :**

These mounts are suitable for Light duty industries, textiles, food processing units and Metal cutting machines.

**Dimensional Information :**

Model No.	Foot Dia (mm)	Foot Height (mm)	Bolt Size (mm)	Static Load per Mount (in Kgs.)
LM - 85	85.00	37.00	M 12 x 90	100 - 200
LM - 130	130.00	39.00	M 12 x 90	200 - 500
LM - 160	160.00	49.00	M 16 x 90	500 - 700

\*Optional bolt sizes can be supplied as per request.



## DEPTH CALIPER

### 5 Easy steps to groove measurement -

- 1) Choose the suitable pin to put in the upper of the lower hole.
- 2) Push the pin to reset the graduation to zero.
- 3) Down to gland hole to measure the depth of groove.
- 4) Measure the order side of the pin.
- 5) Depth = Length of pin - measurement.



Light Duty



Medium Duty



Heavy Duty

## O-RING HOOK

Removing 'O' Rings from the seal with steel implements poses the real danger of damaging the 'O' Ring seat. With Max Spare 'O' Ring Hooks the removal of 'O' rings is simple, and safe. The 'O' Ring hooks come in a set of 4, with different profiles. The design of the hooks is such that it does not damage the seat. Knurled handle provides firm grip.

## SEAL TWISTOR

### SIZE RANGE

SPECIFICATION	S		M		L		XL	
Ø GLAND HOLE	22 to 30mm	0.7" to 1.187"	30 to 50mm	1.187" to 2"	50 to 70mm	2" to 2.75"	70 to 165mm	2.75" to 6.5"
Cross Section Max.	5mm	0.187"	6mm	0.234"	10mm	0.375"	17.5mm	0.187"



### 5 Easy steps to install Rod Seals with Seal Twistor:



Fix the handle in the stand hole. Then put two arms inside the seal.



Twist the seal with guiding hand to prevent it from popping out.

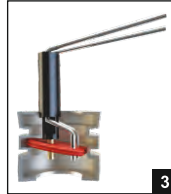

Hold the handles, then put the seal into the gland hold carefully.

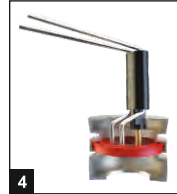

Turn handles back, then pull TWISTOR out to rebound the seal in the groove.

## PISTON SEAL CONSTRICTOR

### Step 1



Prepare a twist bar and adapter as shown in the figure. Set the twist bar and adapter as shown. Then set the Teflon ring in the center of the band.

### Step 2



Hold for 10 seconds or more.

### Step 3



Installation is completed by the above steps. The internal and external circumstances faces of the Teflon ring affect sealing performance. So be careful to scratch the ring.



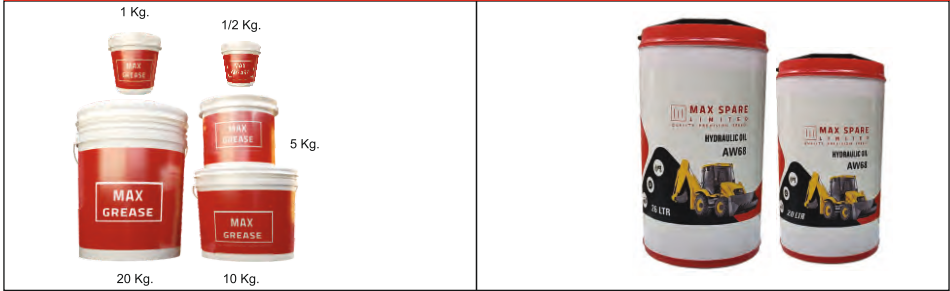

## Max Grease :

Max spare offer Lithium & Calcium based grease lubricate moving parts with excellent shear stability, anti-rust, anti-corrosion and water resistant properties

### Variants :

- Hydraulic oil :- AW32, AW46, AW68
- Cutting oil
- Rust preventive oil

## Max Oil :

Max Hydraulic oil is premium quality, anti-wear hydraulic oils intended for, industrial and mobile service applications, subjected to moderate operating conditions and requiring anti-wear lubricants. This offers outstanding hydraulic pump performance

### Variants :

- AP2, AP3
- EP2, EP3
- MP3
- CHASSIS GREASE



## Max-O-Lube

- Can be used in both High Pressure and Vacuum Systems.
- Non-toxic and non-irritating.
- Suitable for temperature range of  $-40^{\circ}\text{C}$  to  $+225^{\circ}\text{C}$
- Can be used with a variety of fluid media as it is inert.



65 G / 100 ML

300 G / 480 ML

## Max 40 Multifunctional Fluid

A multi-functional fluid, MAX-40 is versatile. Precision-penetrating and lubricating product that breaks through rust and corrosion displaces water and cleans scale and dirt. The added Dry Lubricant improves lubrication and retains it over an extended period of time.

Max-40 can be used in all working environments, for electrical parts, automotive assemblies, vehicle/aircraft maintenance, office/home machines, leisure and sporting equipment, workshops, factories and a lot more.

Note : All pictures shown are for illustration purpose only. Actual product may vary due to product enhancement.

## IR THERMOMETER

IR thermometer is a device instantly measures temperature from a distance without contact with the object to be measured.

### Features:

- » °C or °F Selection
- » Laser Target Pointer Selection
- » Automatic Data Hold Function
- » Auto Power Off
- » Adjustable Emissivity

### Technical Data:

Temperature Range	-50°C to 550°C (-58°F to 1022°F)
Accuracy	-50°C ~ 0°C / -58°F ~ 32°F ; ± 4°C / 7.2°F 0°C ~ 550°C / 32°F ~ 1022°F ; ± 2% (± 2°C / 3.6°F)
Emissivity	Adjustable 0.1~1.0
Distance Spot Ratio	12:1



Distance to spot Ratio - 12:1

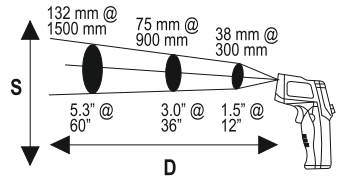

## CONTACT TACHOMETER - Model: DT-2235B

DT-2235 is Contact type Tachometer to measure the RPM.

### Product Details:

Model	DT-2235B
Range	0.5 to 19,999 RPM
Surface Speed	0.05 to 1,999.9 m/min. (0.2 to 6,560 ft/min)
Resolution	RPM 0.1 RPM < 1,000 1 RPM 1,000 RPM
Display	5 digits, 10 mm (0.4") LCD.
Sampling Time	1 second (6 RPM)
Circuit	Exclusive one-chip of micro LSI circuit.
Battery	1.5 V AA (UM-3) battery x 4 PCs.
Operating Temp	0 to 50 ? (32 to 122 ?)
Memory	Last value, Max. value, Min. value.
Size	208 x 72 x 37 mm (8.2 x 2.8 x 1.5 inch).
Weight	280g (0.62 LB)/including battery.



Note : All pictures shown are for illustration purpose only. Actual product may vary due to product enhancement.

## SEAL MAINTENANCE TOOL BOX

Max Spare offers, Seal Maintenance Tool Box easy for seal installations, removal or checking purpose accessories.

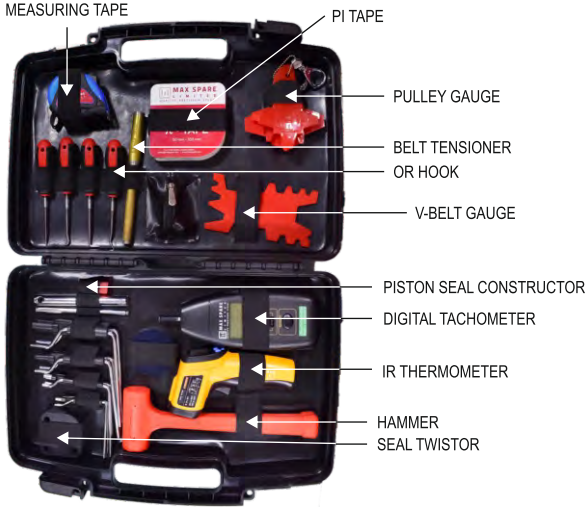

## CIRCUMETER

Circometer (Pi Tape) is very useful for accurate measurement for flexible rubber item such as O-Rings. Max Spare offer 3 ranges of Pi tape which covers diameter from 50 mm to 1400 mm.

Size Range
50 - 300 mm
100 - 700 mm
200 - 1400 mm



Note: Order your require size Pi tape on [www.maxspare.com](http://www.maxspare.com)

Note : All pictures shown are for illustration purpose only. Actual product may vary due to product enhancement.

Standard Sheets



Preformed Customised Shapes



Max Spare offers Felt Sheets used in different industrial application such as packing, padding, cushioning, wiping, wicking, lubricating, sealing etc. These sheets are available in various sizes and thickness. Also can be supplied in Ring form or Customised preformed shape and strips.

**Features :**

- Durable
- Water Proof
- Light Weight
- Eco-friendly

Sheet Form		
Length (mtr)	Width (mtr)	Thk. (mm)
2	1	3
2	1	4
2	1	5
2	1	6
2	1	8
2	1	10
2	1	12
2	1	16
2	1	20
2	1	25

Ring Form		
ID (mm)	OD (mm)	Thk. (mm)
50	70	10
55	75	10
60	80	10
65	85	10
70	90	10
75	105	15
80	110	15
85	115	15
90	120	15
100	140	20
105	145	20
110	150	20
115	155	20

Ring Form		
ID (mm)	OD (mm)	Thk. (mm)
120	160	20
125	165	20
130	170	20
135	175	20
140	180	20
145	185	20
150	200	25
160	210	25
170	220	25
180	230	25
190	240	25
200	250	25



Gaskets play an important role in the prevention of fluid leakage from pipes and equipment parts, in a wide range of fields such as petroleum refining, chemical industry, shipping, construction, electric power, and steelmaking.

Material	Size & Profile	Thickness
NBR Aramid Fiber	As Per Requirement	1, 2, 3 mm
NBR Fabric	As Per Requirement	1 TO 6 mm
Neoprene fabric	As Per Requirement	1 TO 6 mm
NBR	As Per Requirement	1 TO 6 mm
Neoprene ( CR )	As Per Requirement	1 TO 6 mm
Natural Rubber	As Per Requirement	1 TO 6 mm
Silicon	As Per Requirement	1 TO 6 mm
FKM	As Per Requirement	1 TO 6 mm
SBR	As Per Requirement	1 TO 6 mm
EPDM	As Per Requirement	1 TO 6 mm
Virgin PTFE	As Per Requirement	1, 2, 3, 4 mm
Carbon Filled PTFE	As Per Requirement	1, 2, 3, 4 mm
Glass Filled PTFE	As Per Requirement	1, 2, 3, 4 mm
Polymer Filled PTFE	As Per Requirement	1, 2, 3, 4 mm
Polyurethane	As Per Requirement	1, 1.5, 2, 2.5, 3, 4 mm
Felt	As Per Requirement	3, 4, 5, 6, 8, 10, 12, 16, 20 & 25 mm

\*Other materials available on request



PTFE Packing



PTFE Packing



Graphite Packing



PTFE / Graphite Packing

Max Spare offers compression gland packings which are designed and constructed using latest design technology and the most advanced processes with the highest quality braiding methods. Max Spare packings offers superior sealing performance, long packing life and the ability to be used in wide range of applications. These Packings are cost effective and have the ability to replace any leading manufactures in the market.

Our range in this Gland Packings are

1. Pure PTFE Packing
2. Pure Flexible Expanded Graphite Packing

**Pure PTFE Packings :**

Pure PTFE Packings is square braided packing constructed from PTFE yarns and impregnated with PTFE dispersion and further heavily lubricated and saturated with an inert lubricant. It is suitable for Food, Pharmaceutical and Chemical industries.

**Pure Flexible Expanded Graphite Packing :**

Pure Flexible Expanded Non-Metallic Graphite Packing is constructed from pure expanded graphite yarn with excellent carbon content. Being pure graphite, they have excellent chemical resistance, and can be used in extreme temperature and pressure conditions. It is suitable for sealing critical applications in valves and pumps Industries.

Sizes		
C/S		Thk.
6.5	x	6.5
8	x	8
10	x	10
12.5	x	12.5
16	x	16
19	x	19
22	x	22
25	x	25

**Note:**

Length as per requirement.

We can supply in Ring form also on request.

## MR1 - OP

**Material:**

Casing : SS 304  
 Spring : SS 304  
 Rubber Bellow : NBR 70<sup>o</sup> Shore A  
 Rotary Face : Carbon  
 Stationary Face : Ceramic

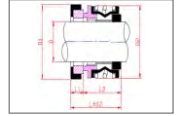

Part No.	Model	d	D1	D2	L1	L2	L
MR10160701	MR1	16.00	30.30	30.00	7.50	16.00	23.50
MR10190701	MR1	19.00	35.00	34.00	9.70	17.00	26.70
MR10200701	MR1	20.00	38.30	36.00	9.40	17.00	26.40
MR10250701	MR1	25.00	42.40	42.60	9.70	20.00	29.70

## MR2 - CL

**Material:**

Casing : SS 304  
 Spring : SS 304  
 Rubber Bellow : NBR 70<sup>o</sup> Shore A  
 Rotary Face : Carbon  
 Stationary Face : Ceramic

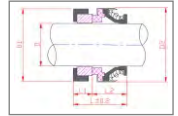

Part No.	Model	d	D1	D2	L1	L2	L
MR20160701CL	MR2-CL	16.00	32.00	28.50	10.00	11.00	21.00
MR20160704CL	MR2-CL	16.00	38.50	35.00	17.00	8.00	25.00
MR20190701CL	MR2-CL	19.00	36.70	35.00	17.00	8.00	25.00
MR20200701CL	MR2-CL	20.00	38.00	35.00	9.50	14.00	23.50

## MR2 - ST

**Material:**

Casing : SS 304  
 Spring : SS 304  
 Rubber Bellow : NBR 70<sup>o</sup> Shore A  
 Rotary Face : Carbon  
 Stationary Face : Ceramic

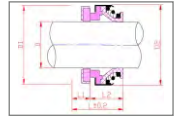

Part No.	Model	d	D1	D2	L1	L2	L
MR20250701ST	MR2-ST	25.00	42.00	42.00	10.70	14.00	24.70
MR20250702ST	MR2-ST	25.00	50.60	47.00	19.00	10.00	29.00

## MR4

**Material:**

Casing : SS 304  
 Spring : SS 304  
 Rubber Bellow : NBR 70<sup>o</sup> Shore A  
 Rotary Face : Carbon  
 Stationary Face : Ceramic



Part No.	Model	d	D1	D2	L1	L2	L
MR40250701	MR4	25.00	40.00	39.00	7.00	25.00	32.00

## MR6

**Material:**

Casing : SS 304  
 Spring : SS 304  
 Rubber Bellow : NBR 70<sup>o</sup> Shore A  
 Rotary Face : Carbon  
 Stationary Face : Ceramic

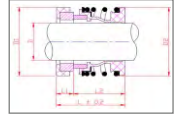

Part No.	Model	d	D1	D2	L1	L2	L
MR60160701	MR6	16.00	27.00	28.50	6.60	17.00	23.60
MR60180701	MR6	18.00	33.00	32.00	7.50	19.50	27.00
MR60250701	MR6	25.00	40.00	42.50	7.50	23.00	30.50
MR60280701	MR6	28.00	43.00	49.00	7.50	26.50	34.50

## MR7

**Material:**

Casing : SS 304  
 Spring : SS 304  
 Rubber Bellow : NBR 70<sup>o</sup> Shore A  
 Rotary Face : Carbon  
 Stationary Face : Ceramic

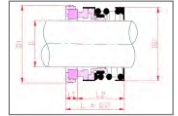

Part No.	Model	d	D1	D2	L1	L2	L
MR70160701	MR7	16.00	32.00	26.20	9.60	18.00	27.60
MR70200701	MR7	20.00	38.00	33.00	9.40	21.00	30.40
MR70250701	MR7	25.00	44.00	39.00	10.00	23.00	33.00
MR70300701	MR7	30.00	48.00	48.50	10.00	24.00	34.00
MR70320701	MR7	32.00	48.00	48.50	10.00	24.00	34.00

## MR8

**Material:**

Casing : SS 304  
 Spring : SS 304  
 Rubber Bellow : NBR 70<sup>o</sup> Shore A  
 Rotary Face : Carbon  
 Stationary Face : Ceramic



Part No.	Model	d	D1	D2	L1	L2	L
MR80160701	MR8	16.00	31.00	30.40	8.50	16.00	24.50

## MR9

**Material:**

Casing : SS 304  
 Spring : SS 304  
 Rubber Bellow : NBR 70<sup>o</sup> Shore A  
 Rotary Face : Carbon  
 Stationary Face : Ceramic



Part No.	Model	d	D1	D2	L1	L2	L
MR90150701	MR9	15.87	30.30	36.50	6.50	21.80	28.30
MR90190701	MR9	19.05	35.40	45.00	5.30	22.50	27.80

## MR10

**Material:**

Casing : SS 304  
 Spring : SS 304  
 Rubber Bellow : NBR 70<sup>o</sup> Shore A  
 Rotary Face : Carbon  
 Stationary Face : Ceramic



Part No.	Model No.	d	D1	D2	L1	L2	L
MR100120701	MR10	12.00	26.00	25.50	8.50	19.00	27.50
MR100160701	MR10	16.00	30.00	29.50	7.50	20.00	27.50
MR100180701	MR10	18.00	36.00	34.50	10.00	23.00	33.00
MR100190701	MR10	19.00	36.00	34.50	10.00	23.00	33.00

## MR11

**Material:**

Casing : SS 304  
 Spring : SS 304  
 Rubber Bellow : NBR 70<sup>o</sup> Shore A  
 Rotary Face : Carbon  
 Stationary Face : Ceramic

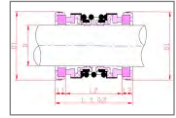

Part No.	Model No.	d	D1	D2	L1	L2	L
MR110160701	MR11	16.00	30.00	5.00	26.00	5.00	36.00
MR110200701	MR11	20.00	38.00	7.00	35.00	7.00	49.00

## MU2

**Material:**

Casing : SS 304  
 Spring : SS 304  
 Rubber Bellow : NBR 70<sup>o</sup> Shore A  
 Rotary Face : Carbon  
 Stationary Face : Ceramic

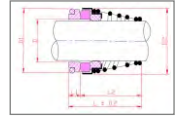

Part No.	Model No.	d	D1	D2	L1	L2	L
MU20140701	MU2	14.00	23.10	25.00	6.00	22.00	28.00
MU20160701	MU2	16.00	26.90	29.00	7.00	23.00	30.00

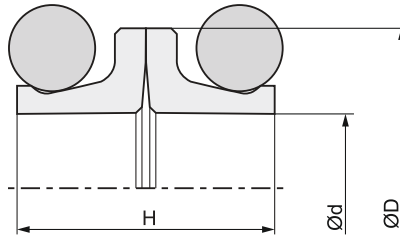

**Introduction :**

Maxspare MDO type consists of two identical metal seal rings attached face-to-face in two different housings. The metal rings are centered inside their housing by an elastomer O-Ring. One half of the mechanical face seal remains stationary in the housing while the other half rotates with its opposite face.

**MATERIALS:** High Alloy Cast Iron + NBR O Rings

**MAX OPERATING CONDITIONS:**

- Pressure: 3 BAR
- Speed: 3 m/s
- Temp. Range: -30°C to +100°C

**APPLICATION:**

Mechanical face seals are mainly used for sealing the bearings in construction machinery or production plants that work in very difficult conditions and are subject to wear. Includes -

- Heavy Trucks
- Axles
- Agriculture & Mining Machines
- Tunnel Boring Machines
- Conveyor systems
- Excavator and Bulldozers

Max Spare Part No.	d	D	H
MDO0460601	46.00	59.00	20.00
MDO0550601	55.00	70.00	22.00
MDO0600601	60.00	73.00	20.00
MDO0670601	67.50	86.50	31.80
MDO0680601	68.50	89.00	24.00
MDO0710601	71.00	84.00	20.00
MDO0710602	71.06	88.80	24.60
MDO0810601	81.00	98.00	28.00
MDO0830601	83.00	102.00	28.00
MDO0900601	90.50	104.50	26.00
MDO0960601	96.20	111.00	24.00
MDO1040601	104.00	125.00	28.00

## Storage Conditions:

Most polymers, including vulcanized rubber and other elastomers, tend to change their properties during storage and may become unusable. This may be due to hardening, softening, cracking or other deterioration and may result from exposure to oxygen, ozone, light, heat and /or moisture.

The following recommendations indicate the most suitable storage conditions for elastomeric products, whether it is a single item or a composite product.

1. **Temperature** - Ideal storage temperature should be 25°C (77°F). Low temperatures are not permanently harmful provided the rubber items are handled carefully and not distorted. When taken from low temperatures items should be raised to approximately 30°C (86°F) before they are used.
2. **Humidity** – Relative humidity is of 40% to 70% in a draft-free atmosphere.
3. **Light** – The products should be protected from direct sunlight, ultraviolet and artificial light have a high UV content.
4. **Oxygen and Ozone** - Wrapping, storage in airtight containers or other suitable means should be used for vulcanised rubber items. Storage in containers that limit exposure to environmental conditions (e.g. sealed plastic bags) should be used for all materials.
5. **Radiation** – Products should be protected from all sources of ionizing radiation.
6. **Deformation** – The rubber items should be stored in a relaxed position, without tension or compression. Laying the product on a flat surface and preventing its suspension or crushing keeps it from deforming and minimizes deformation.
7. **Contact with liquid or semi-liquid materials** – Rubber should not come in to contact with liquid or semi-liquid materials or their vapours at any time during storage, unless these materials are an integral part of the product or the manufacturer's packaging.
8. **Contact with Metals** - Metals such as manganese, iron and copper, or copper alloys can have a harmful effect on rubber. A layer of paper, polyethylene or cellophane will keep these separated.
9. **Contact with Non-Metals** - Contact with other rubbers should be avoided.
10. **Stock Rotation** - Elastomers should be stored for as short a period as possible, and practice the First In First Out (FIFO system) stock liquidation.
11. **Cleaning** - Organic solvents such as trichloroethylene, carbon tetrachloride and petroleum are the most harmful agents. Soap and water and methylated spirits are the least harmful, and all parts should be dried at room temperature before use.
12. **Shelf Life** - The table shows the storage life of seal components made from the more common materials under ideal conditions. Storing under less than ideal conditions will reduce the life of the component.

Careful inspection for the following should be made before installation after storage:

- Cracks or Surface crazing
- Mechanical damage
- Permanent distortion
- Surface softening or hardening

Rubber / Elastomer	Max Code	Primary storage period (Years)	Extension of storage period after visual re-inspection (Years)
Nitrile Butadiene Rubber (NBR)	NT	7	3
Ethylene Propylene (EPDM)	EP	10	5
Fluorocarbon (FKM)	VT	10	5
Vinyl-Methyl-Silicon (VMQ)	SL	10	5
Polyurethane (PU)	PU	5	2
Engineering Thermoplastics:			
Acetal (POM)	ACT	Unlimited	-
Polyamide (PA)	NY		
Polytetrafluoroethylene (PTFE)	PFT		

# SEALING MATERIAL

Max Spare uses raw materials of global standards procured from well known global companies such as DuPont, Lanxess, Bayer, Japan Synthetic Rubber, Huntsman etc.

## Our Global Suppliers -



## Elastomers:

Materials (Commonly known as)	Material Description	Temp. Range	Hardness (Shore A)
NITRILE	Acrylonitrile Butadiene Rubber (NBR)	-30°C to + 100°C	40A to 95A
NITRILE	Low Temp. Resistance Acrylonitrile Butadiene Rubber	-50°C to + 100°C	60A to 90A
NITRILE	High Oil Resistance Acrylonitrile Butadiene Rubber	-30°C to + 120°C	70A to 85A
XNBR	Carboxilated Nitrile Rubber (XNBR)	-30°C to + 100°C	60A to 95A
HNBR	Hydrogenated Acrylonitrile Butadiene (HNBR)	-30°C to + 150°C	60A to 95A
VITON	Fluorocarbon Rubber (FKM) / Fluoroelastomer (FKM)	-30°C to + 220°C	60A to 90A
FFKM	Perfluoro Elastomer (FFKM)	-10°C to + 300°C	70A to 75A
FEPM	AFLAS (FEPM)	-10°C to + 200°C	70A to 90A
SILICONE	Silicon Rubber (VMQ)	-60°C to + 200°C	30A to 80A
FVMQ	Fluorosilicone Rubber (FVMQ)	-70°C to + 220°C	60A to 80A
NEOPRENE	Chlorobutadiene Rubber (CR)	-40°C to + 120°C	40A to 95A
EPDM	Ethylene Propylene Diene Rubber (EPDM)	-40°C to + 120°C	50A to 95A
BUTYL	Butyl Rubber (IIR)	-40°C to + 120°C	60A to 80A
NR	Natural Rubber (NR)	-40°C to + 80°C	40A to 90A
SBR	Styrene Butadiene Rubber (SBR)	-30°C to + 100°C	40A to 90A
ACM	Polyacrylic Rubber (ACM)	-10°C to + 170°C	60A to 85A























## Fabrics:

Materials (Commonly known as)	Material Description
Cotton Fabric	Cotton Fabric
Aramide Fabric	Aramid Fabric
Kevlar Fabric	Kevlar Fabric
Nylon Fabric	Nylon Fabric

**Note:** Fabric listed can be impregnated with above elastomers as per application requirement.

For more material details and to get material data sheet, visit <https://www.maxspare.com/technical-support/sealing-materials>

## Thermoplastics & Thermosets:

Materials (Commonly known as)	Material Description	Temp. Range	Hardness (Shore A)
 PU	General Purpose / Oil Resistance PU & FDA Grade	-40°C to + 80°C	70A to 85A
 PU	General Purpose / Oil Resistance PU & FDA Grade	-40°C to + 100°C	90A to 70D
 PU - X	High Oil Resistance Polyurethane	-40°C to + 150°C	92A
 PU - W	Heat + Hydrolysis Resistance	-40°C to + 130°C	92A
 CPU - W	Hydrolysis Cast Polyurethane	-30°C to + 100°C	93A
 CPU - O	High Oil Resistance Cast Polyurethane	-30°C to + 100°C	93A
 PP	Polypropylene (PP)	-20°C to + 95°C	80M
 LLDPE	Linear Low-Density Polyethylene	-70°C to + 90°C	65M
 HDPE	High Density Polyethelone	-70°C to + 110°C	80M
 UHMWPE	Ultra-High-Molecular-Weight Polyethylene	-250°C to +80°C	65D
 PPS	Polyphenylene Sulphide	Up to 300°C	100M
 ACETAL	Polyacetal (POM)	-20°C to + 80°C	94M
 NYLON PA6	Polyamide Nylon (Unfilled)	-30°C to + 100°C	80M
 NYLON PA66	Glass Filled Polyamide (Nylon)	-40°C to + 150°C	95M
 PEEK	Polyether Ether Ketone	Up to + 280°C	99M
 HYTREL	Polyester Elastomer (TPE)	-30°C to + 100°C	90A to 72D
 PRW	Polyester Resin Fabric	-30°C to + 120°C	HRM 100
 TEFLON	Polytetrafluoroethylene (PTFE)	-250°C to + 250°C	55A to 65D
 BRT	Bronze Filled Teflon (40% & 60% Bronze Filled PTFE)	-200°C to + 260°C	62D to 73D
 GLT	Glass Filled Teflon (15% & 25% Glass filled PTFE)	-200°C to + 260°C	57D to 66D
 CAT	Carbon Filled Teflon ( 15% & 25% Carbon filled PTFE)	-200°C to + 260°C	60D to 70D
 GRT	Graphite Filled Teflon ( 15% & 25% Graphite filled PTFE)	-200°C to + 260°C	60D to 67D
 CPF	Phenolic Resin Bonded Fabric	-20°C to + 120°C	89M

For more material details and to get material data sheet,  
visit <https://www.maxspare.com/technical-support/sealing-materials>



IN TECHNICAL COLLABORATION WITH  
UKSEALS & POLYMERS LTD. (ENGLAND)

# MAX SPARE SEALS PROFILES

## Hydraulic Seals - Piston Seals

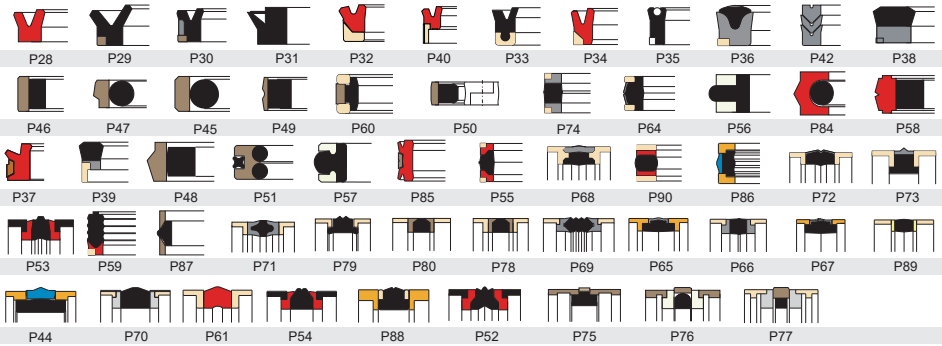

## Pneumatic Seals - Piston Seals

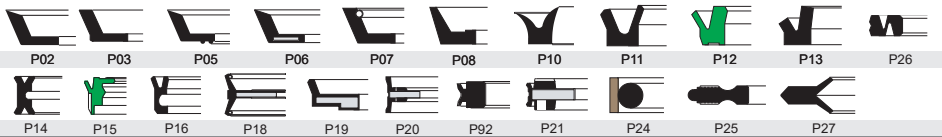

## Hydraulic Seals - Rod Seals

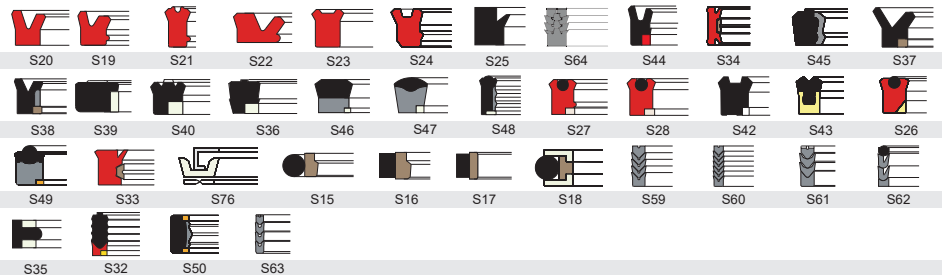

## Pneumatic Seals - Rod Seals



## Pneumatic Cushion Seals

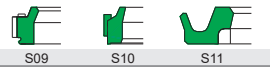

## Hydraulic Seals - Piston / Rod Seals

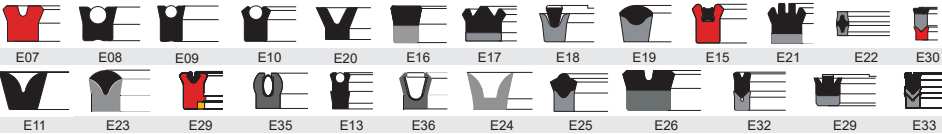

## Pneumatic Seals - Piston / Rod Seals



Other profiles are also offered for this segment.

Please refer to Max Spare product literature or Hydraulic Seals catalogue or visit our website: [www.maxspare.com](http://www.maxspare.com)

**Hydraulic & Pneumatic Seals - Wiper Seals**

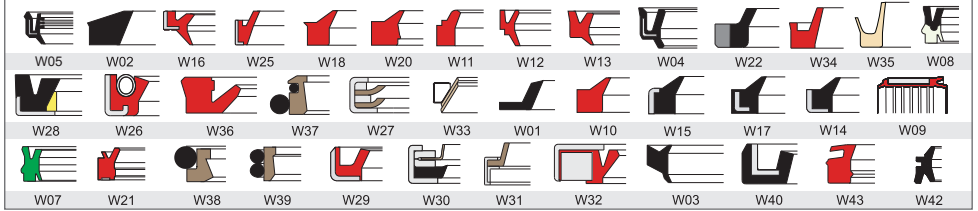

**O-Ring & Backup Ring**

**Bonded Seals**

**Guide Rings**

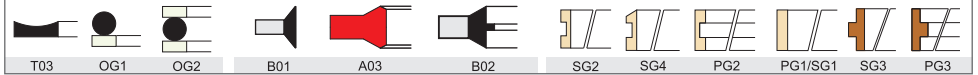

**Rotary Shaft Seals - Standard Seals**

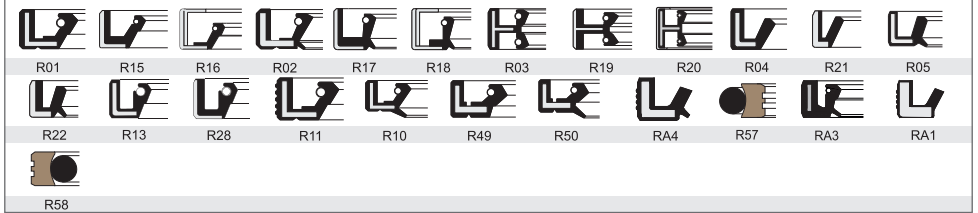

**Rotary Shaft Seals - Fabric Seals**

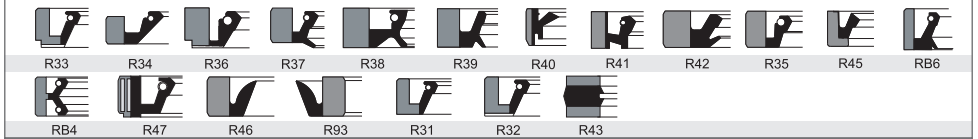

**Rotary Shaft Seals - Heavy Duty Seals**



**Rotary Shaft Seals - Special Seals**

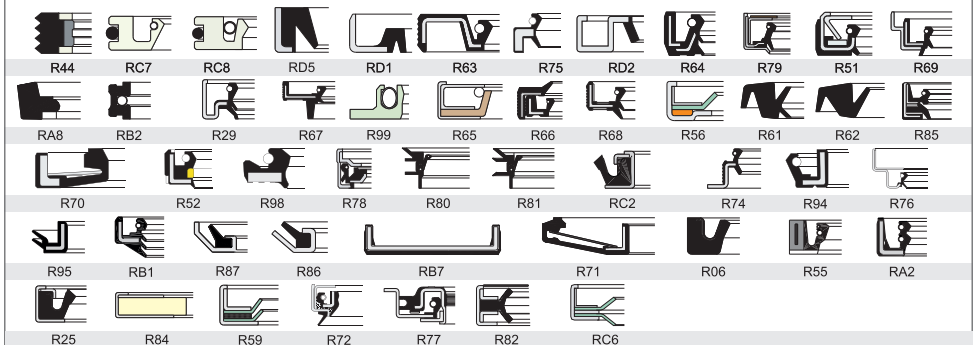

**V-rings**



### Max Express Range -

- » Seals in Non Standard Sizes      » Delivery within 4 hrs.
- » Instant online booking at [www.maxspare.com](http://www.maxspare.com)

■ 8 Hours   
 ■ 14 Hours   
 ■ 24 Hours

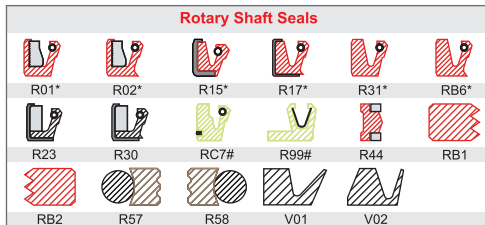
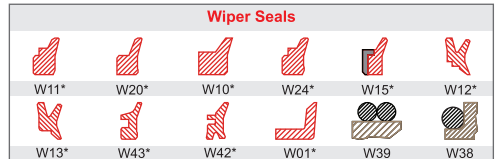
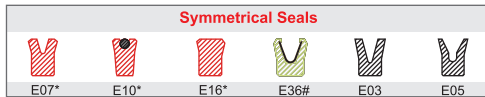
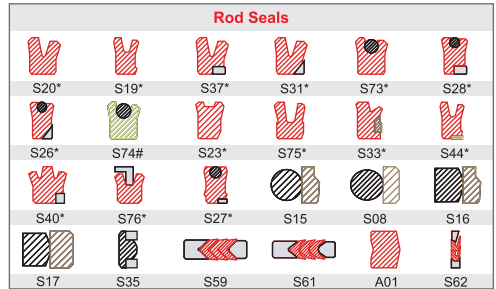
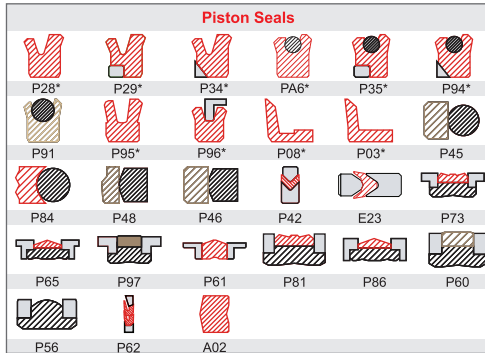

### Materials offered in Max Express Range :

Express Seals	Temp. Range
Acrylonitrile Butadiene Rubber (NBR)	-30° C to + 100° C
Polyurethane	-30° C to + 100° C
PTFE (Bronze)     PTFE (Carbon)	-250° C to + 250° C
Phenolic Resin Bonded Fabric	-20° C to + 120° C
Polyacetal (POM)	-20° C to + 80° C
Glass Filled Polyamide (Nylon) PA66	-40° C to + 150° C

- \* Available in NBR & Polyurethane Material.
- # Available in PTFE Compounds.  
(Bronze / Glass / Carbon / Graphite)
- ## Available in Phenolic Resin Bonded Fabric, Polyacetal, Cast Polyamide - PA6.

**Note:** Please mention seals style with the required material while ordering

### Delivery Schedule :

Hydraulic & Pneumatic Seals	
Size Range	Days
15 mm to 200 mm	1 Hour
201 mm to 500 mm	3 Hour
501 mm to 800 mm	12 Hour
Above 800 mm	24 Hour

Rotary Shaft Seals	
Size Range	Days
15 mm - 300 mm	Overnight (24 Hrs.)

(Excluding Courier Time)

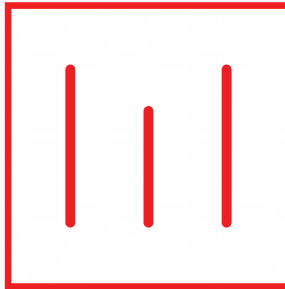

## MAX GROUP COMPANIES



### MAX SPARE LIMITED

C-44, Road No. 28, Wagle Estate,  
Thane (W) - 400604, Maharashtra, India  
T : +91-22-5028 4444 / 2222 5555  
E : sales@maxspare.com  
W : www.maxspare.com



### UNITED VAN DER HORST LIMITED

E-29/30, MIDC Taloja,  
Navi Mumbai - 410208, Maharashtra, INDIA  
T : +91 22 27412728 / 29  
E : sales@uvdhl.com  
W : www.uvdhl.com



### MAX NIRLON V-BELT

Survey No. 50, Hissa No. 1,2,3B/2B,  
Dahivali, Pali Phata, Khopoli, Tal. Khalapur,  
Dist. Raigad, Maharashtra - 410203  
T : +91-22-5028 4444  
E : sales@maxspare.com  
W : www.maxspare.com



### THE RUBBER PRODUCTS LIMITED

C-44, Road No. 28, Wagle Estate,  
Thane - 400604, Maharashtra, INDIA  
T : +91-22-5028 4444  
E : rpl@rubpro.com  
W : www.rubpro.com